

# Gas Bottles

Series GB

## IN THIS SECTION

Overview	81
Specifications	82
Models, Capacities & Dimensions	83
Sizing & Ordering Information	84



Gas  
Bottles

### Features

- Capacities from 2.5 to 50 Gallons
- High Strength Alloy Steel with Forged Ends
- Large 9" and 14" Diameter Shells
- ASME and CE Rated

Where space does not permit the installation of the required capacity accumulator, a smaller accumulator may be used by connecting it to a gas bottle(s) that can be located in a nearby spot where space is available. In some cases, an accumulator and gas bottle combination may be lower in cost, especially with large capacity applications.

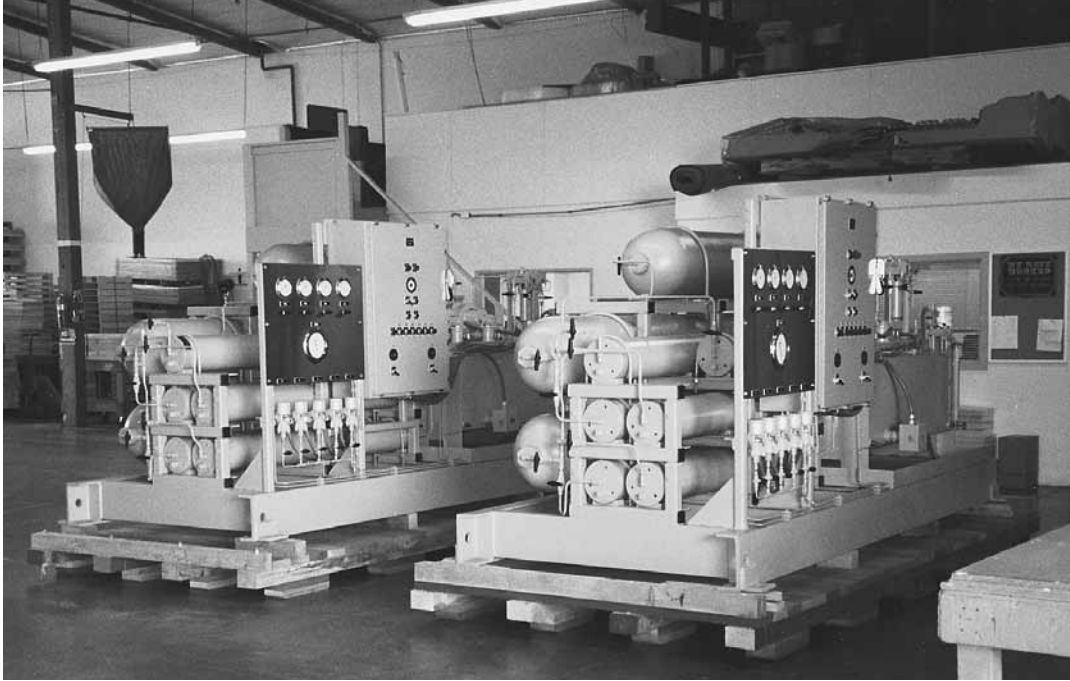

### Why Use GB Series Gas Bottles?

- reduce initial hydraulic system costs
- broad range of sizes and operating pressures
- heavy duty forged construction
- minimize plumbing with fewer large bottles
- interface well with Parker's accumulator products, especially piston accumulators
- remote location from the accumulator
- reduced precharge maintenance
- improved system backup capacities

### Parker GB Series Gas Bottles... The Right Choice!

Parker is the leading manufacturer of accumulators in North America. In addition to gas bottles, Parker's broad product line includes piston accumulators, bladder accumulators, and diaphragm accumulators. Parker's broad gas bottle offering includes:

- GB Series gas bottles (shown here)
- Piston Type Bottles (see Piston Accumulators )
- Bladder Type Bottles (see Bladder Accumulators)

## Specifications

### Materials

- Shell – high strength alloy steel, SA-372
- Ports – SAE #24 (ASME) & 2" BSPP (CE)
- SAE #5 gas valve end

**Pressure Ratings** – Parker's GB Series offers 3000 PSI, 3600 PSI and 4000 PSI ASME & 330 bar (4785 psi) CE gas bottles. See Models, Capacities and Dimensions for specific pressure ratings by size. Temperatures from -40°F to 200°F (-40°C to 93°C).

**Optional Gas Valve** – GB Series gas bottles are supplied without gas valves. See page 59 for gas valves.

**Certifications** – GB Series gas bottles are supplied as standard with ASME Section VIII Div. 1, Appendix 22 Certification. See page 6 for a complete certifications summary. CE/PED is available.

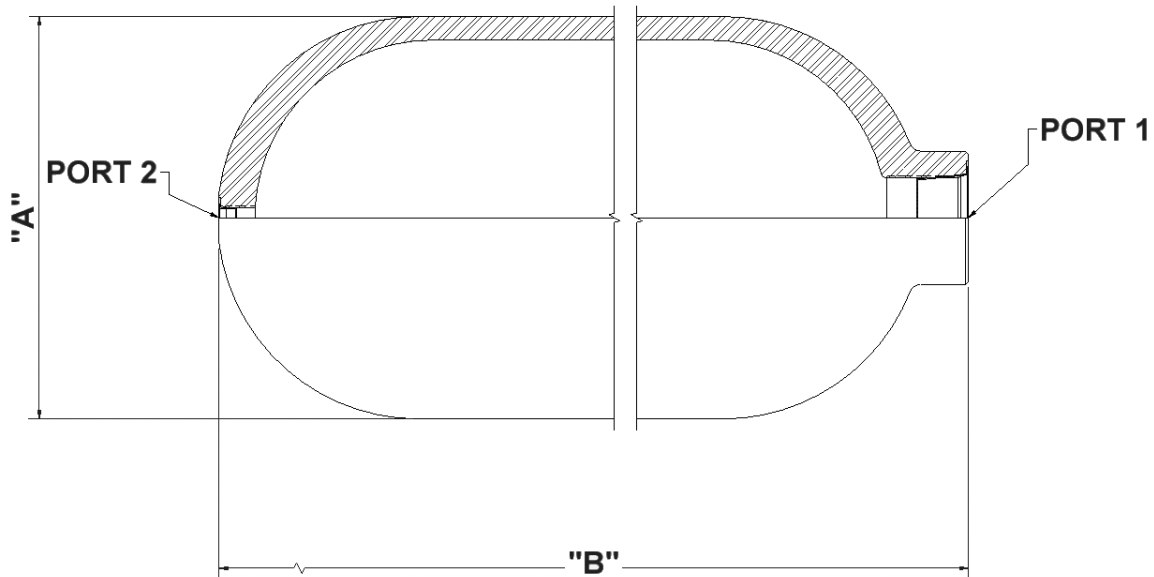

**9" OD 3000 PSI Bottles**  
 (ASME Appendix 22 = 4000 PSI)

Model #	Volume	A	B	ASME†	ASME†	CE††	CE††	Weight
9" OD Models	Gallons (liters)	inches (mm)	inches (mm)	Port 1	Port 2	Port 1	Port 2	lbs (kgs)
GB09002A30**TA1*1	2.5 (9.5)	9 (229)	17.47 (444)	SAE #24	SAE #5	2" BSPP	SAE #5	70 (32)
GB09005A30**TA2*1	5 (18.9)	9.0 (229)	29.25 (743)	SAE #24	SAE #5	2" BSPP	SAE #5	114 (52)
GB09010A30**TA2*1	10 (37.8)	9.0 (229)	52.81 (1341)	SAE #24	SAE #5	2" BSPP	SAE #5	205 (93)
GB09015A30**TA2*1	15 (56.7)	9.0 (229)	76.38 (1940)	SAE #24	SAE #5	2" BSPP	SAE #5	295 (134)
GB09020A30**TA2*1	20 (75.6)	9.0 (229)	99.94 (2539)	SAE #24	SAE #5	2" BSPP	SAE #5	386 (175)

Gas Bottles

**14" OD 3000 PSI Bottles**  
 (ASME Appendix 22 = 3600 psi)

Model #	Volume	A	B	ASME†	ASME†	CE††	CE††	Weight
14" OD Models	Gallons (liters)	inches (mm)	inches (mm)	Port 1	Port 2	Port 1	Port 2	lbs (kgs)
GB14026A30**TA2*1	26.4 (100)	13.8 (351)	59.94 (1523)	SAE #24	SAE #5	2" BSPP	SAE #5	493 (224)
GB14032A30**TA2*1	31.7 (120)	13.8 (351)	70.21 (1783)	SAE #24	SAE #5	2" BSPP	SAE #5	574 (260)
GB14040A30**TA2*1	39.6 (150)	13.8 (351)	85.52 (2172)	SAE #24	SAE #5	2" BSPP	SAE #5	693 (314)
GB14048A30**TA2*1	47.6 (180)	13.8 (351)	101 (2566)	SAE #24	SAE #5	2" BSPP	SAE #5	814 (369)
GB14053A30**TA2*1	52.8 (200)	13.8 (351)	111 (2820)	SAE #24	SAE #5	2" BSPP	SAE #5	893 (405)

† Model code changes to indicate ASME Appendix 22 design, however all dimensional data is the same.

†† Model code changes to indicate CE 330 bar design, however all dimensional data is the same.

Gas valves, brackets, charging and gauging assemblies and other accessories are sold separately.

**Gas Bottle and Accumulator Sizing Information**

When hydro-pneumatic accumulators are sized, a required accumulator capacity or volume is calculated. This calculated capacity is the total “gas” volume required to discharge a specified amount of fluid at a given pressure differential and temperature. When selecting an accumulator(s) to satisfy the requirement, two different choices are possible:

- A single accumulator with the required gas capacity.
- A single smaller accumulator with gas bottle(s) with the required total combined gas capacity.

Though all three of the above choices have their advantages, for large capacity applications the single smaller accumulator with gas bottle(s) usually proves to be the most cost effective. When sizing an accumulator with gas bottle(s) system, care must be taken when selecting the accumulator to insure that the piston does not bottom out on the end caps when being charged with or when discharging fluid. As a rule of thumb, size the accumulator with 20% to 25% greater capacity than the volume of fluid being discharged during operation. When selecting a gas bottle(s), make your selection such that the bottle(s) capacity plus the accumulator gas capacity will equal the total gas capacity required.

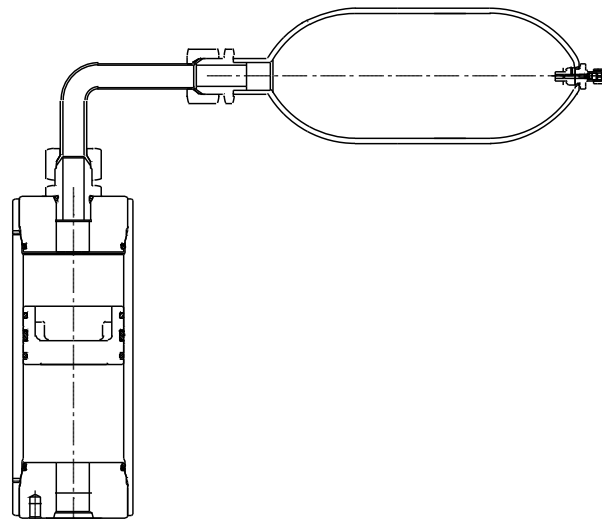

**Example:**

You calculated that you need an accumulator with an 40 gallon gas capacity. You know that 16 gallons of fluid will be discharged during operation. The proper selection would be a 20 gallon accumulator with a 20 gallon gas bottle.

**Calculation:**  
 16 gallons + 25% = 20 gallons  
 40 gallons - 20 gallons = 20 gallons.

**How to Order Gas Bottles**

GB Series gas bottles can be specified by using the symbols in the chart below to develop a model number. Select only those symbols that represent the features desired, and place them in the sequence indicated by the example at the top of the chart.

