

General Description

Series D1V directional control valve subplates provide easy transition from NFPA and CETOP mounting patterns to common plumbing connections. Five different thread types are available for use in any application.

Manifolds provide a single location to mount several valves in a compact and manageable array for operating multiple machines or functions.

C

Features

- **Aluminum or steel available** — Flexibility for applying to different system pressures.
- **NPT and SAE thread options available** — Flexibility to plumb into existing systems.
- **Multiple port sizes available** — Eliminates need for reducers and expanders at subplate connection.

Side Ported Subplate — NFPA D03

Inch equivalents for millimeter dimensions are shown in (**)

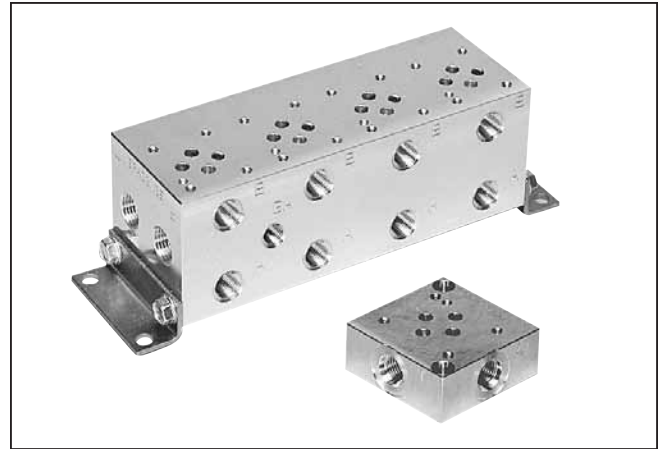
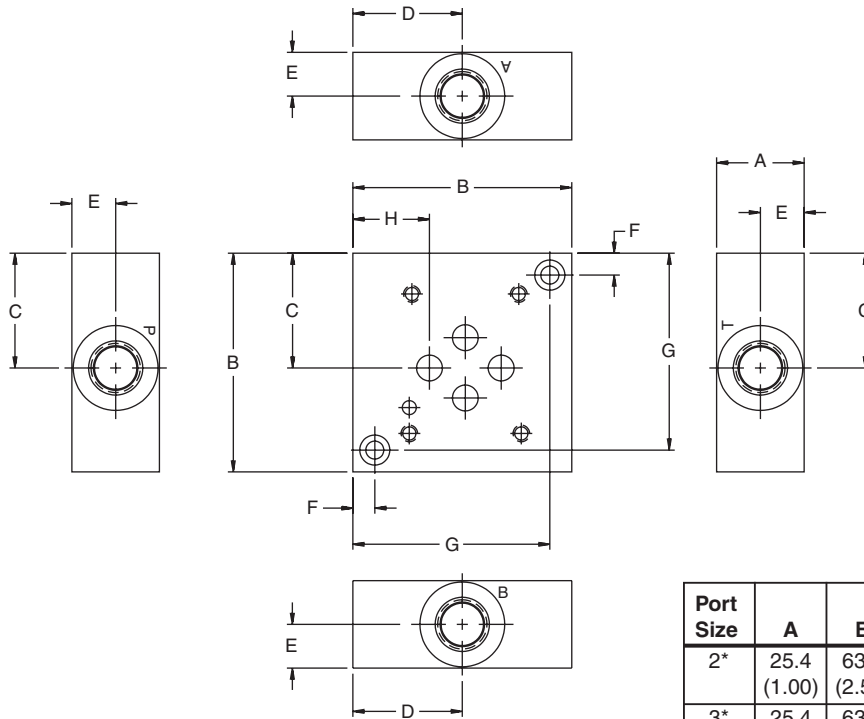

Operation

Series D1V subplates and manifolds consist of an NFPA valve mounting surface and corresponding connections for each valve port. Various port sizes and thread type are available. Cover plates, crossover and tapping plates are also available.

Port Size	A	B	C	D	E	F	G	H
2*	25.4 (1.00)	63.5 (2.50)	33.3 (1.31)	31.8 (1.25)	12.7 (.50)	6.4 (.25)	57.2 (2.25)	22.4 (.88)
3*	25.4 (1.00)	63.5 (2.50)	33.3 (1.31)	31.8 (1.25)	12.7 (.50)	6.4 (.25)	57.2 (2.25)	22.4 (.88)
4*	38 (1.50)	88.9 (3.50)	46.0 (1.81)	45.2 (1.78)	19.1 (.75)	6.4 (.25)	82.5 (3.25)	35.1 (1.38)
6*	44.5 (1.75)	101.6 (4.00)	52.3 (2.06)	51.6 (2.03)	22.4 (.88)	9.7 (.38)	92.2 (3.63)	41.4 (1.63)

See Mounting Bolt Kits for bolt information.

Series D1V

Bottom Ported Subplate — NFPA D03

Inch equivalents for millimeter dimensions are shown in (**)

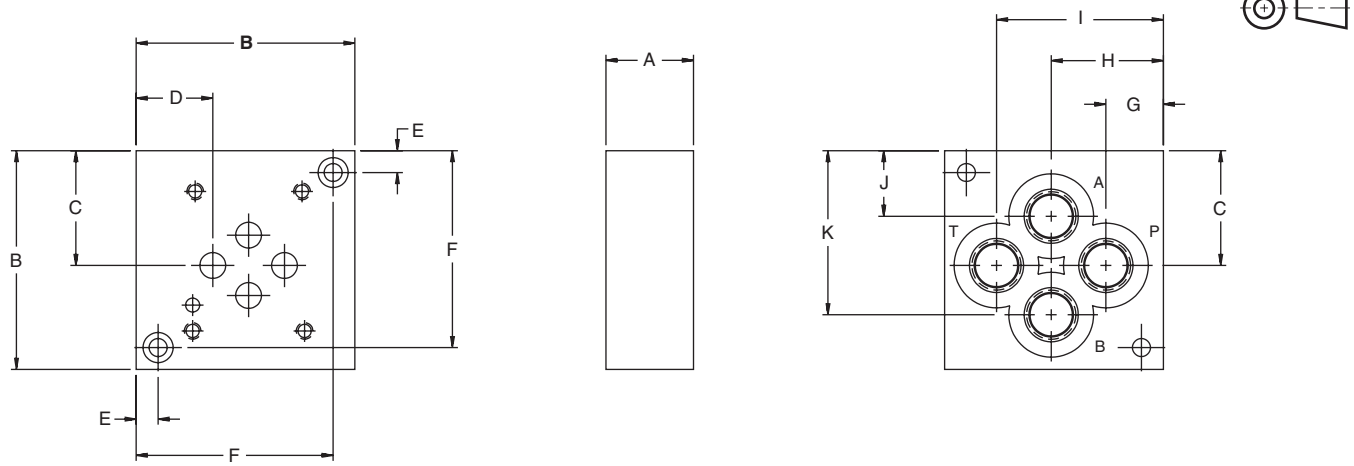

Port Size	A	B	C	D	E	F	G	H	I	J	K
2*	25.4 (1.00)	63.5 (2.50)	33.3 (1.31)	22.4 (.88)	6.4 (.25)	57.2 (2.25)	16.8 (.66)	32.5 (1.28)	48.5 (1.91)	19.1 (.75)	47.8 (1.88)
3*	25.4 (1.00)	63.5 (2.50)	33.3 (1.31)	22.4 (.88)	6.4 (.25)	57.2 (2.25)	15.0 (.59)	32.5 (1.28)	50.0 (1.97)	17.5 (.69)	49.3 (1.94)
4*	38.1 (1.50)	88.9 (3.50)	46.0 (1.81)	35.1 (1.38)	6.4 (.25)	82.6 (3.25)	17.5 (.69)	45.2 (1.78)	71.4 (2.81)	19.1 (.75)	71.4 (2.81)
6*	38.1 (1.50)	114.3 (4.50)	58.7 (2.31)	47.8 (1.88)	9.7 (.38)	104.9 (4.13)	23.9 (.94)	57.9 (2.28)	90.4 (3.56)	23.9 (.94)	90.4 (3.56)

See Mounting Bolt Kits for bolt information.



Series D1V
Manifold — NFPA D03

Inch equivalents for millimeter dimensions are shown in (**)

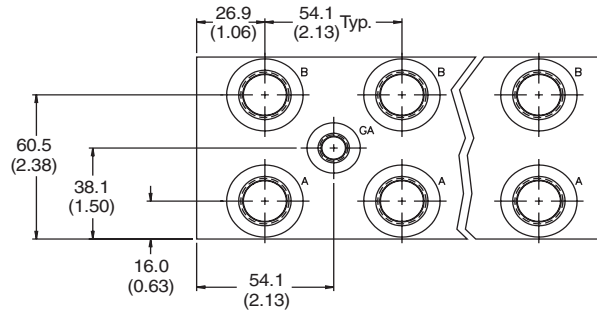
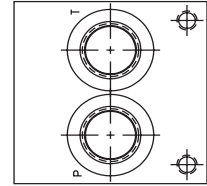
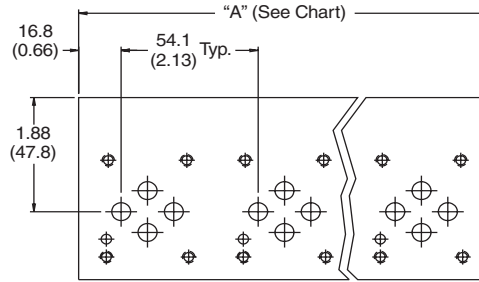
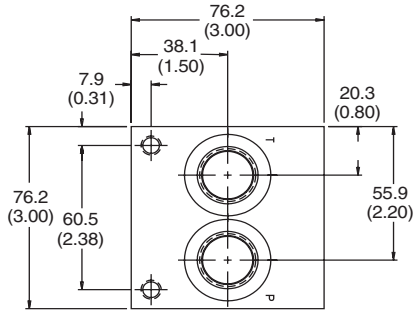

Note: Gage port not available on single station manifold.

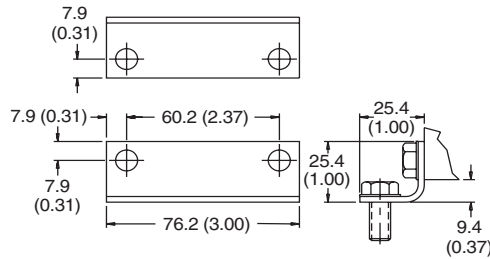

Mounting Hardware
 (See Ordering Information for Mounting Hardware details)

No. Stations	1	2	3	4	5	6	7	8
"A" Length mm (inch)	54.1 (2.13)	108.0 (4.25)	162.1 (6.38)	215.9 (8.50)	270.0 (10.63)	323.9 (12.75)	378.0 (14.88)	431.8 (17.00)
Wgt., Alum, kg (lbs.)	1.4 (3)	1.8 (4)	2.7 (6)	3.6 (8)	4.1 (9)	5.0 (11)	5.4 (12)	6.4 (14)
Wgt., Iron, kg (lbs.)	2.3 (5)	4.1 (9)	5.9 (13)	7.7 (17)	9.5 (21)	11.8 (26)	13.6 (30)	15.4 (34)

See Mounting Bolt Kits for bolt information.

Series D1V Subplates

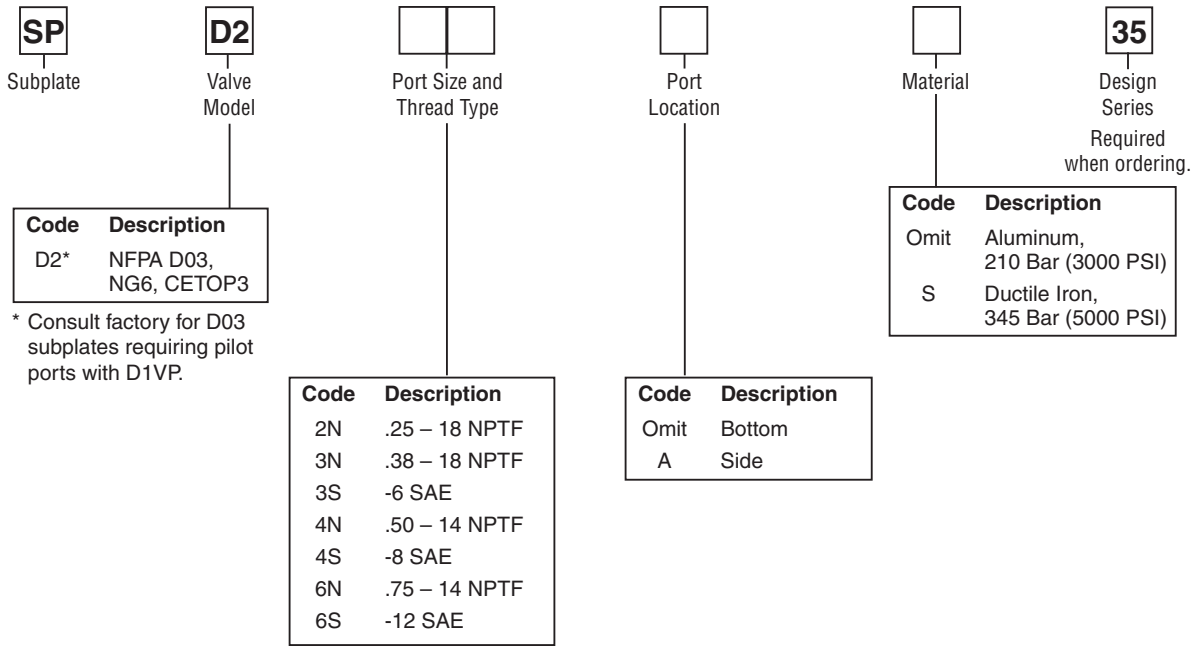

Note: 35 Design Series subplates conform to NFPA mounting pattern specifications, but may be dimensionally different from previous design series.

Mounting Bolt Kits

UNC Bolt Kits for use with D1V Directional Control Valves & Sandwich Valves (D1V*-91 Design, Solenoid Operated)					
	Number of Sandwich Valves @ 1.58" (40mm) thickness				
	0	1	2	3	4
D1V-91	BK209 1.25"	BK243 2.88"	BK225 4.38"	BK244 6.00"	BK245 7.50"
D1V-91 Plus Tapping Plate	BK176 2.25"	BK56 3.81"	BK212 5.38"	BK107 7.00"	BK106 8.50"

Note: All bolts are SAE grade 8, 10-24 UNC-2A thread, torque to 5.6 N.m. (50 in.-lbs.)

Mounting Hardware
 supplied with subplate includes:

Subplates	Mounting Hardware	Qty.
SPD22N**	.25-20 UNC x	2
SPD23N**	.88 LG. SHCS	
SPD23S**		
SPD24N**	.25-20 UNC x	2
SPD24S**	1.5 LG. SHCS	
SPD26N*	.38-16 UNC x	2
SPD26S*	1.50 LG. SHCS	
SPD26NA*	.38-16 UNC x	2
SPD26SA*	1.75 LG. SHCS	

Valve mounting threads:
 #10-24 UNC x 0.63 DP.
 Used for SAE and NPTF ports.
 Metric M5-0.8mm ISO 6H x 16 DP.
 Used for BSPP, BSPT and ISO ports.



Series D1V Manifolds

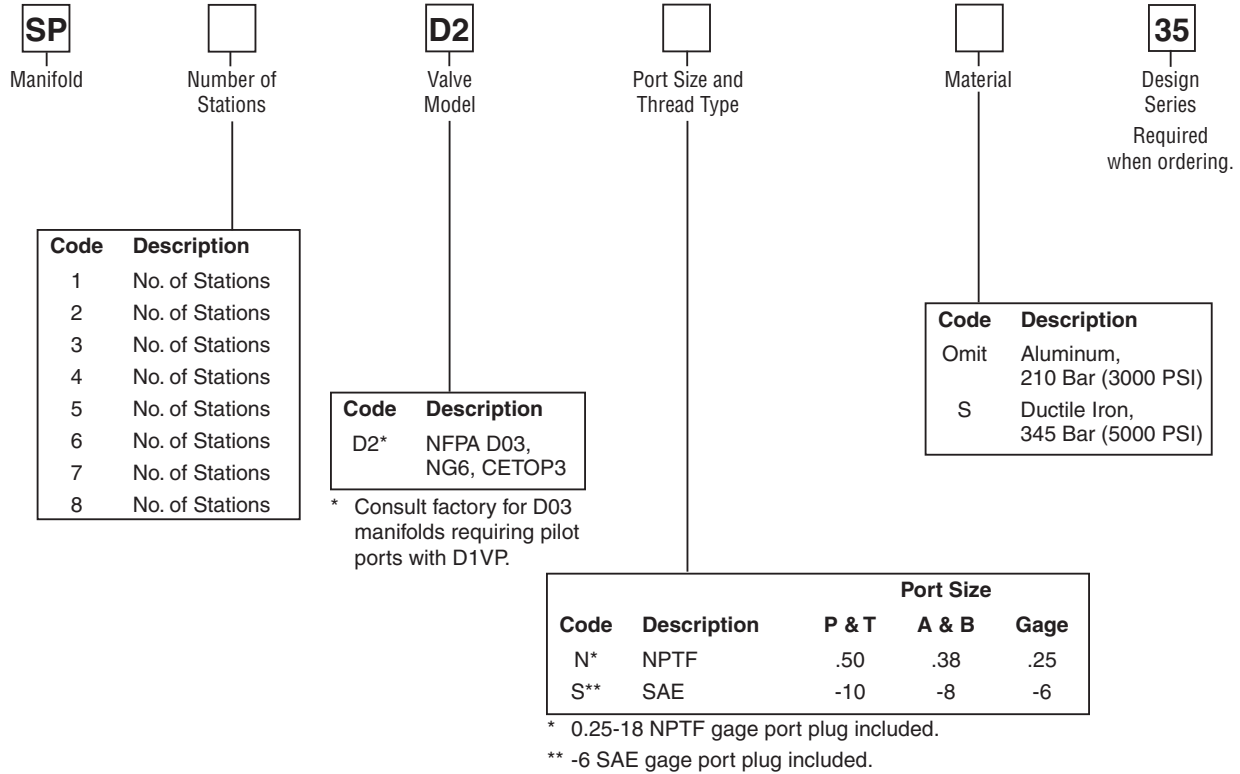

Note: 35 Design Series manifolds conform to NFPA mounting pattern specifications, but may be dimensionally different from previous design series.

Mounting Bolt Kits

UNC Bolt Kits for use with D1V Directional Control Valves & Sandwich (D1V*-91 Design, Solenoid Operated)					
	Number of Sandwich @ 1.58" (40mm) thickness				
	0	1	2	3	4
D1V-91	BK209 1.25"	BK243 2.88"	BK225 4.38"	BK244 6.00"	BK245 7.50"
D1V-91 Plus Tapping Plate	BK176 2.25"	BK56 3.81"	BK212 5.38"	BK107 7.00"	BK106 8.50"

Mounting hardware supplied with manifold includes:
 (2) steel brackets
 For SAE and NPTF ports: (8) 5/16-18 UNC x .63 hex washer cap screws.
 Valve mounting threads:
 #10-24 UNC x 0.63 DP. Used for SAE and NPTF ports.

Note: All bolts are SAE grade 8, 10-24 UNC-2A thread, torque to 5.6 N.m. (50 in.-lbs.)

No. Stations	1	2	3	4	5	6	7	8
Wgt., Alum, kg (lbs.)	1.4 (3)	1.8 (4)	2.7 (6)	3.6 (8)	4.1 (9)	5.0 (11)	5.4 (12)	6.4 (14)
Wgt., Iron, kg (lbs.)	2.3 (5)	4.1 (9)	5.9 (13)	7.7 (17)	9.5 (21)	11.8 (26)	13.6 (30)	15.4 (34)

Features

- **Aluminum or steel available** — Flexibility for applying to different system pressures.
- **NPT and SAE thread options available** — Flexibility to plumb into existing systems.
- **Multiple port sizes available** — Eliminates need for reducers and expander at subplate connection.

Side Ported Subplate — NFPA D05

Inch equivalents for millimeter dimensions are shown in (**)

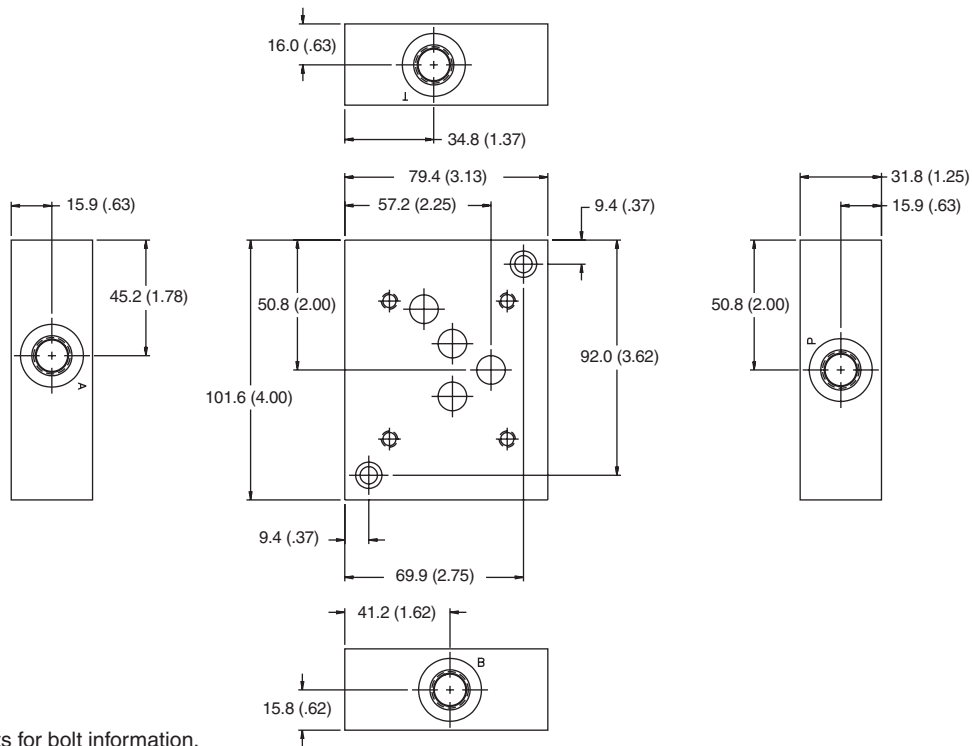
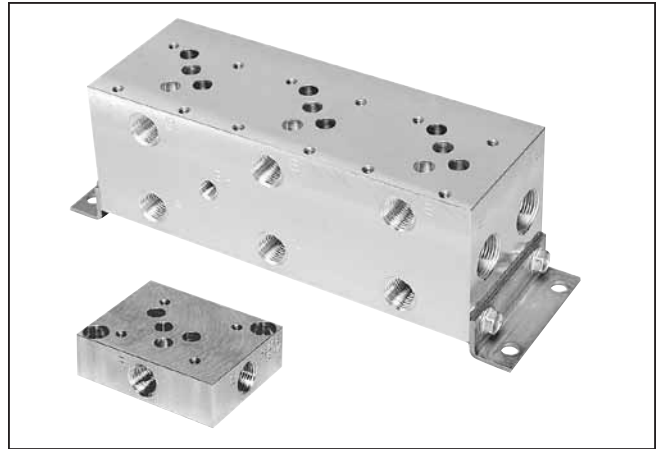

See Mounting Bolt Kits for bolt information.



Bottom Ported Subplate — NFPA D05

Inch equivalents for millimeter dimensions are shown in (**)

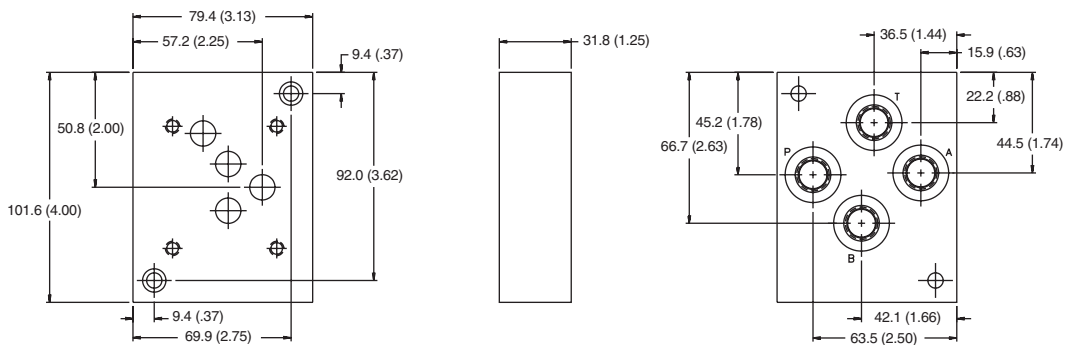

See Mounting Bolt Kits for bolt information.

Subplate-Manifold.indd, dd

Series D3A, D3DW, D3L and D3W

Manifold — NFPA D05

Inch equivalents for millimeter dimensions are shown in (**)

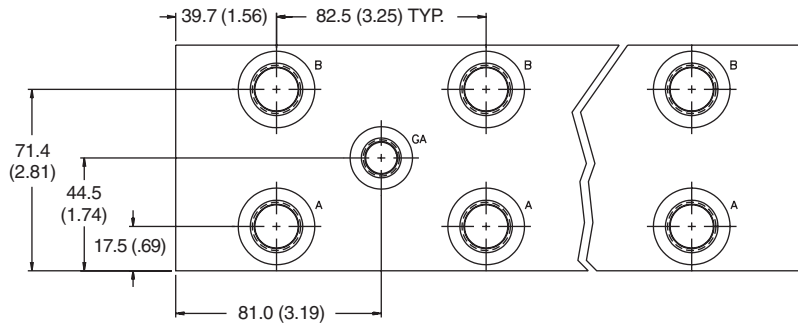
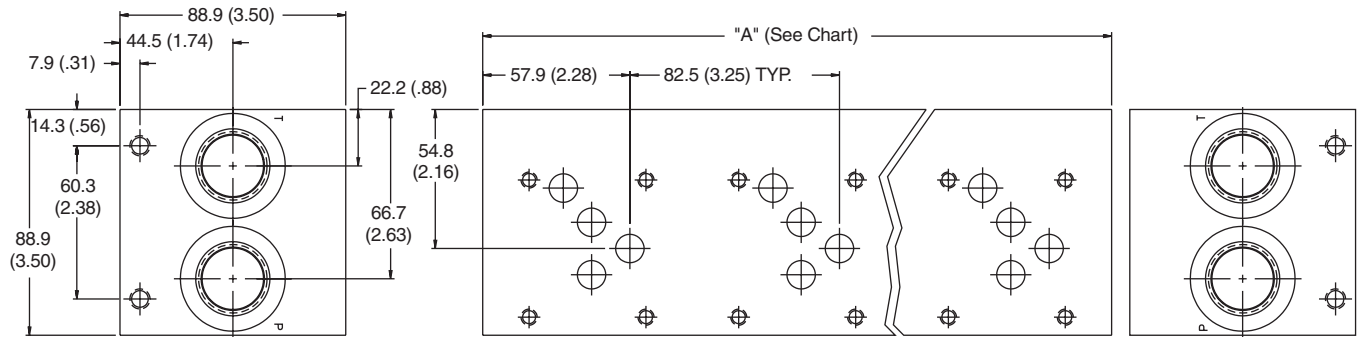

Note: Gage port not available on single station manifold.

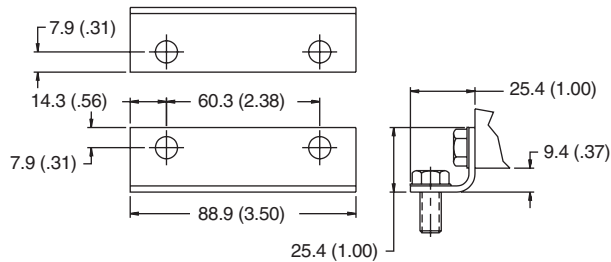

Mounting Hardware
(See Ordering Information for Mounting Hardware details)

No. Stations	1	2	3	4	5	6
"A" Length, mm (in)	82.6 (3.25)	165.1 (6.50)	247.7 (9.75)	330.2 (13.00)	412.8 (16.25)	495.3 (19.50)
Weight, Alum. kg (lbs.)	1.8 (4)	3.6 (8)	5.0 (11)	6.4 (14)	7.9 (17)	9.6 (21)
Weight, Iron kg (lbs.)	4.1 (9)	7.7 (17)	11.8 (26)	15.4 (34)	20.1 (43)	23.3 (51)

See Mounting Bolt Kits for bolt information.

Features

- **Aluminum or steel available** — Flexibility for applying to different system pressures.
- **NPT and SAE thread options available** — Flexibility to plumb into existing systems.
- **Multiple port sizes available** — Eliminates need for reducers and expander at subplate connection.
- **Parallel or series circuit applications** — Flexibility for different circuits.

Side Ported Subplate — NFPA D05, D05H and D05HE

Inch equivalents for millimeter dimensions are shown in (**)

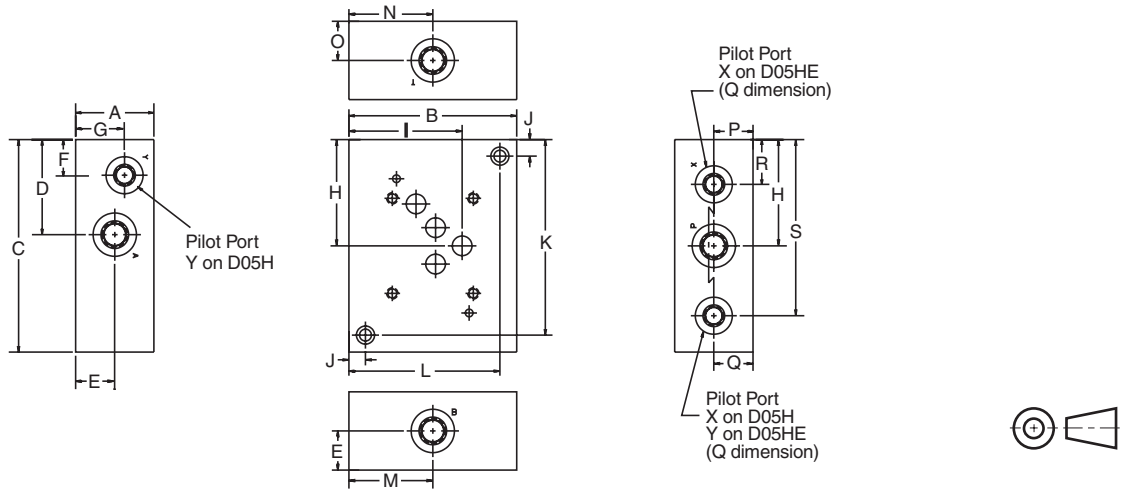
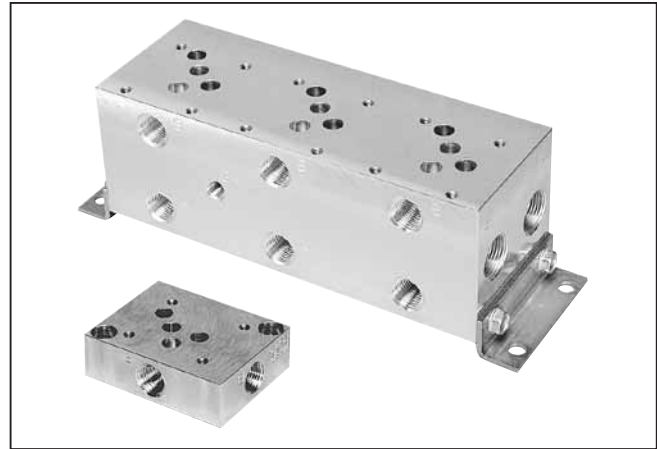

Dimensions	A	B	C	D	E	F*	G*	H	I	J	K	L	M	N	O	P	Q*	R*	S*
SPD31V**A*	44.5 (1.75)	95.3 (3.75)	120.7 (4.75)	54.1 (2.13)	22.4 (0.88)	20.6 (0.81)	22.4 (0.88)	60.2 (2.37)	64.3 (2.53)	9.7 (0.38)	111.0 (4.37)	85.9 (3.38)	47.8 (1.88)	47.8 (1.88)	22.4 (0.88)	22.4 (0.88)	22.4 (0.88)	—	100.1 (3.94)
SPD31D**A*	44.5 (1.75)	95.3 (3.75)	120.7 (4.75)	54.1 (2.13)	22.4 (0.88)	—	—	60.2 (2.37)	64.3 (2.53)	9.7 (0.38)	111.0 (4.37)	85.9 (3.38)	47.8 (1.88)	47.8 (1.88)	22.4 (0.88)	22.4 (0.88)	11.2 (0.44)	25.4 (1.00)	100.1 (3.94)

See Mounting Bolt Kits for bolt information.

* Not available with high flow option.

Bottom Ported Subplate — NFPA D05, D05H and D05HE

Inch equivalents for millimeter dimensions are shown in (**)

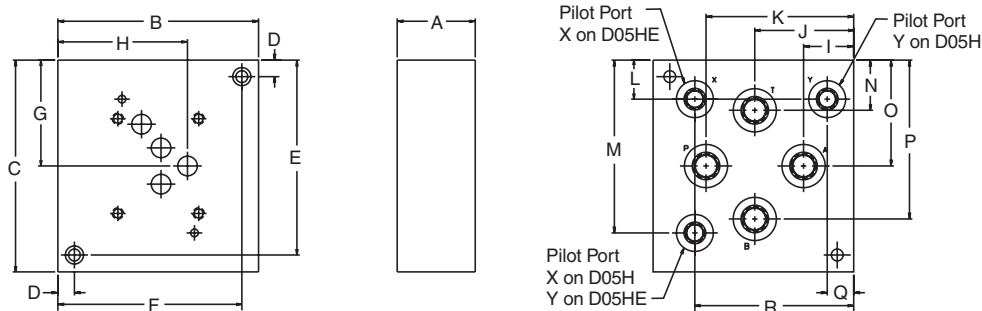

Dimension	A	B	C	D	E	F	G	H	I	J	K	L*	M*	N	O	P	Q*	R*
SPD31V***	44.5 (1.75)	114.3 (4.50)	120.7 (4.75)	9.7 (0.38)	111.3 (4.38)	104.9 (4.13)	60.2 (2.37)	73.9 (2.91)	28.4 (1.12)	56.4 (2.22)	84.1 (3.31)	22.4 (0.88)	98.6 (3.88)	28.7 (1.13)	60.5 (2.38)	90.4 (3.56)	15.0 (0.59)	90.4 (3.56)
SPD31D***	44.5 (1.75)	114.3 (4.50)	120.7 (4.75)	9.7 (0.38)	111.3 (4.38)	104.9 (4.13)	60.2 (2.37)	73.9 (2.91)	28.4 (1.12)	56.4 (2.22)	84.1 (3.31)	20.6 (0.81)	100.1 (3.94)	28.7 (1.13)	60.5 (2.38)	90.4 (3.56)	—	88.9 (3.50)

See Mounting Bolt Kits for bolt information.

* Not available with high flow option.

Subplate-Manifold.indd, dd

Series D3P and High Flow

Manifold — NFPA D05, D05H and D05HE

Inch equivalents for millimeter dimensions are shown in (**)

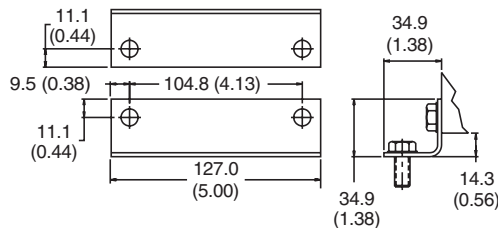
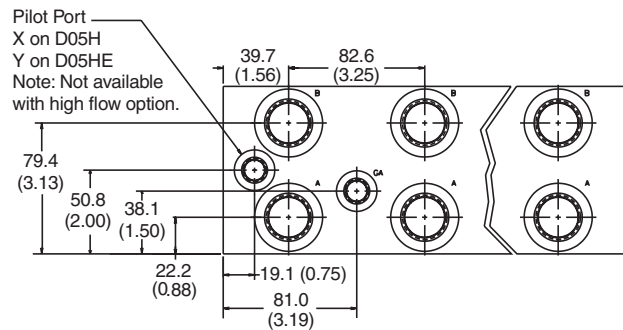
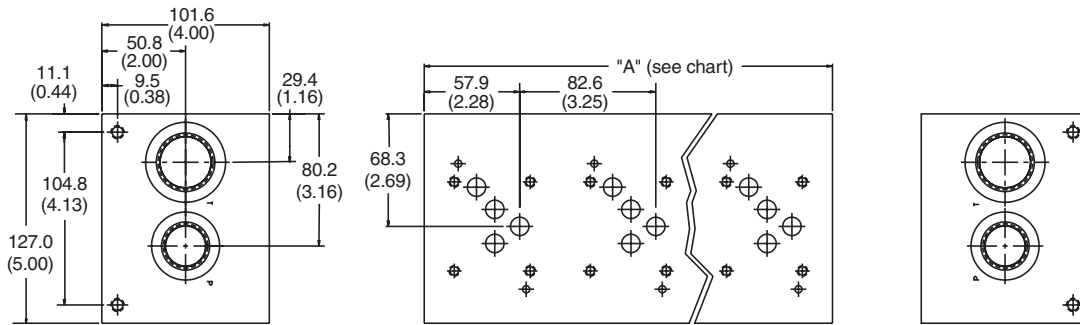
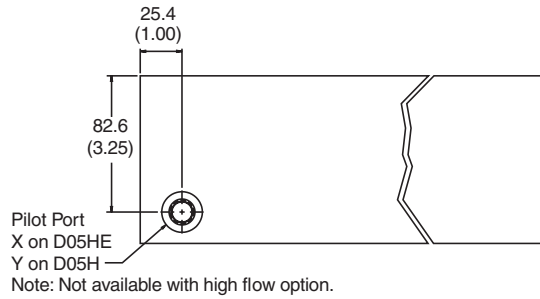

Mounting Hardware
(See Ordering Information for Mounting Hardware details)

No. of Stations	1	2	3	4	5	6
"A" Length mm (inch)	82.6 (3.25)	165.1 (6.50)	247.7 (9.75)	330.2 (13.00)	412.8 (16.25)	495.3 (19.50)
Weight Alum. kg (lbs.)	15.4 (7.00)	26.5 (12.00)	37.5 (17.00)	48.5 (22.00)	59.5 (27.00)	72.8 (33.00)
Weight Iron kg (lbs.)	41.9 (19.00)	83.8 (38.00)	125.7 (57.00)	165.4 (75.00)	187.4 (85.00)	249.2 (113.00)

See Mounting Bolt Kits for bolt information.

Series D3 and D31 Subplates

SP
 Subplate

Valve Model

Port Size and Thread Type

Port Location

Material

35
 Design Series
 Required when ordering.

Code	Description
D3	NFPA D05, CETOP5
D31V	NFPA D05H
D31D	NFPA D05HE, NG10, CETPOP5H

D31 manifolds come standard with high flow capability. For flows over 20 GPM use D31V or D31D subplate. It will have X and Y ports.

Code	Description
Omit	Aluminum, 210 Bar (3000 PSI)
S	Ductile Iron, 345 Bar (5000 PSI)

Code	Description
Omit	Bottom
A	Side

Code	Description
# 3N	.38 – 18 NPTF
# 4N	.50 – 14 NPTF
# 4S	-8 SAE
* 6N	.75 – 14 NPTF
* 6S	-12 SAE

Sizes 3* and 4* ports available on SPD3 (NFPA D05) only.
 * Size 6* port available on SPD31 (NFPA D05H and D05HE) only.

Mounting Hardware
 supplied with subplate includes:

Subplates	Mounting Hardware	Qty.
SPD33N**	.38-16 UNC x	2
SPD34N**	1.25 LG. SHCS	
SPD34S**		
SPD31*6N**	.38-16 UNC x	2
SPD31*6S**	1.75 LG. SHCS	
SPD3H6N**		
SPD3H6S**		

Valve mounting threads:
 0.25-20 UNC x 0.75 DP.
 Used for SAE and NPTF ports.

Note: 35 Design Series subplates conform to NFPA mounting pattern specifications, but may be dimensionally different from previous design series.

Subplate-Manifold.indd, dd

Mounting Bolt Kits

UNC Bolt Kits for use with D3W, D3, D31VW, D31DW Directional Control Valves & Sandwich Valves				
	Number of Sandwich Valves @2.00" (50mm) thickness			
	0	1	2	3
D3-32, D31VW-91, D31DW-91, D3P	BK98 1.625"	BK141 3.50"	BK142 5.50"	BK143 7.50"
D3-32, D31VW-91, D31DW-91, D3P plus tapping plate	BK166 2.50"	BK167 4.50"	BK168 6.50"	BK169 8.50"

Note: All bolts are SAE grade 8, 1/4-20 UNC-2A thread, torque to 16 N.m. (12 ft.-lbs.)



Series D3 Manifolds

SP

Manifold

Number of Stations

D3

Valve Model

Flow Option

Port Size and Thread Type

Material

35

Design Series
 Required when ordering.

Code	Description
1	No. of Stations
2	No. of Stations
3	No. of Stations
4	No. of Stations
5	No. of Stations
6	No. of Stations

Code	Description
D3	NFPA D05, NG10, CETOP5

Code	Description
Omit	Standard Less than 76 LPM (20 GPM)
H*	High Flow Greater than 76 LPM (20 GPM)

*Only available with D3 (D05) model

Code	Description
Omit	Aluminum, 210 Bar (3000 PSI)
S	Ductile Iron, 345 Bar (5000 PSI)

Code	Description	Port Size		
		P & T	A & B	Gage
N*	NPTF	.75	.50	.25
S**	SAE	-12	-8	-6

* 0.25-18 NPTF gage port plug included.

** -6 SAE gage port plug included.

Mounting hardware supplied with manifold includes:

(2) steel brackets

For SAE and NPTF ports:

(8) 5/16-18 UNC x .63 hex washer cap screws

Valve mounting threads:

0.25-20 UNC x 0.75 DP.

Used for SAE and NPTF ports.

Note: 35 Design Series manifolds conform to NFPA mounting pattern specifications, but may be dimensionally different from previous design series.

No. Stations	1	2	3	4	5	6
Wgt., Alum, kg (lbs.)	1.8 (4)	3.7 (8)	5.0 (11)	6.4 (14)	7.8 (17)	9.6 (21)
Wgt., Iron, kg (lbs.)	4.1 (9)	7.8 (17)	11.9 (26)	15.6 (34)	19.7 (43)	23.3 (51)

Mounting Bolt Kits

UNC Bolt Kits for use with D3W and D3 Directional Control Valves & Sandwich Valves				
	Number of Sandwich Valves @2.00" (50mm) thickness			
	0	1	2	3
D3-32	BK98 1.625"	BK141 3.50"	BK142 5.50"	BK143 7.50"
D3-32 plus tapping plate	BK166 2.50"	BK167 4.50"	BK168 6.50"	BK169 8.50"

Note: All bolts are SAE grade 8, 1/4-20 UNC-2A thread, torque to 16 N.m. (12 ft.-lbs.)

Series D31 and D3P Manifolds

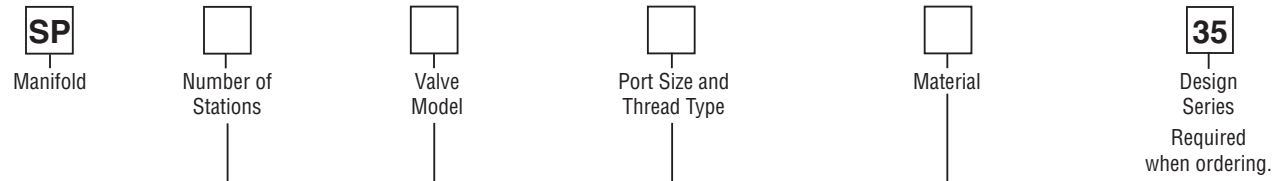

Code	Description
1	No. of Stations
2	No. of Stations
3	No. of Stations
4	No. of Stations
5	No. of Stations
6	No. of Stations

Code	Description
D31V	NFPA D05H, D3P
D31D	NFPA D05HE, NG10, CETOP5H

D31 manifolds come standard with high flow capability.

Code	Description
Omit	Aluminum, 210 Bar (3000 PSI)
S	Ductile Iron, 345 Bar (5000 PSI)

Code	Description	Port Size			
		P, A, B	T	X, Y	Gage
N*	NPTF	.75	1.00	.38	.25
S**	SAE	-12	-16	-6	-6

* 0.25-18 NPTF gage port plug included.

** -6 SAE gage port plug included.

Mounting hardware supplied with manifold includes:

- (2) steel brackets
- For SAE and NPTF ports:
- (8) 3/8-16 UNC x .88 HHCS
- and (8) .38 SAE N series washers

Valve mounting threads:
 0.25-20 UNC x 0.75 DP.
 Used for SAE and NPTF ports.

Note: 35 Design Series manifolds conform to NFPA mounting pattern specifications, but may be dimensionally different from previous design series.

No. Stations	1	2	3	4	5	6
Wgt., Alum, kg (lbs.)	3.2 (7)	5.5 (12)	7.8 (17)	10.1 (22)	12.3 (27)	15.1 (33)
Wgt., Iron, kg (lbs.)	8.7 (19)	17.4 (38)	26.1 (57)	34.3 (75)	38.9 (85)	51.7 (113)

Mounting Bolt Kits

UNC Bolt Kits for use with D3P, D31VW and D31DW Directional Control Valves & Sandwich Valves (D31V*-91 Design, Solenoid Operated)				
	Number of Sandwich Valves @ 2.00" (50mm) thickness			
	0	1	2	3
D31VW-91, D3P D31DW-91	BK98 1.625"	BK141 3.50"	BK142 5.50"	BK143 7.50"
D31VW-91, D3P D31DW-91 plus tapping plate	BK166 2.50"	BK167 4.50"	BK168 6.50"	BK169 8.50"

Note: All bolts are SAE grade 8, 1/4-20 UNC-2A thread, torque to 16 N.m. (12 ft.-lbs.)



Features

- **Aluminum or steel available** — Flexibility for applying to different system pressures.
- **NPT and SAE thread options available** — Flexibility to plumb into existing systems.
- **Multiple port sizes available** — Eliminates need for reducers and expander at subplate connection.

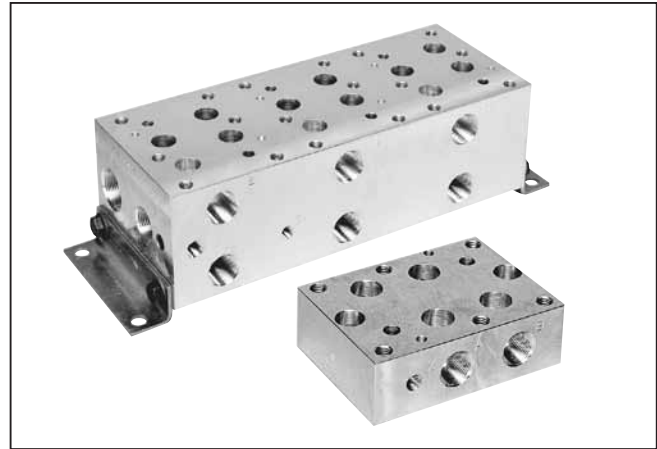

Side Ported Subplate — NFPA D08

Inch equivalents for millimeter dimensions are shown in (**)

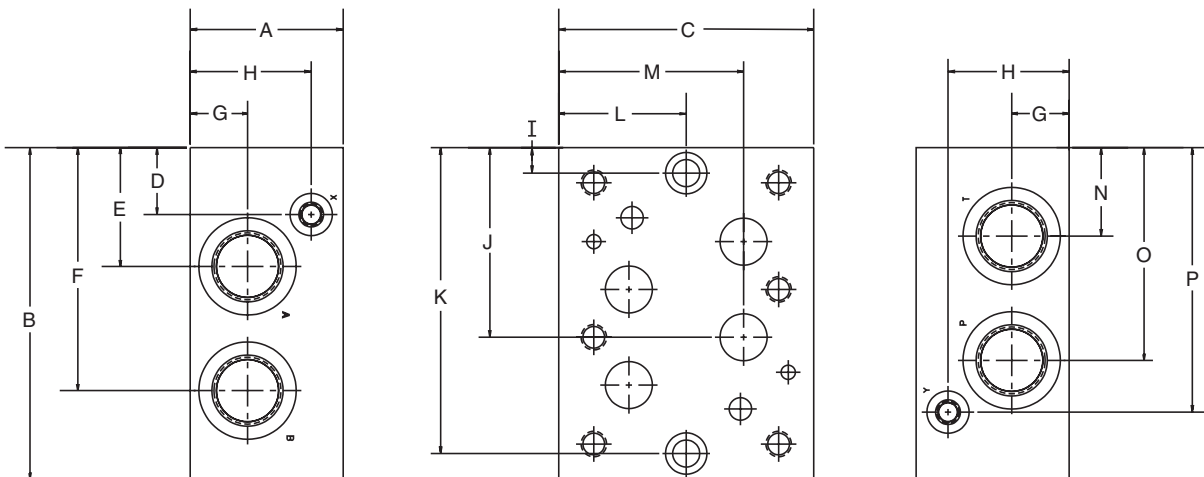

Size	A	B	C	D	E	F	G	H	I	J	K	L	M	N	O	P
SPD68*A*	50.8	155.7	114.3	30.2	64.3	115.1	25.4	25.4	12.7	89.7	142.7	57.2	85.9	40.4	91.2	125.5
SPD66NA*	(2.00)	(6.13)	(4.50)	(1.19)	(2.53)	(4.53)	(1.00)	(1.00)	(0.50)	(3.53)	(5.62)	(2.25)	(3.38)	(1.59)	(3.59)	(4.94)
SPD610*A*	76.2	165.1	127.0	33.3	59.2	121.2	28.7	60.5	12.7	94.5	152.4	63.5	92.2	43.9	105.9	131.8
	(3.00)	(6.50)	(5.00)	(1.31)	(2.33)	(4.77)	(1.13)	(2.38)	(0.50)	(3.72)	(6.00)	(2.50)	(3.63)	(1.73)	(4.17)	(5.19)

See Mounting Bolt Kits for bolt information.

Series D6 and D8
Bottom Ported Subplate — NFPA D08
 Inch equivalents for millimeter dimensions are shown in (**)

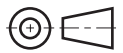
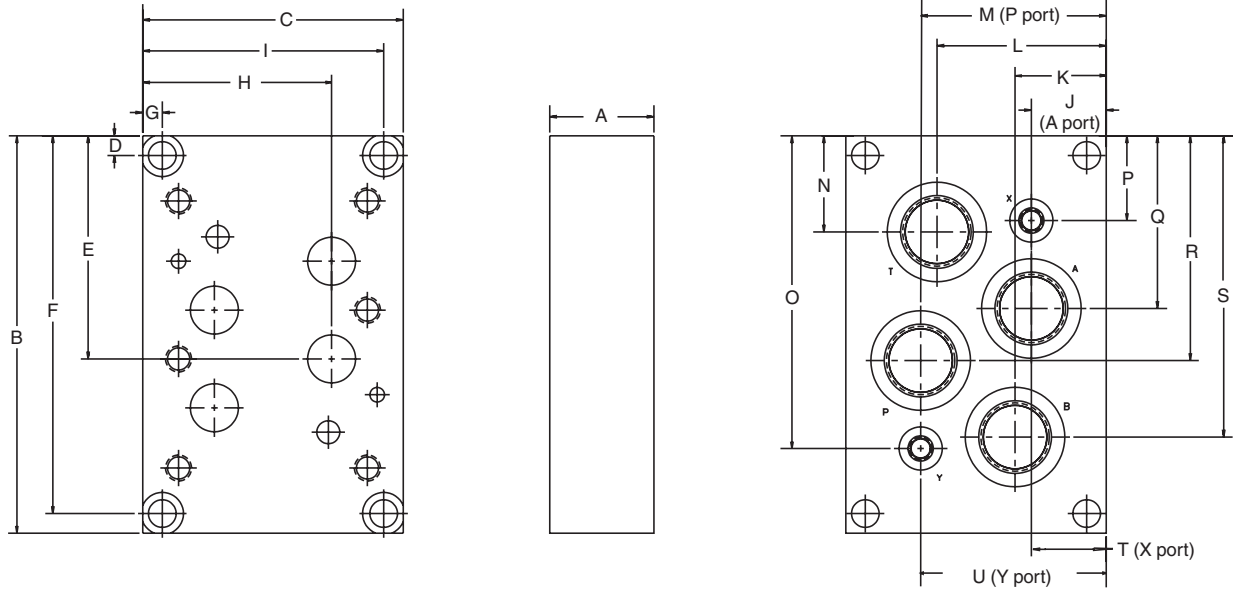

Size	A	B	C	D	E	F	G	H	I	J	K	L	M	N	O	P	Q	R	S	T	U
SPD68**	38.1	155.7	117.6	12.7	89.7	142.7	58.7	87.4	—	30.2	30.2	87.4	87.4	42.2	125.5	30.2	65.8	89.7	113.5	31.8	85.9
SPD66N*	(1.50)	(6.13)	(4.63)	(0.50)	(3.53)	(5.62)	(2.31)	(3.44)	—	(1.19)	(1.19)	(3.44)	(3.44)	(1.66)	(4.94)	(1.19)	(2.59)	(3.53)	(4.47)	(1.25)	(3.38)
SPD610**	50.8	193.8	127.0	9.7	108.7	184.2	9.7	92.2	117.6	36.6	44.5	82.6	90.4	46.7	152.4	41.4	84.1	109.5	146.8	36.6	90.4
	(2.00)	(7.63)	(5.00)	(0.38)	(4.28)	(7.25)	(0.38)	(3.63)	(4.63)	(1.44)	(1.75)	(3.25)	(3.56)	(1.84)	(6.00)	(1.63)	(3.31)	(4.31)	(5.78)	(1.44)	(3.56)

See Mounting Bolt Kits for bolt information.

Series D6 and D8
Manifold — NFPA D08

Inch equivalents for millimeter dimensions are shown in (**)

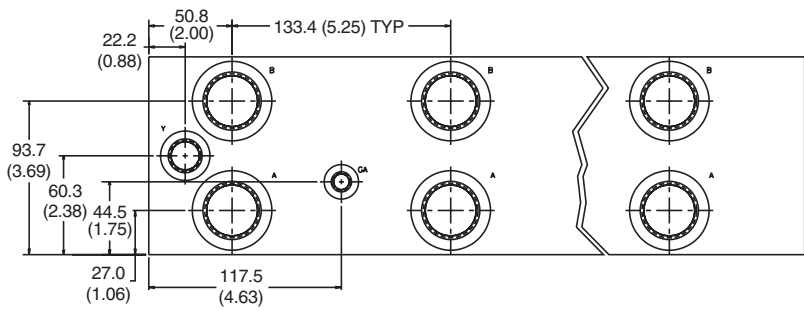
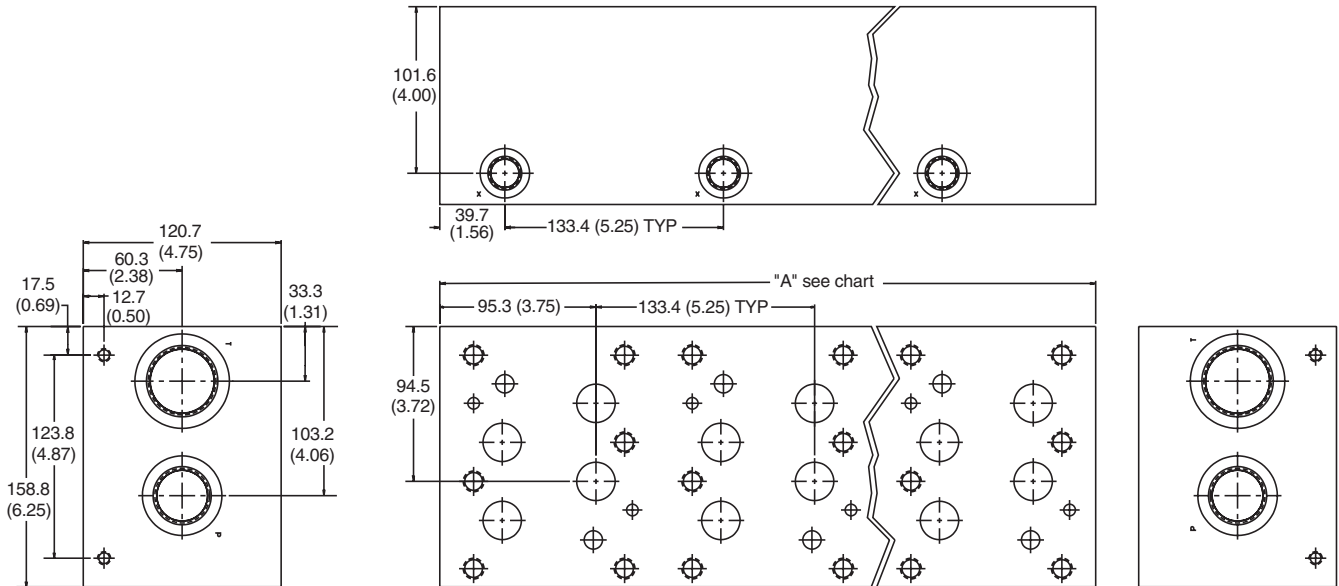

Note: Gage port not available on single station manifold.

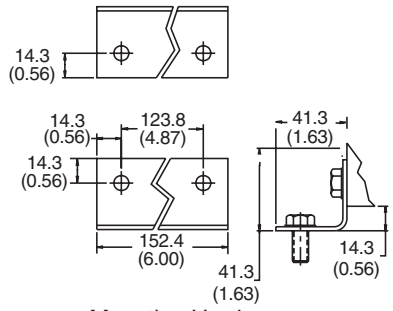
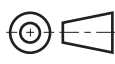

Mounting Hardware
 (See Ordering Information for Mounting Hardware details)

No. of Stations	1	2	3	4	5
"A" Length mm (inch)	133.35 (5.25)	266.7 (10.50)	400.05 (15.75)	533.4 (21.00)	666.75 (26.25)
Weight Alum. kg (lbs.)	5 (12)	11 (24)	16 (35)	22 (49)	28 (61)
Weight Iron kg (lbs.)	20 (45)	41 (90)	62 (136)	82 (181)	103 (226)

See Mounting Bolt Kits for bolt information.

Series D6 and D8 Subplates

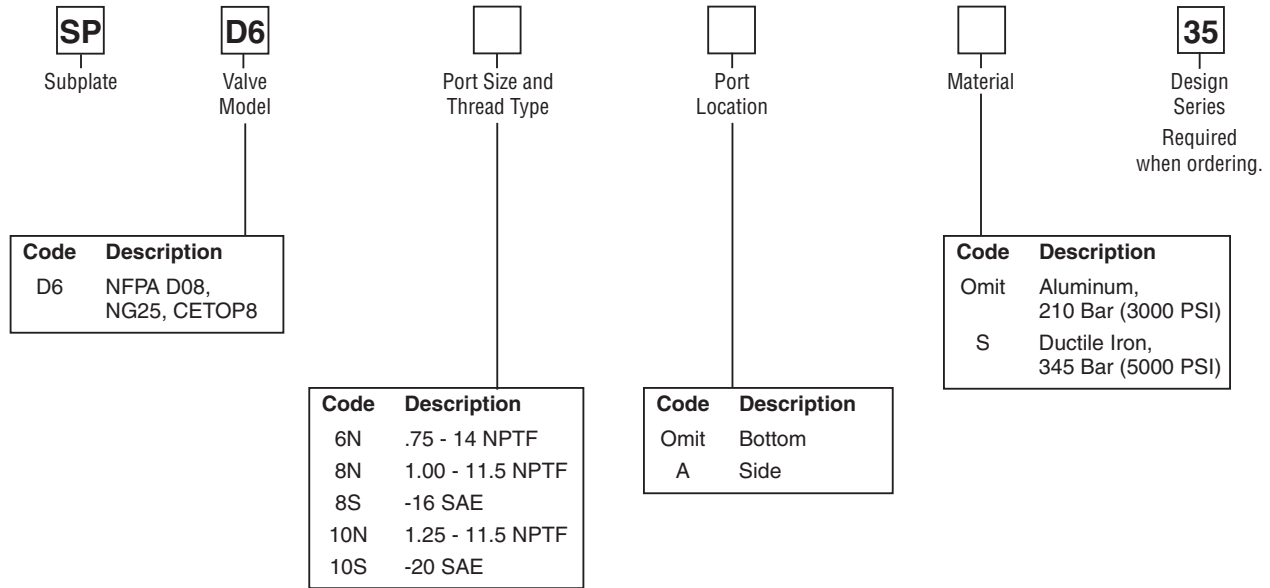

Mounting Hardware
 supplied with subplate includes:

Subplates	Mounting Hardware	Qty.
SPD66NA*	.50-13 UNC x	2
SPD68NA*	1.75 LG. SHCS	
SPD68SA*		
SPD610NA*	.50-13 UNC x	2
SPD610SA*	3.00 LG. SHCS	
SPD66N*	.50-13 UNC x	2
SPD68N*	1.50 LG. SHCS	
SPD68S*		
SPD610N*	.38-16 UNC x	4
SPD610S*	2.00 LG. SHCS	

Valve mounting threads:
 0.50-13 UNC x 1.19 DP.
 Used for SAE and NPTF ports.

Note: 35 Design Series subplates conform to NFPA mounting pattern specifications, but may be dimensionally different from previous design series.

Mounting Bolt Kits

UNC Bolt Kits for use with D6 and D8 Directional Control Valves & Sandwich Valves				
	Number of Sandwich Valves @ 2.75" (70mm) thickness			
	0	1	2	3
D6	BK227 2.50"	BK121 5.25"	BK122 8.00"	BK123 10.75"
D6 plus tapping plate	BK161 3.50"	BK170 6.25"	BK171 9.00"	BK172 11.75"
D8	BK228 3.00"	BK131 5.75"	BK132 8.50"	BK133 11.25"
D8 plus tapping plate	BK173 4.00"	BK174 6.75"	BK175 9.50"	BK114 12.125"

Note: All bolts are SAE grade 8, 1/2-13 UNC-3A thread, torque to 133 N.m. (100 ft.-lbs.)



Series D6 and D8 Manifolds

SP

Manifold

□

Number of Stations

D6

Valve Model

□

Port Size and Thread Type

□

Material

35

Design Series

Required when ordering.

Code	Description
1	No. of Stations
2	No. of Stations
3	No. of Stations
4	No. of Stations
5	No. of Stations

Code	Description
D6	NFPA D08, NG25, CETOP8

Code	Description
Omit	Aluminum, 210 Bar (3000 PSI)
S	Ductile Iron, 345 Bar (5000 PSI)

Code	Description	Port Size					Gage
		P, A, B	T	Y	X (opt.)		
N*	NPTF	1.00	1.25	.38	.25	.25	
S**	SAE	-16	-20	-8	-4	-6	

Mounting hardware supplied with manifold includes:
 (2) steel brackets
 For SAE and NPTF ports:
 (8) 1/2-13 UNC x 1.00 HHCS
 (8) .50 SAE N Series washers

* 0.25-18 NPT gage port plug included.
 ** -6 SAE gage port plug included.

Valve mounting threads:
 0.50-13 UNC x 1.19 DP.
 Used for SAE and NPTF ports.

Note: 35 Design Series manifolds conform to NFPA mounting pattern specifications, but may be dimensionally different from previous design series.

No. Stations	1	2	3	4	5
Wgt., Alum, kg (lbs.)	5.5 (12)	11.0 (24)	16.0 (35)	22.4 (49)	27.9 (61)
Wgt., Iron, kg (lbs.)	20.6 (45)	41.1 (90)	62.2 (136)	82.7 (181)	103.3 (226)

Mounting Bolt Kits

UNC Bolt Kits for use with D6 and D8 Directional Control Valves & Sandwich				
	Number of Sandwich @ 2.75" (70mm) thickness			
	0	1	2	3
D6	BK227 2.50"	BK121 5.25"	BK122 8.00"	BK123 10.75"
D6 plus tapping plate	BK161 3.50"	BK170 6.25"	BK171 9.00"	BK172 11.75"
D8	BK228 3.00"	BK131 5.75"	BK132 8.50"	BK133 11.25"
D8 plus tapping plate	BK173 4.00"	BK174 6.75"	BK175 9.50"	BK114 12.125"

Note: All bolts are SAE grade 8, 1/2-13 UNC-3A thread, torque to 133 N.m. (100 ft.-lbs.)

Dimensions

Inch equivalents for millimeter dimensions are shown in (**)

Cover Plate — NFPA D03

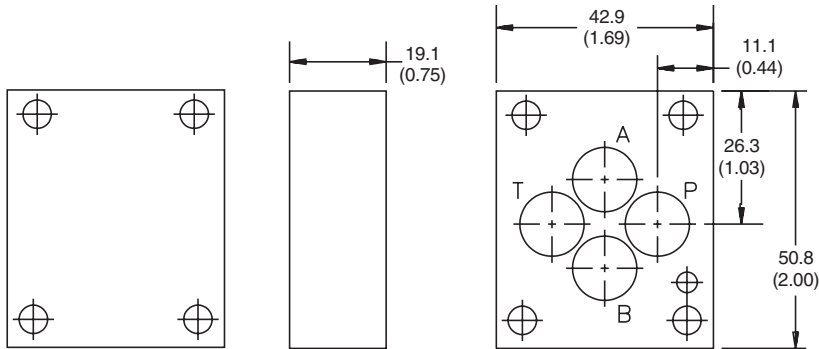

Note:
 Mounting hardware supplied with cover plate.
 Includes:
 2-012V-7 O-ring, Qty. 4
 $\varnothing 0.12$ x .25 long locating pin, Qty. 1
 10-24 UNC x 1.00 long SHCS, Qty. 4 (SPD2C1EN) or
 M5-0.8 x 25 mm long SHCS, Qty. 4 (SPD2C1MN)

Crossover Plate, P→T ports — NFPA D03

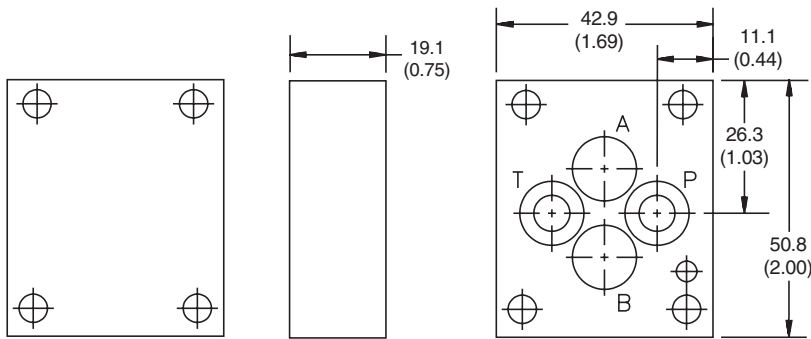

Note:
 Mounting hardware supplied with crossover plate.
 Includes:
 2-012V-7 O-ring, Qty. 4
 $\varnothing 0.12$ x .25 long locating pin, Qty. 1
 10-24 UNC x 1.00 long SHCS, Qty. 4 (SPD2D1EN) or
 M5-0.8 x 25 mm long SHCS, Qty. 4 (SPD2D1MN)

Crossover Plate, P→A and B→T ports — NFPA D03

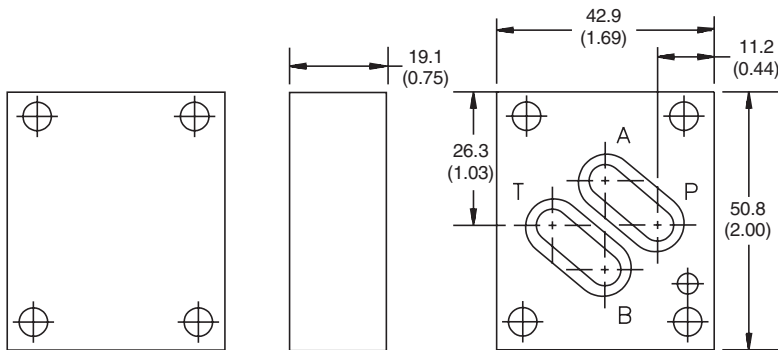

Note:
 Mounting hardware supplied with cover plate.
 Includes:
 2-016V-7 O-ring, Qty. 2
 $\varnothing 0.12$ x .25 long locating pin, Qty. 1
 10-24 UNC x 1.00 long SHCS, Qty. 4 (SPD2A1EN) or
 M5-0.8 x 25 mm long SHCS, Qty. 4 (SPD2A1MN)

Dimensions

Inch equivalents for millimeter dimensions are shown in (**)

Cover Plate — NFPA D05



C

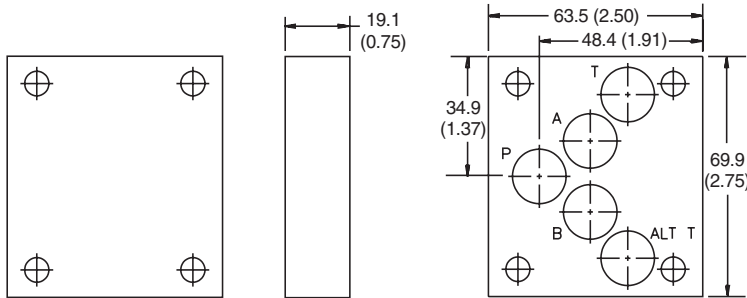

Note:
 Mounting hardware supplied with cover plate.
 Includes:
 2-014V-7 O-ring, Qty. 5
 0.25-20 UNC x 1.25 long SHCS, Qty. 4 (SPD3C1EN) or
 M6-1.0 x 30 mm long SHCS, Qty. 4 (SPD3C1MN)

Crossover Plate, P→T ports — NFPA D05

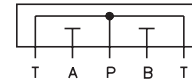
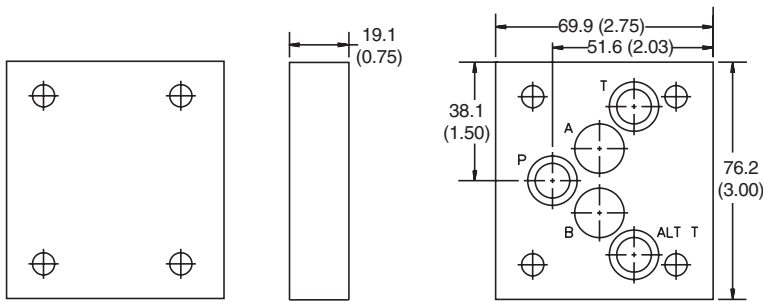

Note:
 Mounting hardware supplied with crossover plate.
 Includes:
 2-014V-7 O-ring, Qty. 5
 0.25-20 UNC x 1.25 long SHCS, Qty. 4 (SPD3D1EN) or
 M6-1.0 x 30 mm long SHCS, Qty. 4 (SPD3D1MN)

Crossover Plate, P→A and B→T ports — NFPA D05

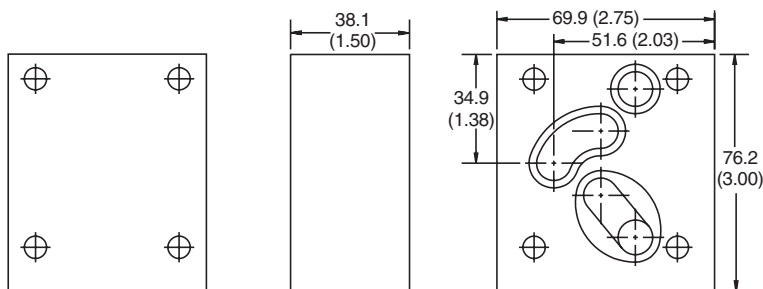

Note:
 Mounting hardware supplied with crossover plate.
 Includes:
 2-014V-7 O-ring, Qty. 1
 2-022V-7 +O-ring, Qty. 2
 0.25-20 UNC x 2.00 long SHCS, Qty. 4 (SPD3A1EN) or
 M6-1.0 x 50 mm long SHCS, Qty. 4 (SPD3A1MN)

Dimensions

Inch equivalents for millimeter dimensions are shown in (**)

Cover Plate — NFPA D05H

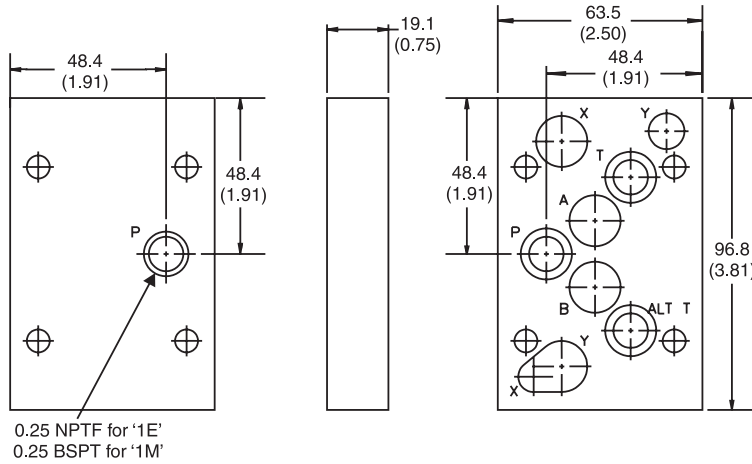

Note:

Mounting hardware supplied with cover plate.

Includes:

- 2-011V-7 O-ring, Qty. 1
- 2-014V-7 O-ring, Qty. 6
- 2-016V-7 O-ring, Qty. 1
- 0.25-18 NPTF plug, Qty. 1 (SPD31VC1EN only)
- 0.25-20 UNC x 1.25 long SHCS, Qty. 4 (SPD31VC1EN) or
- M6-1.0 x 30 mm long SHCS, Qty. 4 (SPD31VC1MN)

Crossover Plate, P→T ports — NFPA D05H

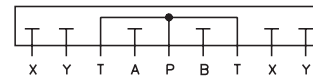
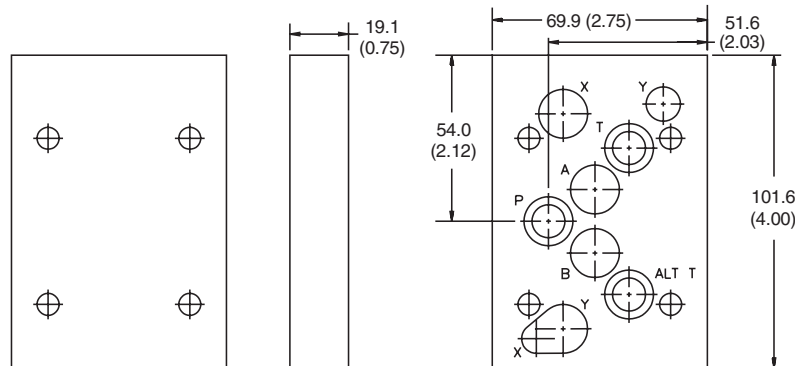

Note:

Mounting hardware supplied with crossover plate.

Includes:

- 2-011V-7 O-ring, Qty. 1
- 2-014V-7 O-ring, Qty. 6
- 2-016V-7 O-ring, Qty. 1
- 0.25-20 UNC x 1.25 long SHCS, Qty. 4 (SPD31VD1EN) or
- M6-1.0 x 30 mm long SHCS, Qty. 4 (SPD31VD1MN)

Crossover Plate, P→A and B→T ports — NFPA D05H

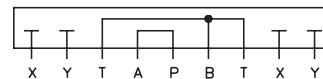
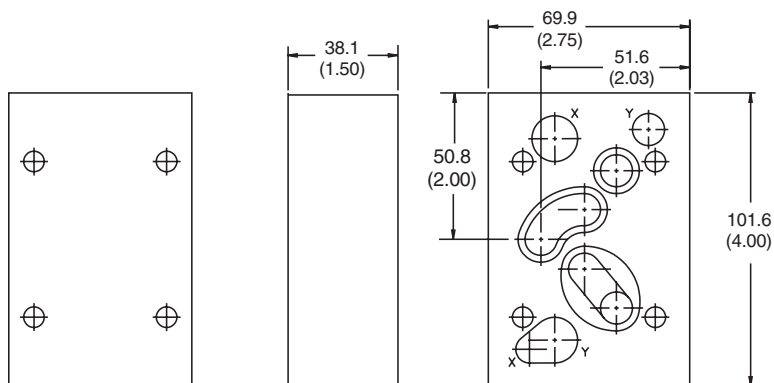

Note:

Mounting hardware supplied with crossover plate.

Includes:

- 2-011V-7 O-ring, Qty. 1
- 2-014V-7 O-ring, Qty. 2
- 2-016V-7 O-ring, Qty. 1
- 2-022V-7 O-ring, Qty. 2
- 0.25-20 UNC x 2.00 long SHCS, Qty. 4 (SPD31VA1EN) or
- M6-1.0 x 50 mm long SHCS, Qty. 4 (SPD31VA1MN)

Dimensions

Inch equivalents for millimeter dimensions are shown in (**)

Cover Plate — NFPA D08

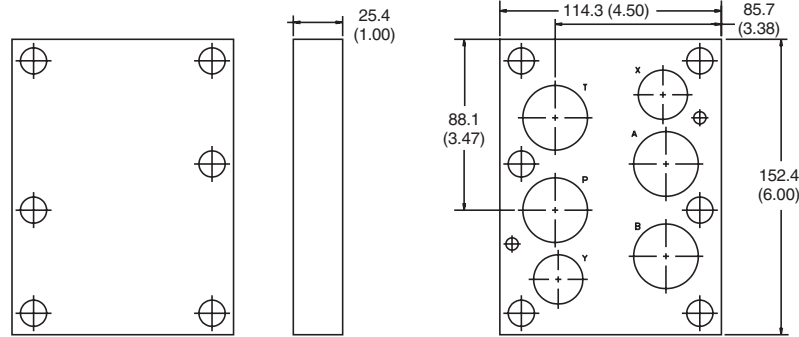

Note:

Mounting hardware supplied with cover plate.

Includes:

- 2-210V-7 O-ring, Qty. 2
- 2-215V-7 O-ring, Qty. 4
- 0.50-13 UNC x 1.75 long SHCS, Qty. 6 (SPD6C1EN) or M12-1.75 x 45 mm long SHCS, Qty. 6 (SPD6C1MN)
- 0.25 x 0.50 long locating pins, Qty. 2

Crossover Plate, P→T ports — NFPA D08

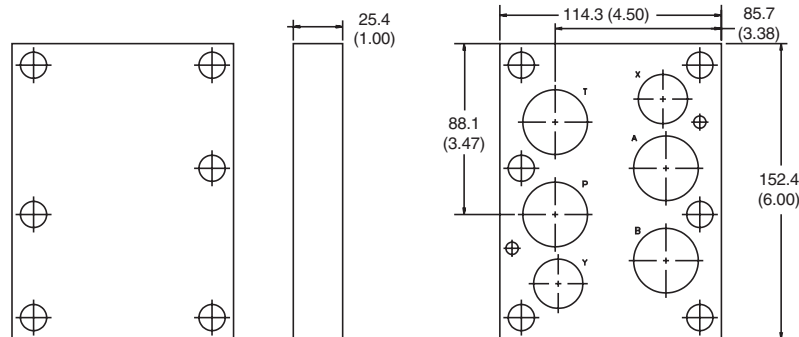

Note:

Mounting hardware supplied with cover plate.

Includes:

- 2-210V-7 O-ring, Qty. 2
- 2-215V-7 O-ring, Qty. 4
- 0.50-13 UNC x 1.75 long SHCS, Qty. 6 (SPD6C1EN) or M12-1.75 x 45 mm long SHCS, Qty. 6 (SPD6C1MN)
- 0.25 x 0.50 long locating pins, Qty. 2

Crossover Plate, P→A and B→T ports — NFPA D08

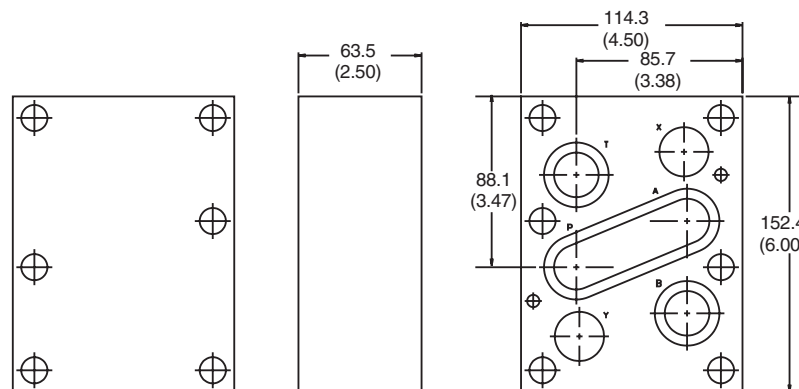

Note:

Mounting hardware supplied with crossover plate.

Includes:

- 2-210V-7 O-ring, Qty. 2
- 2-215V-7 O-ring, Qty. 2
- 2-231V-7 O-ring, Qty. 1
- 0.50-13 UNC x 3.50 long SHCS, Qty. 6 (SPD6A1EN) or M12-1.75 x 90 mm long SHCS, Qty. 6 (SPD6A1MN)
- 0.25 x 0.50 long locating pins, Qty. 2

Dimensions

Inch equivalents for millimeter dimensions are shown in (**)

Tapping Plate, A and B ports — NFPA D03

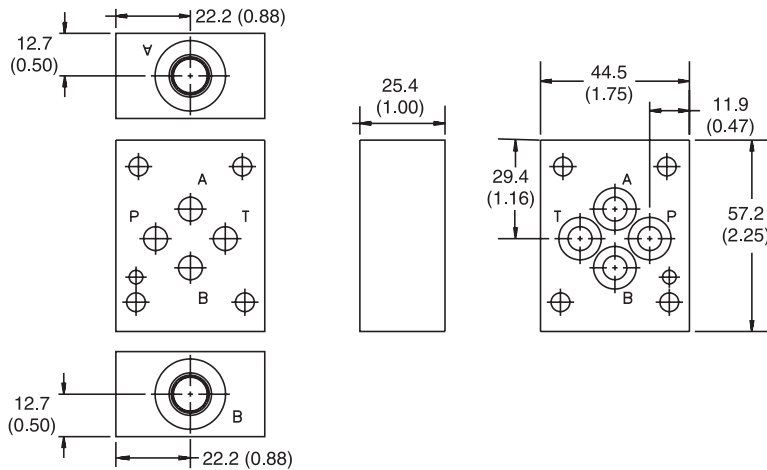

Note:
 Interface seal kit provided with tapping plate.
Includes:
 2-012V-7 O-ring, Qty. 4
 Ø0.12 x .25 long locating pin, Qty. 1
 0.25-18 NPTF Plug, Qty. 1 (NPTF port only)
 -4 SAE Hex Socket Plug, Qty., 1 (SAE port only)



Tapping Plate, P and T ports — NFPA D03

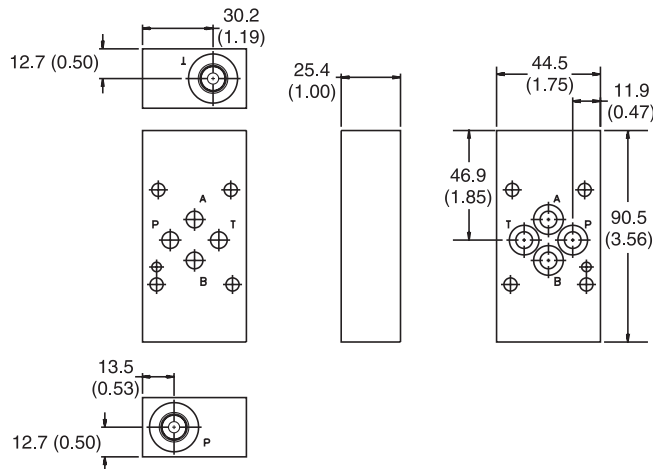

Note:
 Interface seal kit provided with tapping plate.
Includes:
 2-012V-7 O-ring, Qty. 4
 Ø0.12 x .25 long locating pin, Qty. 1
 0.25-18 NPTF Plug, Qty. 1 (NPTF port only)
 -4 SAE Hex Socket Plug, Qty., 1 (SAE port only)

Tapping Plate, A and B ports — NFPA D05

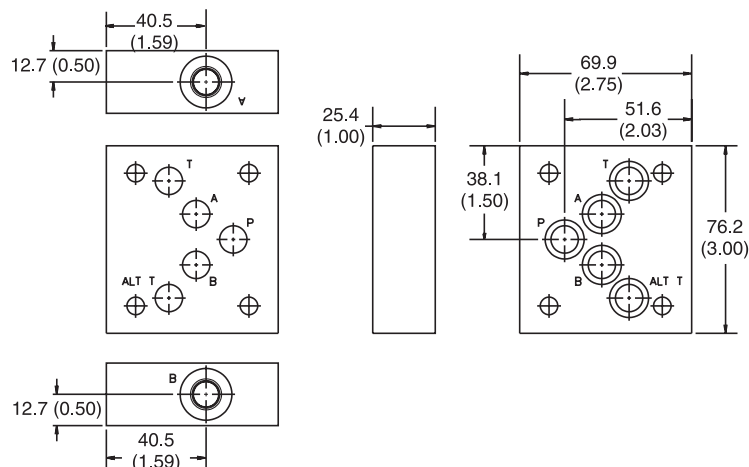

Note:
 Interface seal kit provided with tapping plate.
Includes:
 2-014V-7 O-ring, Qty. 5
 0.25-18 NPTF Plug, Qty. 1 (NPTF port only)
 -4 SAE Hex Socket Plug, Qty., 1 (SAE port only)

Dimensions

Inch equivalents for millimeter dimensions are shown in (**)

Tapping Plate, P and T ports — NFPA D05

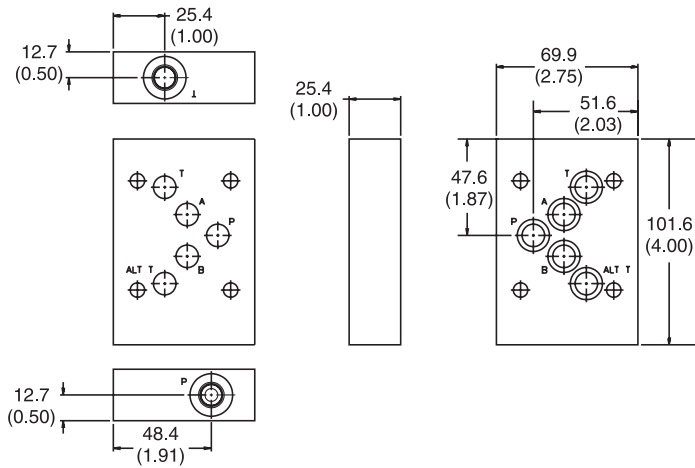

Note:
 Interface seal kit provided with tapping plate.
 Includes:
 2-014V-7 O-ring, Qty. 5
 0.25-18 NPTF Plug, Qty. 1 (NPTF port only)
 -4 SAE Hex Socket Plug, Qty., 1 (SAE port only)

Tapping Plate, A and B ports — NFPA D05H and D05HE (E)

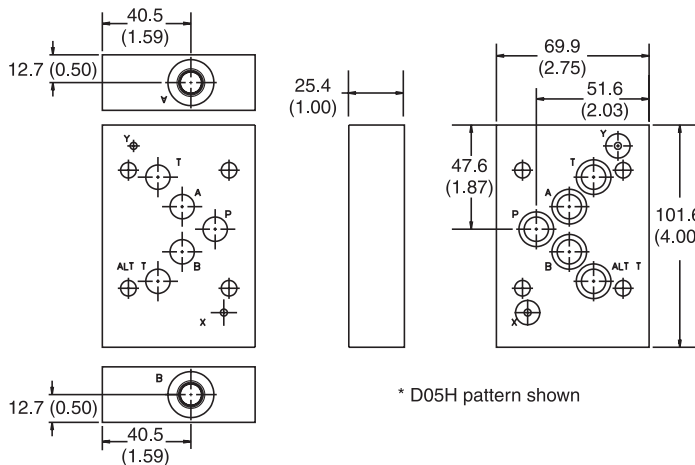

Note:
 Interface seal kit provided with tapping plate.
 Includes:
 SPD31VT2*W* :
 2-011V-7 O-ring, Qty. 2
 2-014V-7 O-ring, Qty. 5
 SPD31DT2*W*:
 2-014V-7 O-ring, Qty. 7
 0.25-18 NPTF Plug, Qty. 1 (NPTF port only)
 -4 SAE Hex Socket Plug, Qty., 1 (SAE port only)

Tapping Plate, P and T ports — NFPA D05H and D05HE

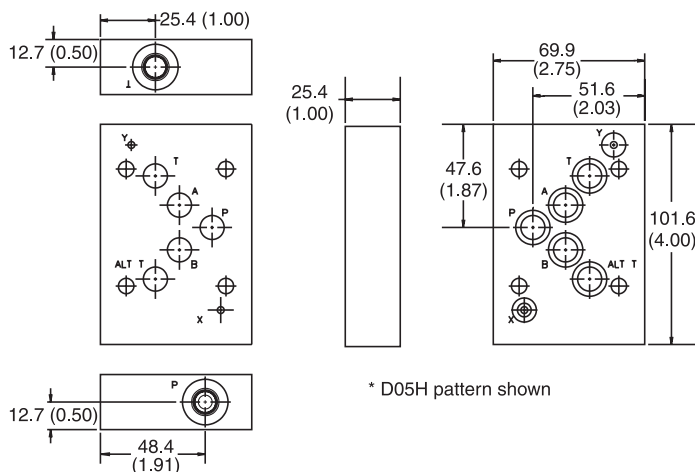

Note:
 Interface seal kit provided with tapping plate.
 Includes:
 SPD31VT2*P*:
 2-011V-7 O-ring, Qty. 2
 2-014V-7 O-ring, Qty. 5
 SPD31DT2*P*:
 2-014V-7 O-ring, Qty. 7
 0.25-18 NPTF Plug, Qty. 1 (NPTF port only)
 -4 SAE Hex Socket Plug, Qty., 1 (SAE port only)

Dimensions

Inch equivalents for millimeter dimensions are shown in (**)

Tapping Plate, X and Y ports — NFPA D05H and D05HE

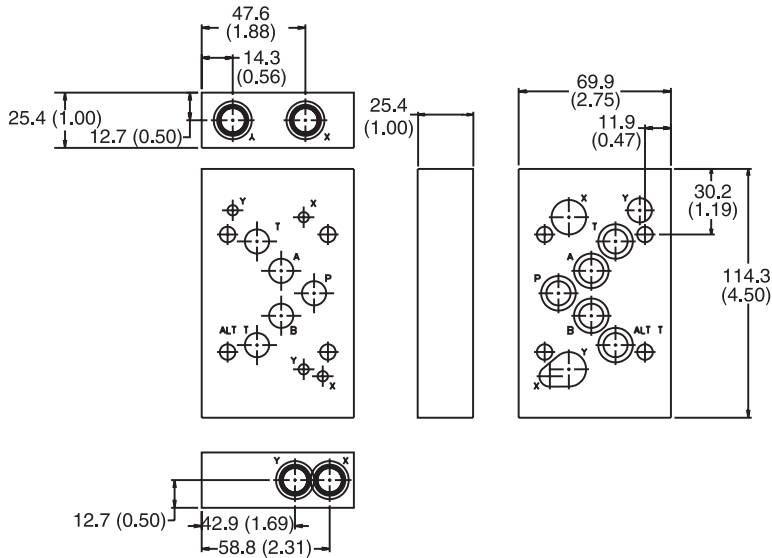

Note:

Interface seal kit provided with tapping plate.

Includes:

- 2-011V-7 O-ring, Qty. 1
- 2-014V-7 O-ring, Qty. 6
- 2-016V-7 O-ring, Qty. 1
- 0.25-18 NPTF Plug, Qty. 3 (NPTF port only)
- 4 SAE Hex Socket Plug, Qty. 3 (SAE port only)

Tapping Plate, A and B ports — NFPA D08

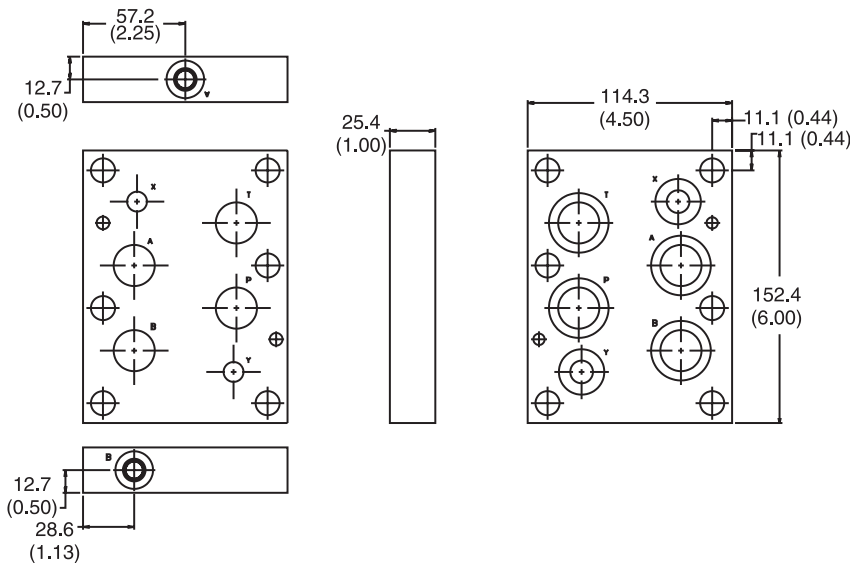

Note:

Interface seal kit provided with tapping plate.

Includes:

- 2-210V-7 O-ring, Qty. 2
- 2-215V-7 O-ring, Qty. 4
- ∅.25 x .50 long locating pin, Qty. 2
- 0.25-18 NPTF Plug, Qty. 1 (NPTF port only)
- 4 SAE Hex Socket Plug, Qty. 1 (SAE port only)

Dimensions

Inch equivalents for millimeter dimensions are shown in (**)

Tapping Plate, P and T ports — NFPA D08

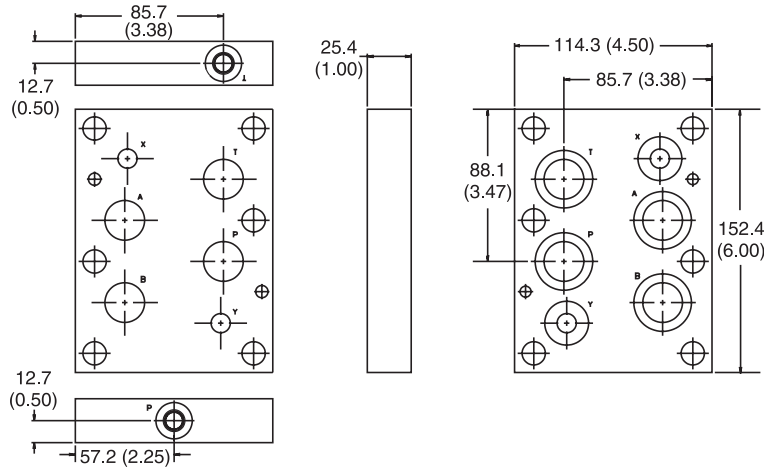

Note:
 Interface seal kit provided with tapping plate.
 Includes:
 2-210V-7 O-ring, Qty. 2
 2-215V-7 O-ring, Qty. 4
 Ø.25 x .50 long locating pin, Qty. 2
 0.25-18 NPTF Plug, Qty. 1 (NPTF port only)
 -4 SAE Hex Socket Plug, Qty. 1 (SAE port only)

Tapping Plate, X and Y ports — NFPA D08

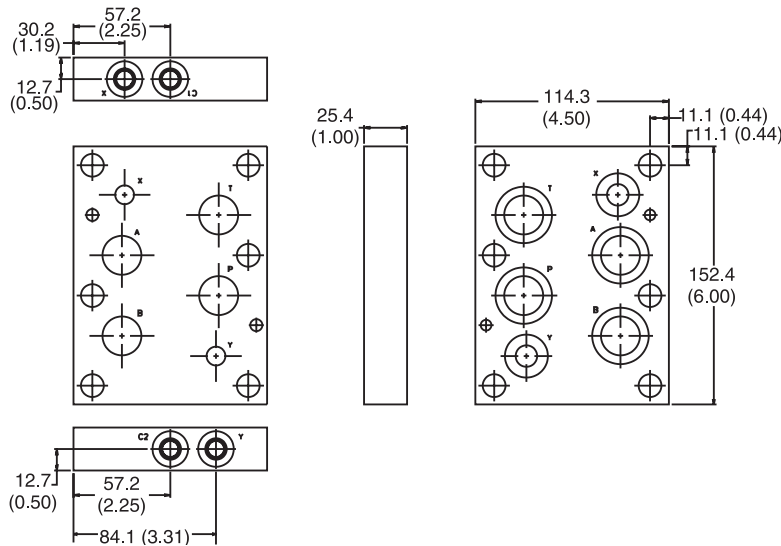

Note:
 Interface seal kit provided with tapping plate.
 Includes:
 2-210V-7 O-ring, Qty. 2
 2-215V-7 O-ring, Qty. 4
 Ø.25 x .50 long locating pin, Qty. 2
 0.25-18 NPTF Plug, Qty. 3 (NPTF port only)
 -4 SAE Hex Socket Plug, Qty. 3 (SAE port only)

Ordering Information
Series D1V Tapping and Cover Plates

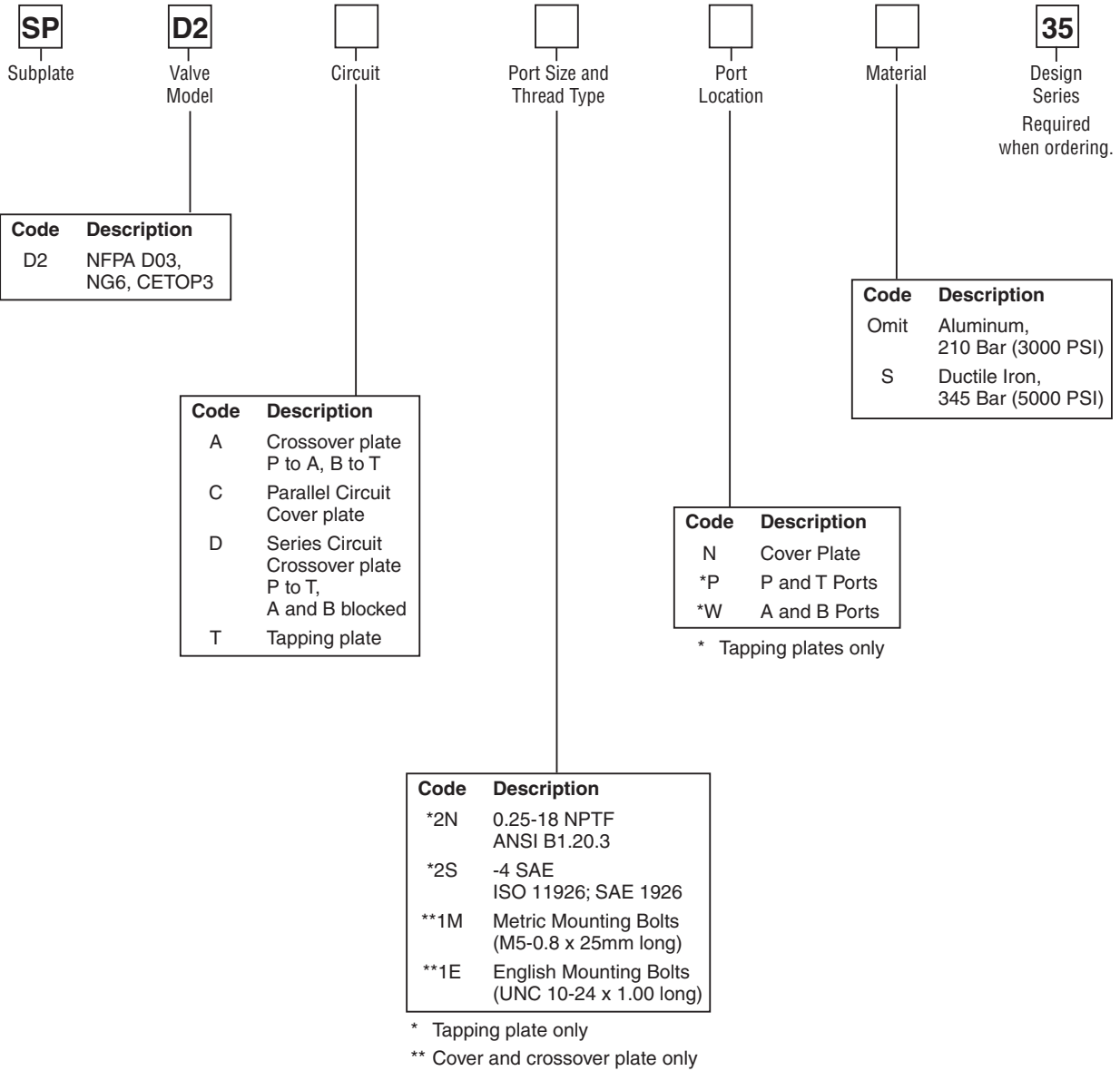

Ordering Information
Series D3 Tapping and Cover Plates

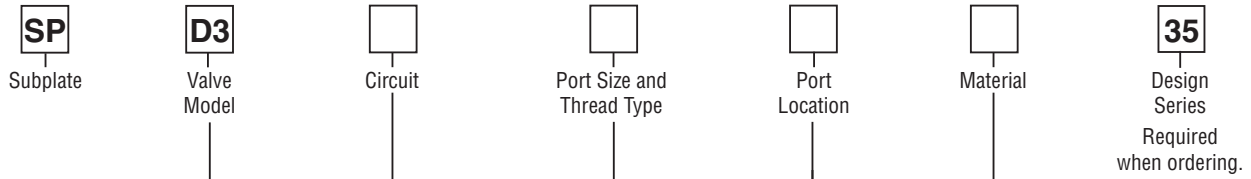

Code	Description
D3	NFPA D05, NG10, CETOP5

Code	Description
A	Crossover plate P to A, B to T
C	Parallel Circuit Cover plate
D	Series Circuit Crossover plate P to T, A and B blocked
T	Tapping plate

Code	Description
Omit	Aluminum, 210 Bar (3000 PSI)
S	Ductile Iron, 345 Bar (5000 PSI)

Code	Description
N	Cover Plate
*P	P and T Ports
*W	A and B Ports

* Tapping plates only

Code	Description
*2N	0.25-18 NPTF ANSI B1.20.3
*2S	-4 SAE ISO 11926; SAE 1926
**1M	Metric Mounting Bolts (M6-1.0 x 30mm lg. SHCS Circuits 'C' and 'D' only) (M6-1.0 x 50mm lg. SHCS Circuit 'A' Only)
**1E	English Mounting Bolts (UNC .25-20 x 1.25 lg. SHCS Circuits 'C' and 'D' only) (UNC .25-20 x 2.00 lg. SHCS Circuit 'A' Only)

* Tapping plate only

** Cover and crossover plate only



**Ordering Information
 Series D31 Tapping and Cover Plates**

SP

Subplate

Valve Model

Circuit

Port Size and Thread Type

Port Location

Material

35

Design Series

Required when ordering.

Code	Description
D31V	NFPA D05H, D3P
D31D*	NFPA D05HE, NG10, CETOP5H

* Only available with tapping plates. Model D31V cover and crossover plates can be used for D05H and D05HE mounting patterns interchangeably.

Code	Description
Omit	Aluminum, 210 Bar (3000 PSI)
S	Ductile Iron, 345 Bar (5000 PSI)

Code	Description
A	Crossover plate P to A, B to T
C	Parallel Circuit Cover plate
D	Series Circuit Crossover plate P to T, A and B blocked
T	Tapping plate

Code	Description
N	Cover Plate
*P	P and T Ports
*W	A and B Ports
*X	X and Y Ports

* Tapping plates only

Code	Description
*2N	0.25-18 NPTF ANSI B1.20.3
*2S	-4 SAE ISO 11926; SAE 1926
**1M	Metric Mounting Bolts (M6-1.0 x 30mm lg. SHCS Circuits 'C' and 'D' only) (M6-1.0 x 50mm lg. SHCS Circuit 'A' Only)
**1E	English Mounting Bolts (UNC .25-20 x 1.25 lg. SHCS Circuits 'C' and 'D' only) (UNC .25-20 x 2.00 lg. SHCS Circuit 'A' Only)

* Tapping plate only

** Cover and crossover plate only



Ordering Information
Series D6 and D8 Tapping and Cover Plates

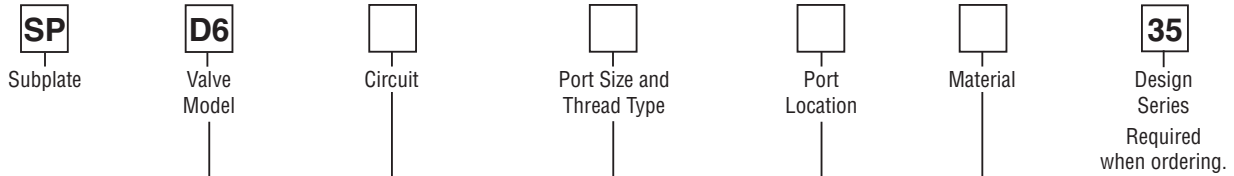

Code	Description
D6	NFPA D08, NG25, CETOP8

Code	Description
A	Crossover plate P to A, B to T
C	Parallel circuit Cover plate
D	Series circuit Crossover plate P to T, A and B blocked
T	Tapping plate

Code	Description
Omit	Aluminum, 210 Bar (3000 PSI)
S	Ductile Iron, 345 Bar (5000 PSI)

Code	Description
N	Cover Plate
*P	P and T Ports
*W	A and B Ports
*X	X and Y Ports

* Tapping plates only

Code	Description
*2N	0.25-18 NPTF ANSI B1.20.3
*2S	-4 SAE ISO 11926; SAE 1926
**1M	Metric Mounting Bolts (M12-1.75 x 45mm lg. SHCS Circuit 'C' only) (M12-1.75 x 60mm lg. SHCS Circuit 'D' only) (M12-1.75 x 90mm lg. SHCS Circuit 'A' only)
**1E	English Mounting Bolts (UNC .50-13 x 1.75 lg. SHCS Circuit 'C' only) (UNC .50-13 x 2.25 lg. SHCS Circuit 'D' only) (UNC .50-13 x 3.50 lg. SHCS Circuit 'A' only)

* Tapping plate only

** Cover and crossover plate only



Mounting Pattern — NFPA D03, NG6, CETOP 3

Inch equivalents for millimeter dimensions are shown in (**)

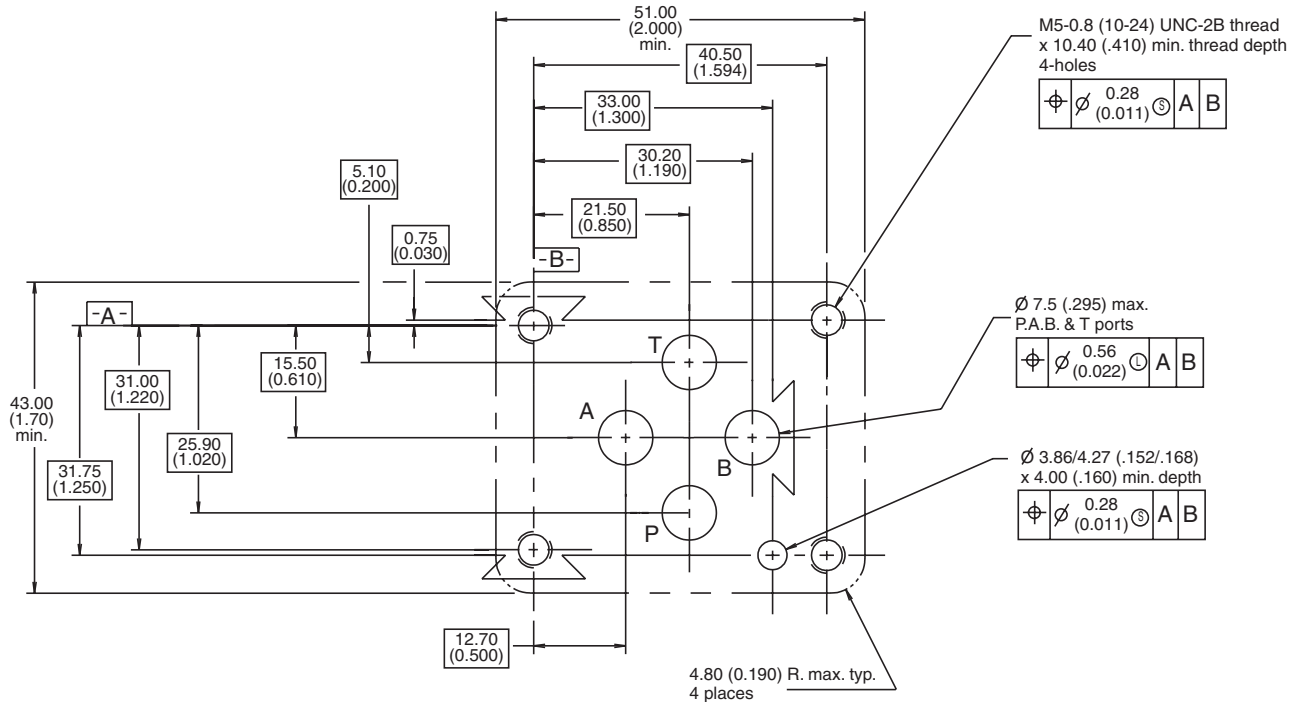

Mounting Pattern — NFPA D05, NG5, CETOP 5

Inch equivalents for millimeter dimensions are shown in (**)

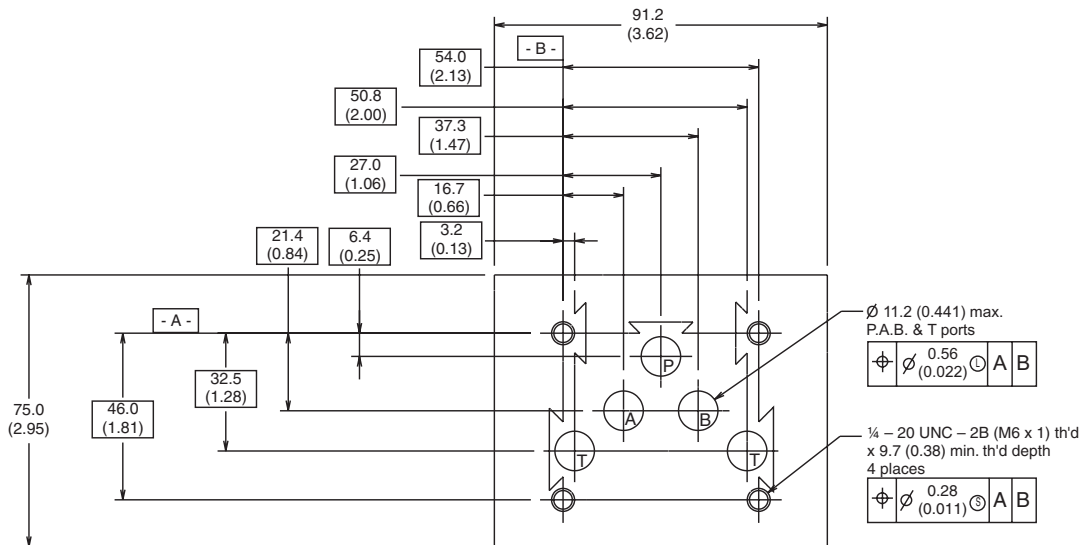

Mounting Pattern — NFPA D05H, NG10, CETOP 5H

Inch equivalents for millimeter dimensions are shown in (**)

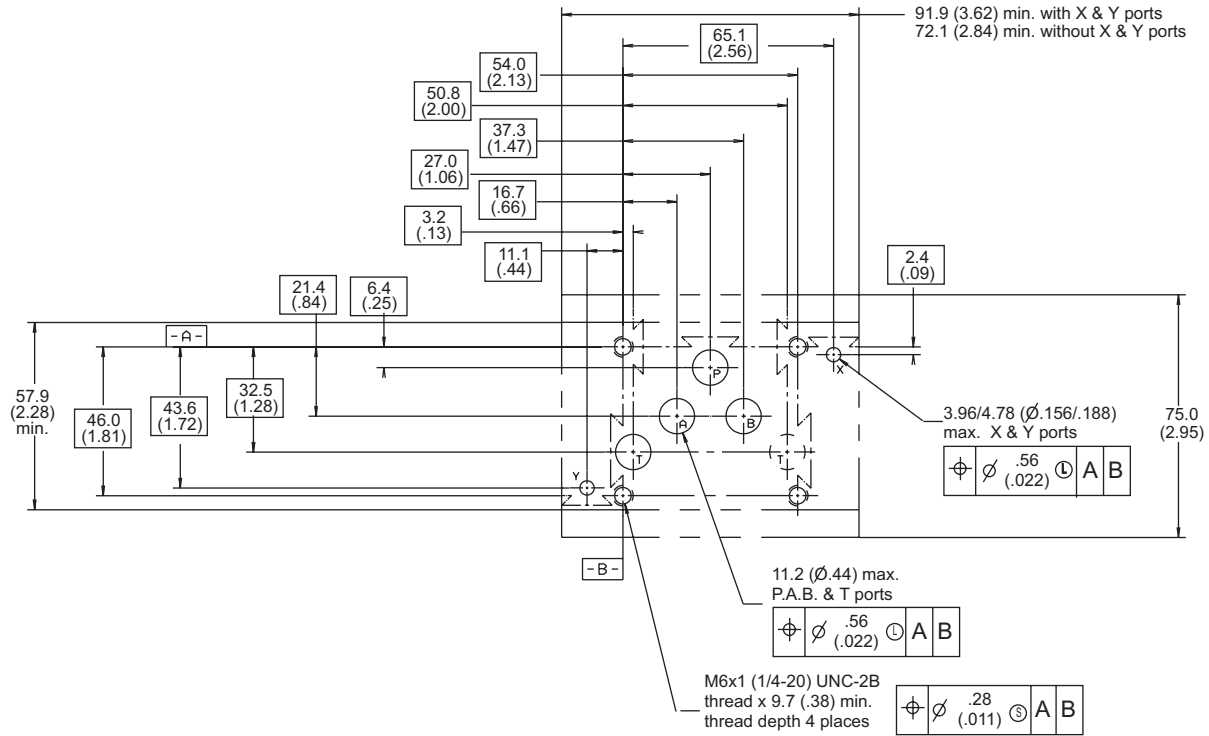

Mounting Pattern — NFPA D05HE, NG10, CETOP 5H

Inch equivalents for millimeter dimensions are shown in (**)

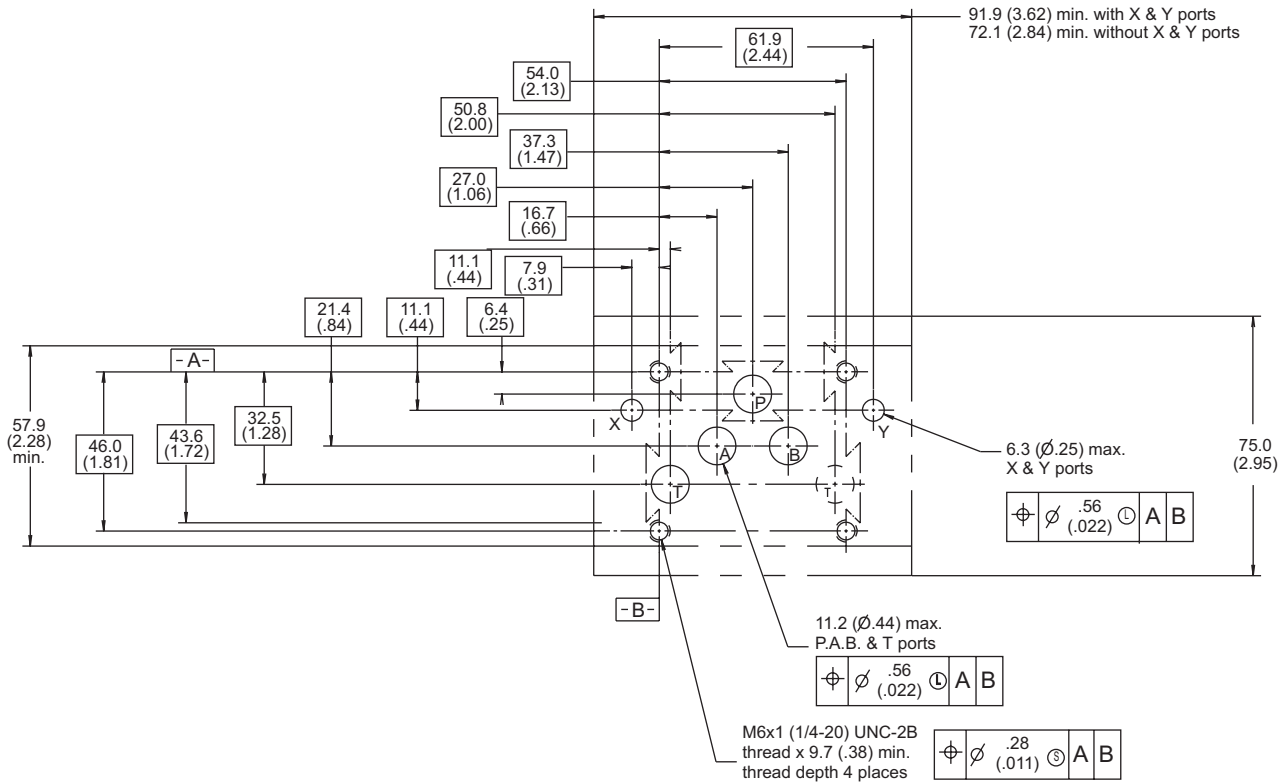

Mounting Pattern — NFPA D07, NG16, CETOP 7

Inch equivalents for millimeter dimensions are shown in (**)

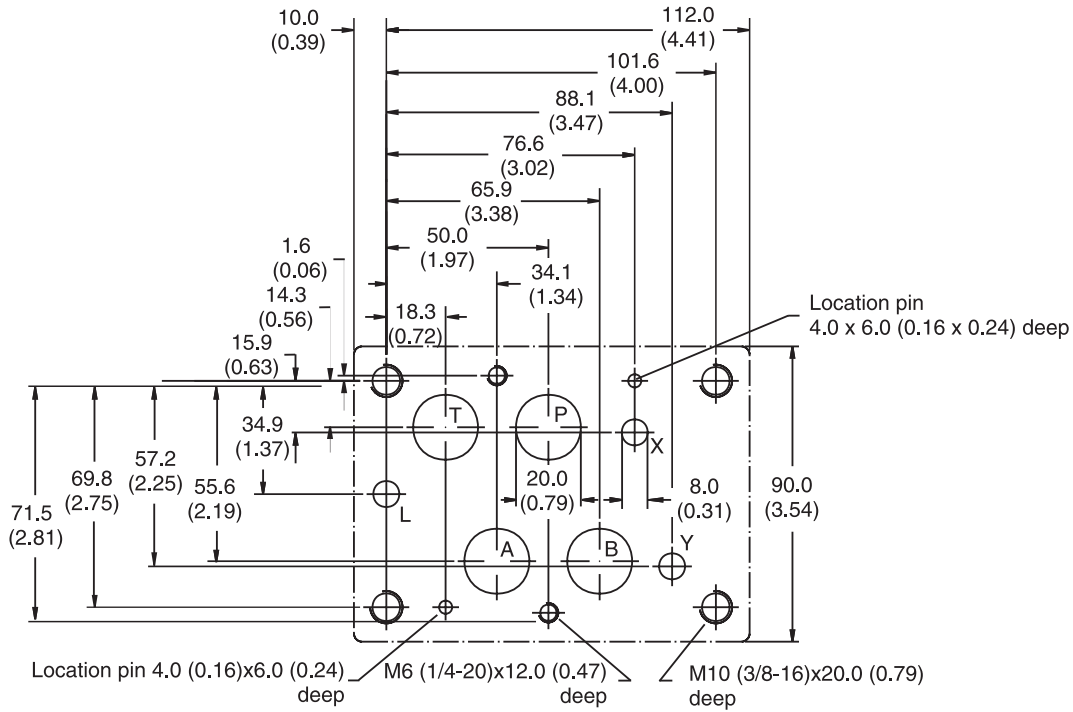

Mounting Pattern — NFPA D08, NG25, CETOP 8

Inch equivalents for millimeter dimensions are shown in (**)

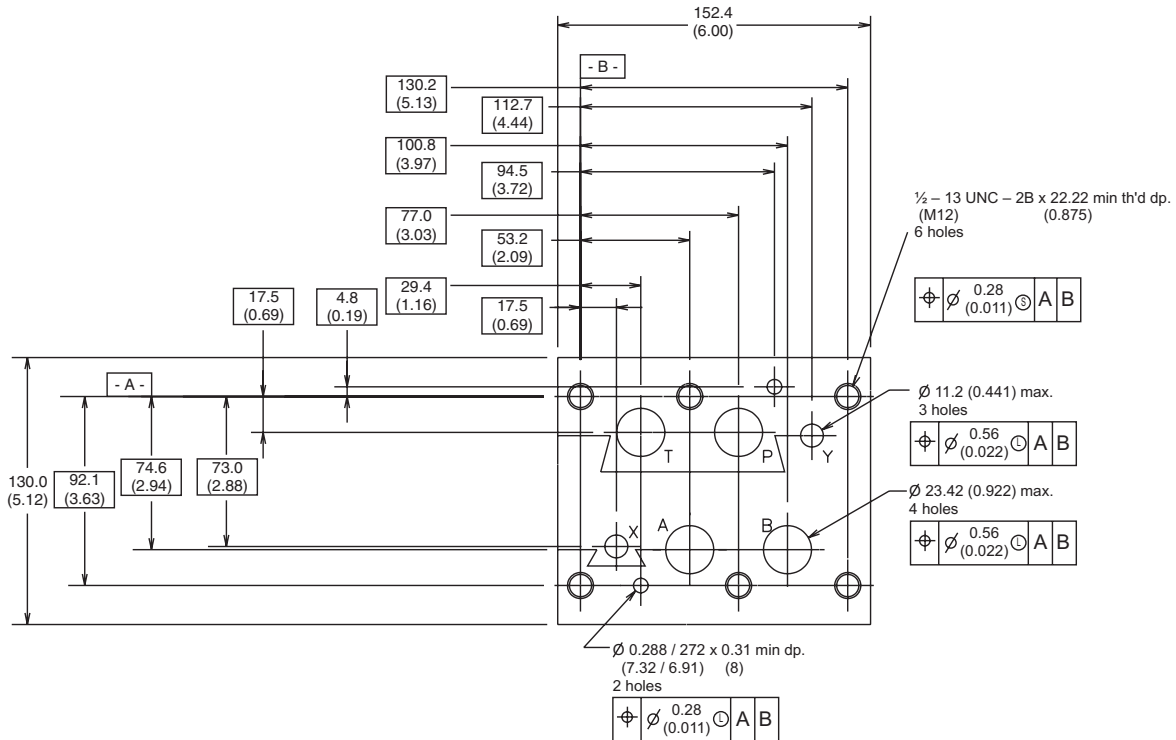

General Description

Series PSB electrohydraulic pressure switches are high performance devices that provide an electrical signal when sensed pressure rises above or falls below the selected setting. Maximum operating pressure is 315 Bar (4560 PSI) for all models.

Operation

Sensed pressure acts against a piston and spring plate assembly that is opposed by an adjustable spring force. When the pressure against the piston exceeds that of the adjustable spring, the plate moves and actuates a microswitch. The desired operating pressure is adjusted via a setscrew or hand knob. A tamper resistant keylock option is also available with the setscrew type adjuster. The electric element is a high quality micro switch with snap-action contact. Three terminals permit application as "on", "off" or "change-over" switch. The electric connection is made with a 3-pole plug-in connector to DIN 43650 with ground. The plug-in connector is also available with an indicator light.

Features

- **Four Separate Adjustable Pressure Range Options** — Enables operator to precisely select the desired pressure setting.
- **Hydraulically Dampened Piston** — Provides accurate response and extended service life.
- **Flange Type Mounting Style** — Provides great flexibility for mounting with manifolds, sandwich plates or direct line connections.
- **Optional Keylock Adjustment** — Prevents tampering or unauthorized adjustments in critical applications.
- **Robust Cast Iron Construction** — A rugged, yet compact, product designed to provide long service life in demanding applications.
- **IP 65 (Nema 4) Class Electrical Protection** — Maintains integrity against moisture in spray or splashdown situations.

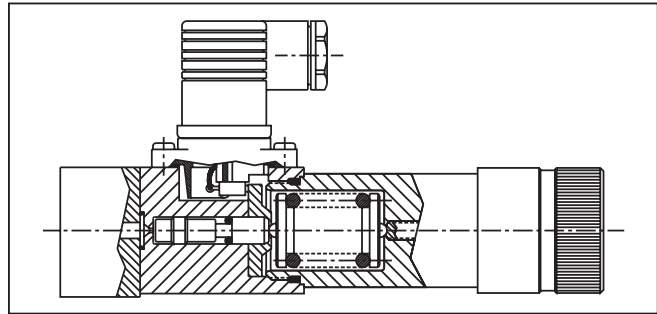
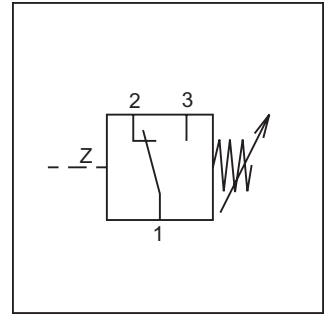

Specifications

Type	Plunger type switch
Mounting	Flange mounting or fitted to a level face
Mounting Position	No restrictions
Operating Pressure	Maximum 315 Bar (4560 PSI)
Actuating Pressure Differential	See performance curves
Duty Cycle	Maximum 1/s
Operating Temp. Range (Ambient)	0 to 80° C (32 to 176° F)
Viscosity Range	12 to 400 cSt / mm ² /s (56 to 1854 SSU)
Filtration	Recommend ISO 4406 Code, 18/16/13 or better
Electrical Connection	Plug-in connector to DIN 43650
Insulation	IP 65 (Nema 4)
Contact Load Carrying Capacity	5 A at 250 VAC; 1 A at 50 VDC; .02 A at 250 VDC

Note: For inductive DC loads a diode should be used to increase service life.

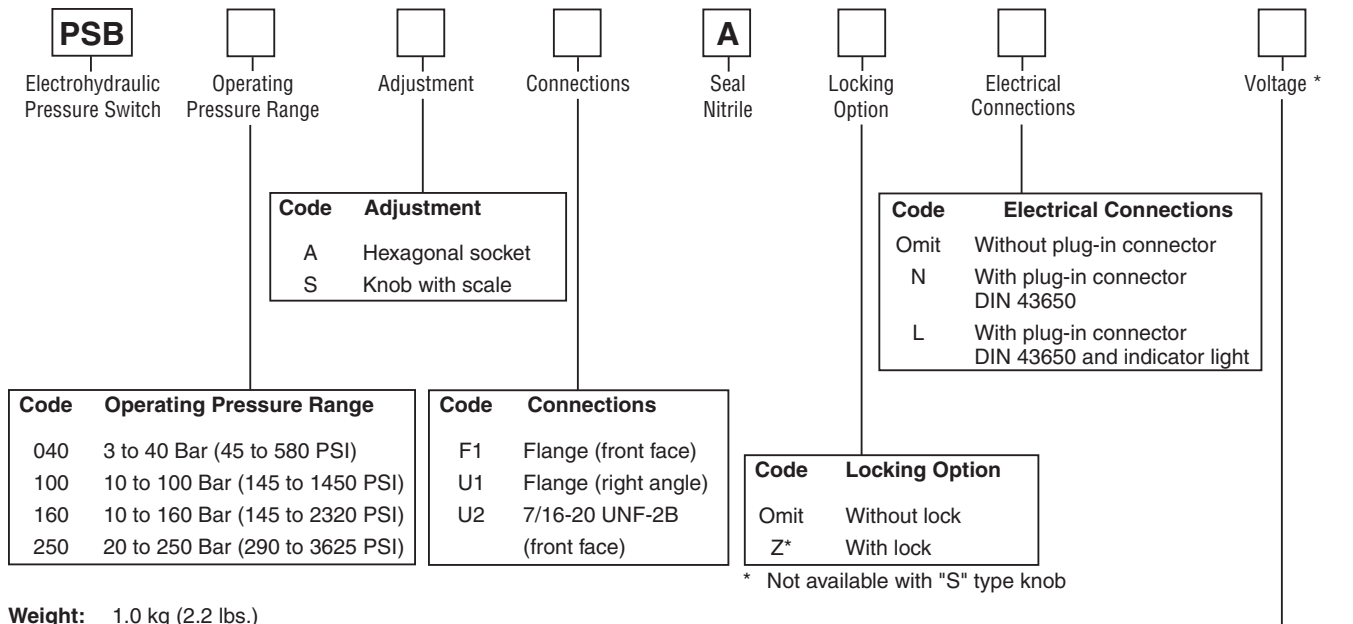

Weight: 1.0 kg (2.2 lbs.)

Mounting Bolts
 (2 each required)

	F1	U1/U2
Inch	10 x 353 (10-24 x 2.50)	10 x 218 (10-24 x 2.00)
Metric	M5 x 60	M5 x 50

Code	Voltage
G024	Plug-in connector w/light, 24VDC
W115	Plug-in connector w/light, 115VAC
W230	Plug-in connector w/light, 230VAC

* Only for the Code "L" Models.

Sandwich Plate to NG6, NFPA D03 Pattern

Allows PSB switches to be used in stacking assemblies with Sandwich style valves.

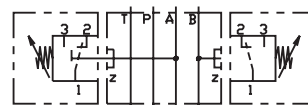
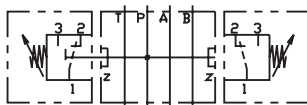

H06PSB-993 -- Pressure switch to P connection

H06PSB-994 -- Pressure switch to A or B or A and B connection

Inch equivalents for millimeter dimensions are shown in (**)

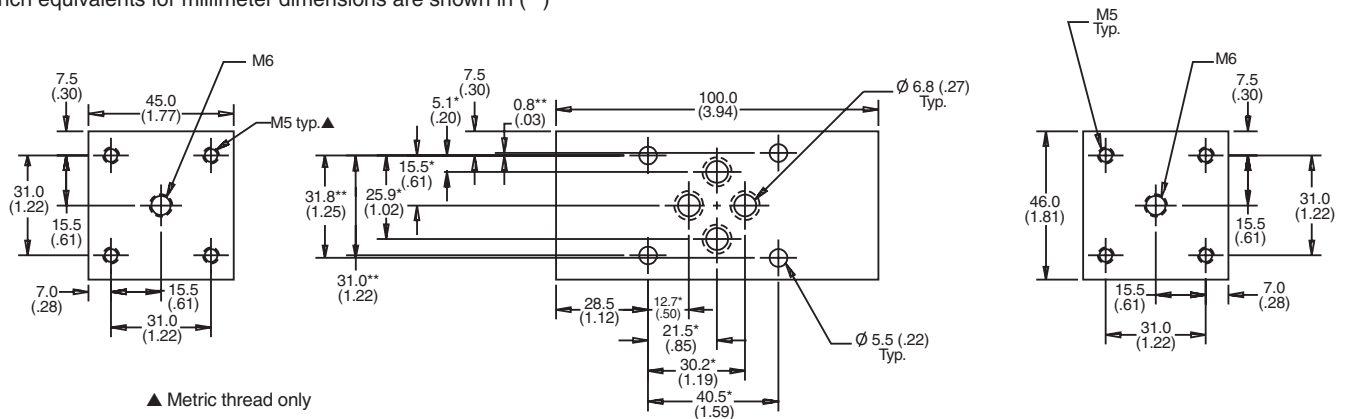

▲ Metric thread only

Note:
 * Tolerance on these dimensions +/- 0.2
 ** Tolerance on these dimensions +/- 0.1



Performance Curves

PSB 040

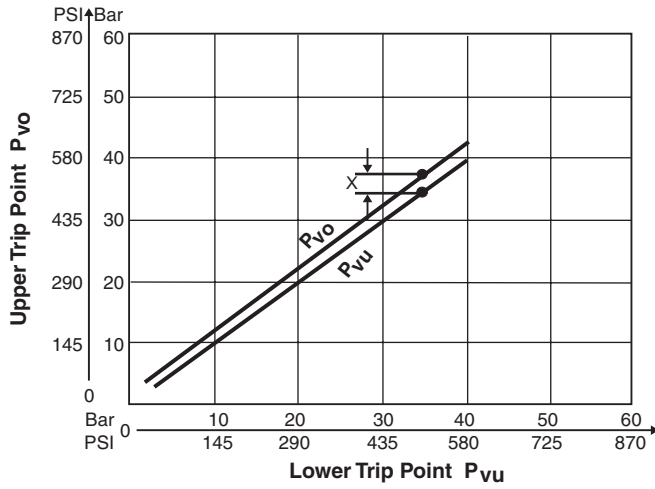

PSB 100

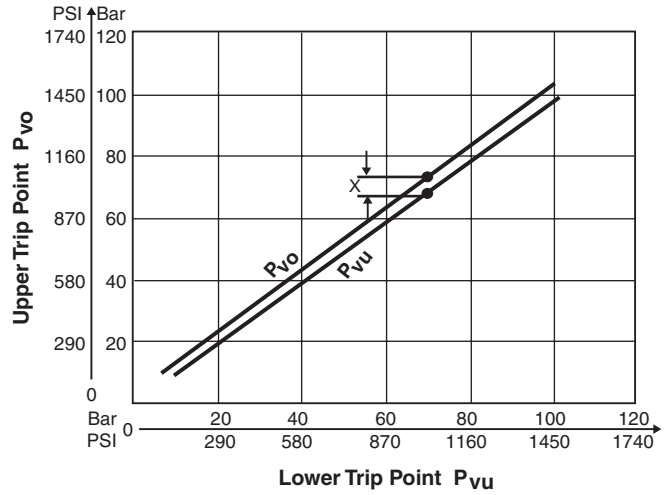

X = Switching Pressure Difference

PSB 160

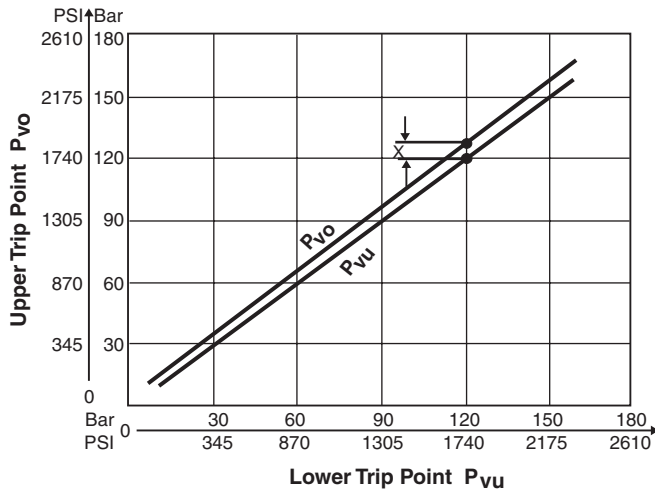

PSB 250

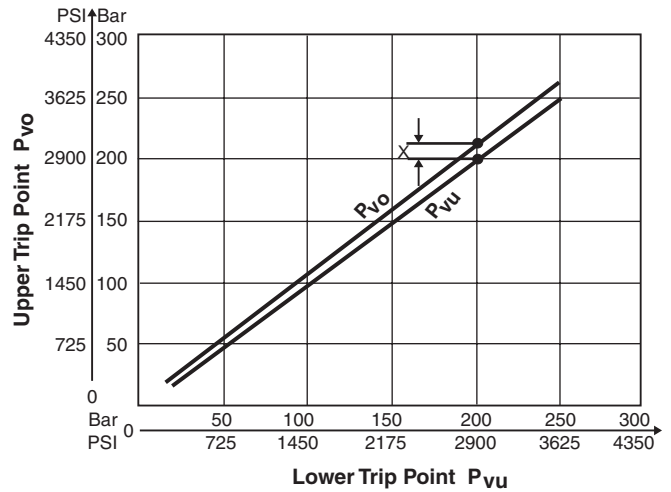

X = Switching Pressure Difference

Electrical Connections

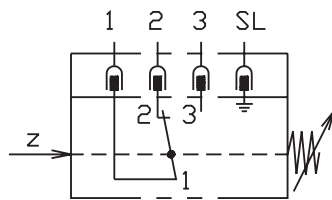

Connection 'N'

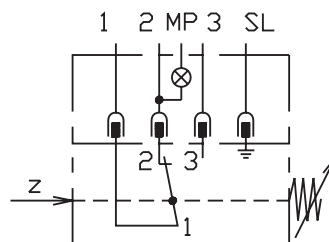

Connection 'L'

Inch equivalents for millimeter dimensions are shown in (**)

F1

Mounting Pattern

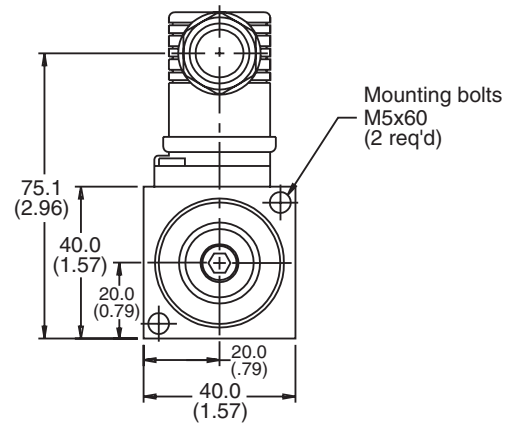
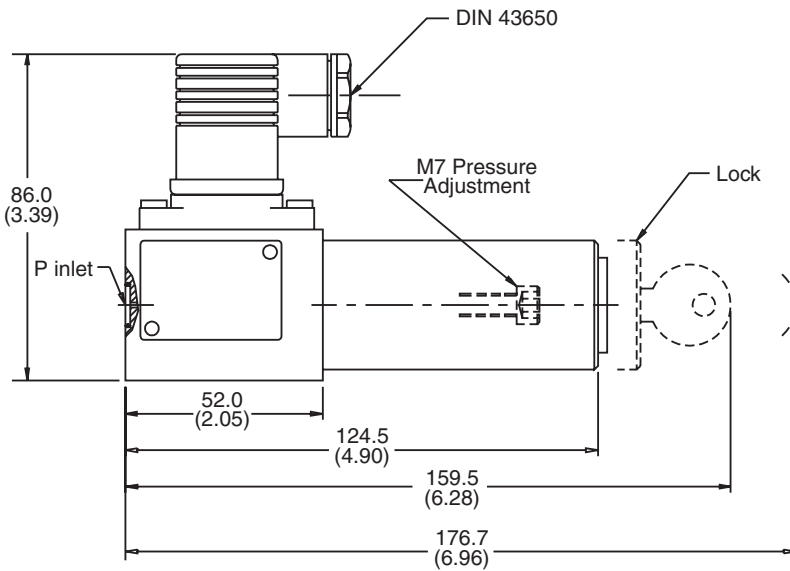
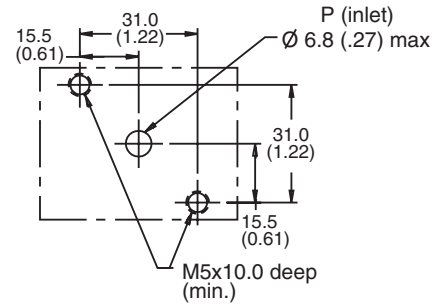
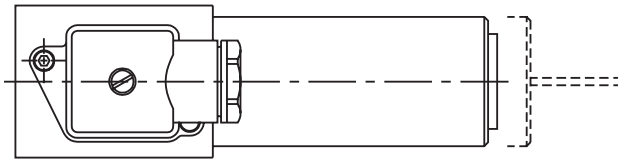

Inch equivalents for millimeter dimensions are shown in (**)

U1

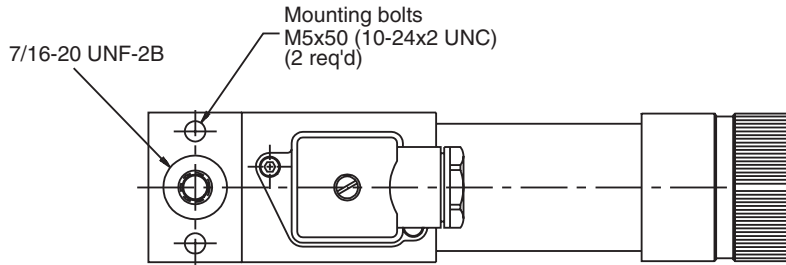

Mounting Pattern

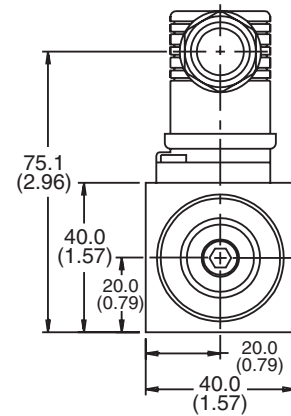
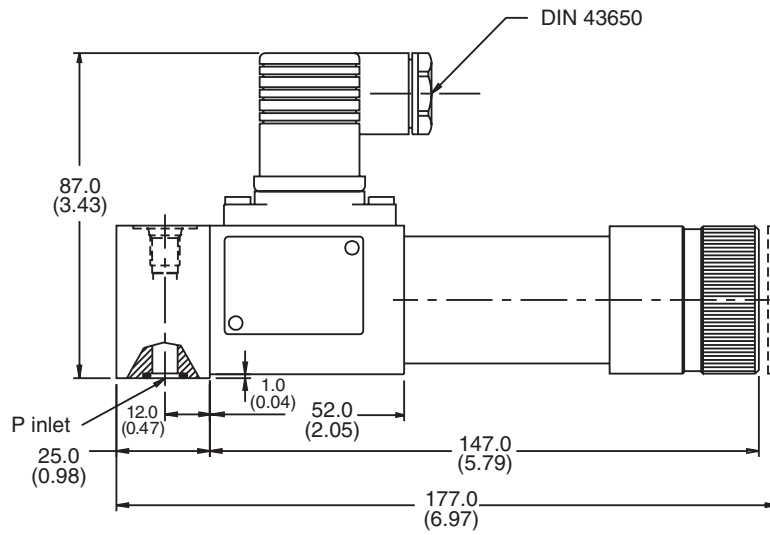
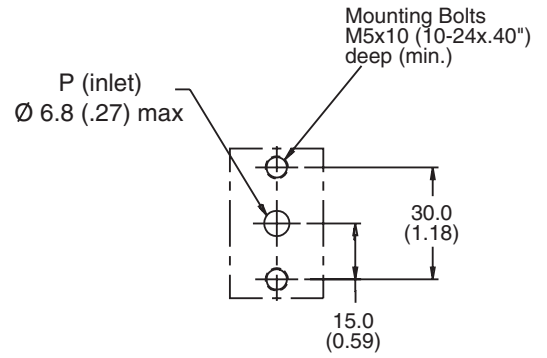

Inch equivalents for millimeter dimensions are shown in (**)

U2

