



aerospace  
climate control  
electromechanical  
filtration  
fluid & gas handling  
**hydraulics**  
pneumatics  
process control  
sealing & shielding



# Hydraulic Pump Division

Product Range - HY28-2673-01/HPD/US



ENGINEERING YOUR SUCCESS.



### **WARNING - USER RESPONSIBILITY**

**FAILURE OR IMPROPER SELECTION OR IMPROPER USE OF THE PRODUCTS DESCRIBED HEREIN OR RELATED ITEMS CAN CAUSE DEATH, PERSONAL INJURY AND PROPERTY DAMAGE.**

This document and other information from Parker-Hannifin Corporation, its subsidiaries and authorized distributors provide product or system options for further investigation by users having technical expertise.

The user, through its own analysis and testing, is solely responsible for making the final selection of the system and components and assuring that all performance, endurance, maintenance, safety and warning requirements of the application are met. The user must analyze all aspects of the application, follow applicable industry standards, and follow the information concerning the product in the current product catalog and in any other materials provided from Parker or its subsidiaries or authorized distributors.

To the extent that Parker or its subsidiaries or authorized distributors provide component or system options based upon data or specifications provided by the user, the user is responsible for determining that such data and specifications are suitable and sufficient for all applications and reasonably foreseeable uses of the components or systems.

### **OFFER OF SALE**

The items described in this document are hereby offered for sale by Parker-Hannifin Corporation, its subsidiaries or its authorized distributor. This offer and its acceptance are governed by the provisions stated in the detailed "Offer of Sale" elsewhere in this document.

© Copyright 2012, Parker Hannifin Corporation. All Rights Reserved.





<b>Introduction</b> .....	1-2
<b>Piston Pumps (Open Circuit &amp; Bent Axis)</b>	
(M) P1 Medium Pressure Mobile Piston Pumps .....	5-16
(I) PD Medium Pressure Industrial Piston Pumps.....	5-16
(M) P2 High Pressure/High Speed Mobile Piston Pumps .....	17-20
(M) P3 High Pressure/Super Charged Mobile Piston Pumps .....	21-24
(I) PVplus High Pressure Industrial Piston Pumps.....	25-30
(B) Premier Series High Pressure/Performance Piston Pumps.....	31-36
(M) VP1 Load Sensing Truck Pumps .....	37-40
(B) PAVC Medium Pressure/Super Charged Piston Pumps.....	41-44
(M) F11 Small Frame Fixed Displacement Bent-Axis Pumps/Motors .....	45-48
(M) F12 Large Frame Fixed Displacement Bent-Axis Pumps/Motors .....	49-52
(M) F1 Fixed Displacement Bent-Axis Truck Pumps/Motors .....	53-56
(M) F2 Twin Flow Bent-Axis Truck Pumps .....	57-60
(B) <b>Gold Cup Open &amp; Closed Circuit Pumps &amp; Motors for Hydrostatic Transmissions</b> .....	63-74
<b>Vane Pumps</b>	
(B) SDV 10/20 Medium Pressure Single Vane Pumps .....	77-80
(B) SDV2010 Medium Pressure Double Vane Pumps .....	81-84
(B) T7A Series High Performance Small Displacement Single Vane Pumps .....	85-86
(B) T6 Series Single, Double & Triple High Performance Vane Pumps .....	87-90
(B) T7 Series Single, Double & Triple High Performance Vane Pumps .....	91-93
(B) T67 High Performance Vane Pumps.....	94-96
(B) T6H/T7H Hybrid Technology Variable Piston Fixed Vane Pumps.....	97-100
<b>Motors</b>	
(M) F11 Small Frame Fixed Displacement Bent-Axis Pumps/Motors .....	103-106
(M) F12 Large Frame Fixed Displacement Bent-Axis Pumps/Motors .....	107-110
(M) F1 Fixed Displacement Bent-Axis Truck Pumps/Motors .....	111-112
(M) V12 Small Frame Variable Displacement Bent-Axis Motors .....	113-116
(M) V14 Large Frame Variable Displacement Bent-Axis Motors .....	117-120
(M) T12 Dual Displacement Bent-Axis Motors .....	121-124
(B) M3/M4 High Performance Vane Motors .....	125-127
(B) M5 High Performance Vane Motors .....	128-130
(B) MR-MRE Low Speed High Torque Small Displacement Radial Piston Motors .....	131-134
(B) MRT-MRTE-MRTF Low Speed High Torque Large Displacement Radial Piston Motors .....	131,135-137
(B) MRD-MRDE, MRV-MRVE Low Speed High Torque Variable Displacement Radial Piston Motors ..	131,138-140
(B) <b>Gold Cup Open &amp; Closed Circuit Pumps &amp; Motors for Hydrostatic Transmissions</b> .....	63-74
<b>Power Units</b>	
(I) D-Pak 5 Gallon.....	143-144
(I) H-Pak 10-40 Gallon, 0.9 - 6.3 GPM .....	145-152
(I) V-Pak 10-40 Gallon, 2 - 15.6 GPM.....	145-152
(I) V-Pak Low Profile 80 Gallon.....	145-152
<b>Reference</b>	
SAE Flanges and Shafts.....	155
Formulas and Conversions .....	156
Offer of Sale .....	157

(I) = Industrial (M) = Mobile (B) = both Industrial & Mobile



# Parker Hydraulic Pump Division: Continually Moving You Forward



The Hydraulic Pump Division (HPD) of Parker Hannifin Corporation is today's technology leader in the application, engineering and manufacture of piston and vane design hydraulic pumps and motors.

More than a superior-quality product supplier, Parker HPD is focused on performance that improves its customer's productivity and profitability. As a result, you're assured of highly reliable, durable designs that exceed requirements, as well as our leading technical capabilities, 24/7 accessibility and responsiveness, dependable on-time delivery and exceptional system support.

For applications ranging from medium-pressure to the most demanding on earth, Parker HPD provides product and system solutions to the world's mobile, industrial, mining and oil/gas markets. Our HPD centers are strategically located in Marysville, Ohio and Otsego, Michigan, where the industry's top teams design, engineer and manufacture HPD's lines as well as innovative solutions. Parker Hannifin, the world's largest motion and control company, supports the division's products with field sales, technical support, and distribution locations around the globe.

With leadership commitment, Parker HPD continually responds to customer and market requirements for greater speed, improved performance, more precise control, less noise and more flexibility. Many such results are evident in the following descriptions of Parker HPD's most in-demand products and innovations. For the performance advantages your systems need now, and in the changing environment ahead, look to the name you trust. The one in constant motion for your success: Parker's Hydraulic Pump Division.







## The Powerful Advantages of Parker HPD

- Technology Leadership for engineered solutions that exceed expectations
- Complete Product Lines
- Pumps – open and closed circuit, axial piston, bent axis and vane
- Pressures – medium, high, extreme
- Motors – fixed and variable; wide speed capability
- Power Units
- Custom Systems
- Added-Value Capabilities
- New-Product Development
- Customized Solutions
- Industry-Leading Lead Times
- 24/7 Access and Response
- Applications Team
- Industry-Leading Technical Support







# Piston Pumps

*Page*

**(M)** = Mobile **(I)** = Industrial **(B)** = Mobile & Industrial

<b>(M)</b>	<b>P1 Medium Pressure Mobile Piston Pumps</b>	<b>5-16</b>
<b>(I)</b>	<b>PD Medium Pressure Industrial Piston Pumps</b>	<b>5-16</b>
<b>(B)</b>	<b>P2 High Pressure/High Speed Piston Pumps</b>	<b>17-20</b>
<b>(M)</b>	<b>P3 High Pressure/Super Charged Mobile Piston Pumps</b>	<b>21-24</b>
<b>(I)</b>	<b>PVplus High Pressure Industrial Piston Pumps</b>	<b>25-30</b>
<b>(B)</b>	<b>Premier Series High Pressure/Performance Piston Pumps</b>	<b>31-36</b>
<b>(M)</b>	<b>VP1 Load Sensing Truck Pumps</b>	<b>37-40</b>
<b>(B)</b>	<b>PAVC Medium Pressure/Super Charged Piston Pumps</b>	<b>41-44</b>
<b>(M)</b>	<b>F11 Small Frame Fixed Displacement Bent-Axis Pumps/Motors</b>	<b>45-48</b>
<b>(M)</b>	<b>F12 Large Frame Fixed Displacement Bent-Axis Pumps/Motors</b>	<b>49-52</b>
<b>(M)</b>	<b>F1 Fixed Displacement Bent-Axis Truck Pumps/Motors</b>	<b>53-56</b>
<b>(M)</b>	<b>F2 Twin Flow Bent-Axis Truck Pumps</b>	<b>57-60</b>
<b>(B)</b>	<b>Gold Cup Open &amp; Closed Circuit Pumps &amp; Motors for Hydrostatic Transmissions</b>	<b>63-74</b>



ENGINEERING YOUR SUCCESS.

## P1/PD Medium Pressure Piston Pumps



P1



PD

- Variable displacement, axial piston pump for open-circuit applications
- Medium pressure, continuous operation at pressures up to 4060 PSI (280 BAR)
- Compact, quiet and efficient control
- Wide temperature range suitable for mobile applications

### P1 Mobile Pump Performance Data

Model Series	Displacement in <sup>3</sup> /rev (cc/rev)	Max. Outlet Pressure PSI (BAR)	Rated Drive Speed RPM	Flow GPM (LPM)	Input Horsepower HP (KW)
P1018	1.10 (18)	4000 (280)	3200	15 (56.8)	44 (32.8)
P1028	1.71 (28)	4000 (280)	3200	24 (90.8)	70 (52.2)
P1045	2.75 (45)	4000 (280)	2600	31 (117.3)	90 (67.1)
P1060	3.66 (60)	4000 (280)	2500	37 (140.1)	117 (87.2)
P1075	4.58 (75)	4000 (280)	2300	42 (159.0)	127 (94.7)
P1100	6.10 (100)	4000 (280)	2100	54 (204.4)	155 (115.6)
P1140	8.54 (140)	4000 (280)	2000	71 (268.8)	206 (153.6)

#### Markets

#### Applications

Forestry	Feller Bunchers, Knuckle Boom Loader, Skidder, Forwarder, Cranes
Oil & Gas	Nitrogen Pumps, Cementers, Coil Tubing
Construction	ADTs, Fan Drives
Mining	Drill Rigs, Top Drives, Loaders, Dump Trucks, Tunneling Equipment
Power Gen	Lube Oil Skids
Recycling	Shredders, Balers, Compactors, Vacuum Truck Systems, Refuse Trucks - ASL, Rear Loaders
Military	Fan Drives
Utility	Cranes, Digger Derricks, Man Lifts, Cable Placers, Fan Drives, Horizontal Directional Drills

### PD Industrial Pump Performance Data

Model Series	Displacement in <sup>3</sup> /rev (cc/rev)	Max. Outlet Pressure PSI (BAR)	Rated Drive Speed RPM	Flow GPM (LPM)	Input Horsepower HP (KW)
PD018	1.10 (18)	4000 (280)	1800	8 (30.3)	23 (17.2)
PD028	1.71 (28)	4000 (280)	1800	13 (49.2)	33 (24.6)
PD045	2.75 (45)	4000 (280)	1800	21 (79.5)	53 (39.5)
PD060	3.66 (60)	4000 (280)	1800	27 (102.2)	79 (58.9)
PD075	4.58 (75)	4000 (280)	1800	34 (128.7)	100 (74.6)
PD100	6.10 (100)	4000 (280)	1800	46 (174.1)	133 (99.2)
PD140	8.54 (140)	4000 (280)	1800	63 (238.5)	185 (138.0)

#### Markets

#### Applications

Industrial	Power Units, Industrial Molding, Press
Oil & Gas	Oil Lift Pumps
Power Gen	Turbine Start
Material Handling	Conveyor Drives





# Piston Pumps (Mobile or Industrial)

## P1/PD Medium Pressure Mobile Piston Pumps

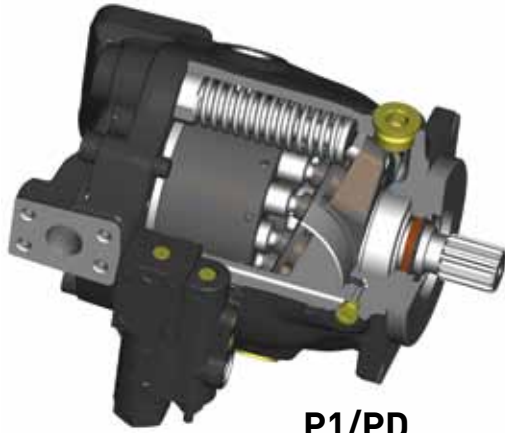

P1/PD

### Benefits/Features

- Compact overall package size
- Quiet operation
- Low flow ripple to further reduce noise
- Elastomer seals that eliminate gaskets and external leakage
- High operating efficiency for lower power consumption and reduced heat generation
- Simple hydraulic controls with “no-leak” adjustments
- SAE and ISO standard mounting flanges and ports
- Long life, tapered-roller shaft bearings
- Long life, low friction, hydrostatically balanced cam bearings
- Full power through-drive capability
- End or side inlet and outlet ports
- Case drain ports for horizontal or vertical, shaft-up mounting
- Optional minimum and maximum displacement adjustments
- Optional case-to-inlet check valve to extend shaft seal life
- Easy to service

## P1 Medium Pressure Mobile Piston Pumps

### Performance Characteristics

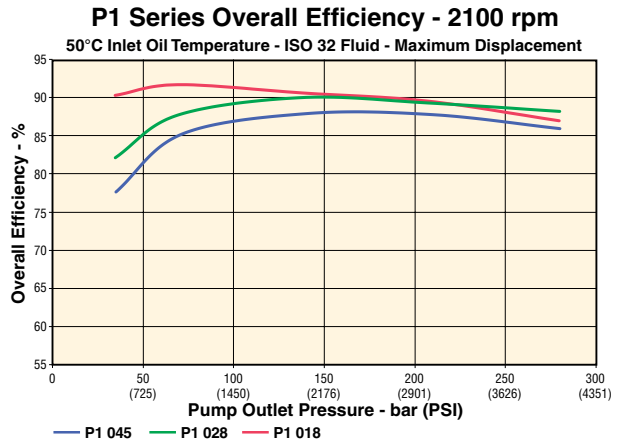
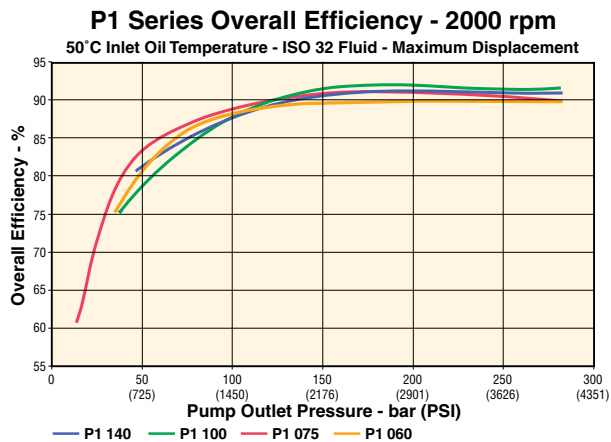
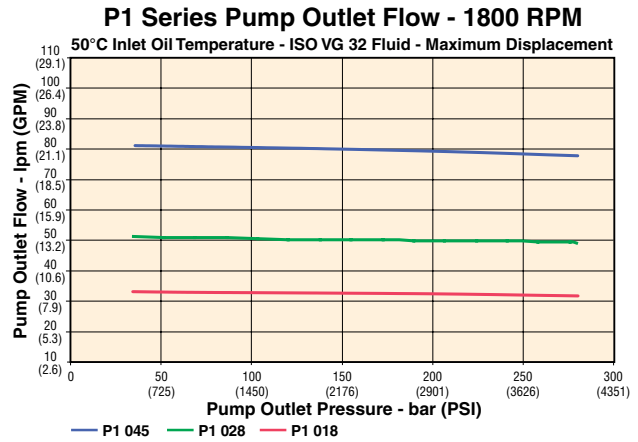
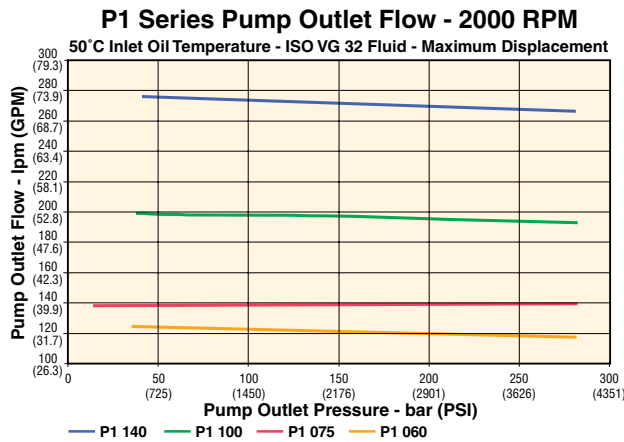
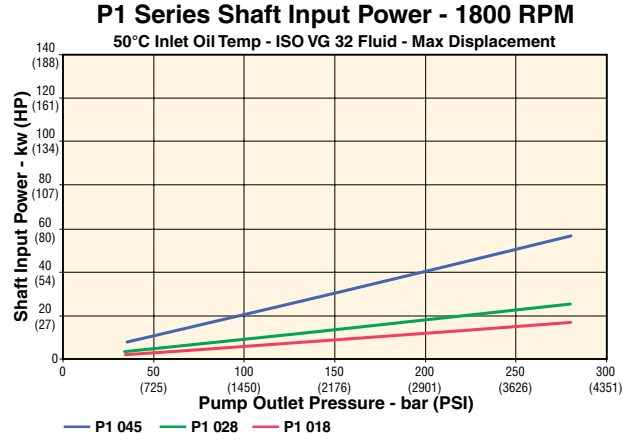
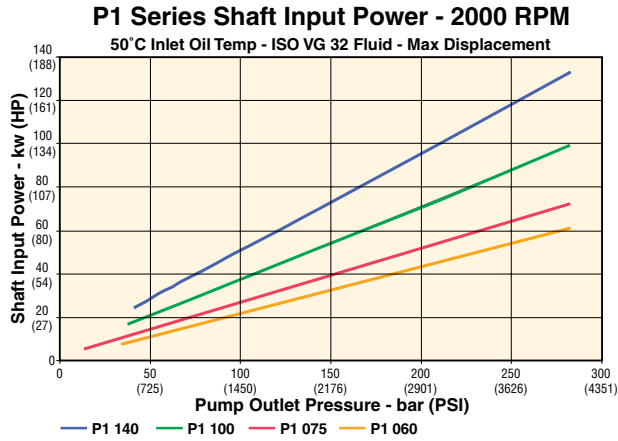



# Piston Pumps (Industrial)

## PD Medium Pressure Industrial Piston Pumps

### Performance Characteristics

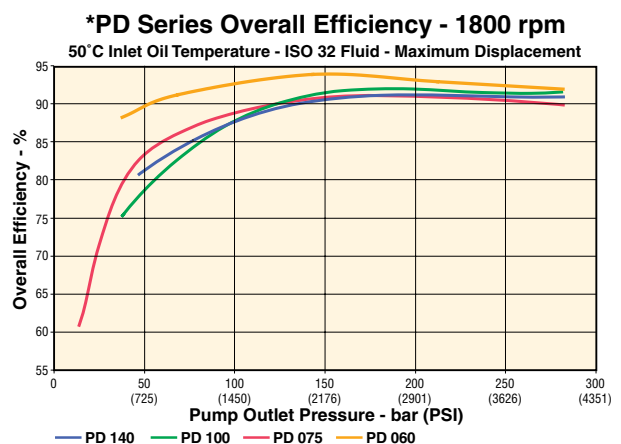
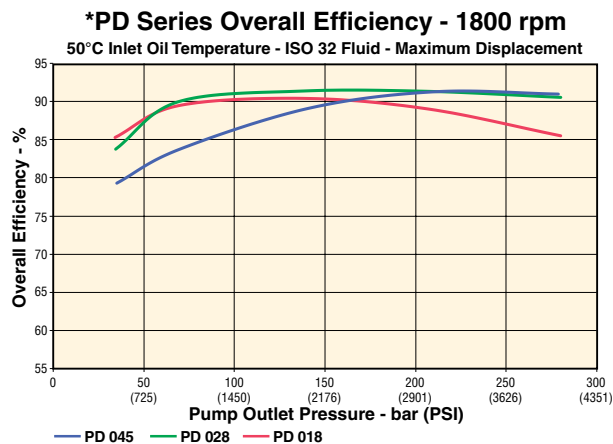
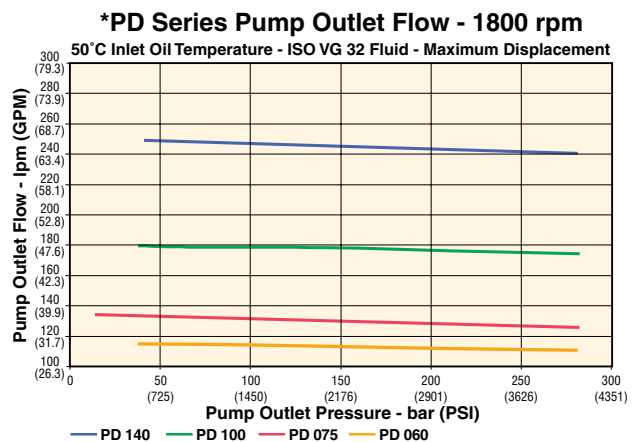
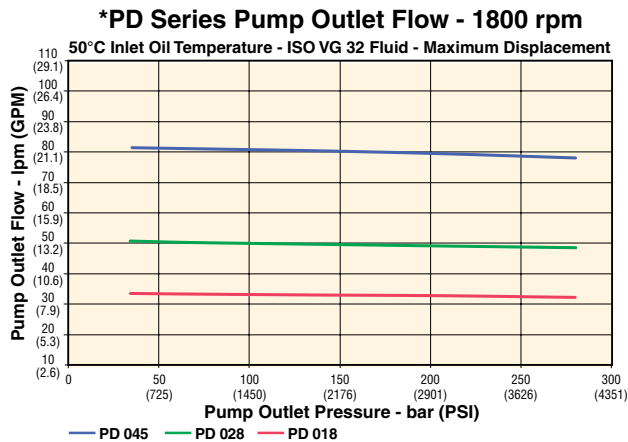
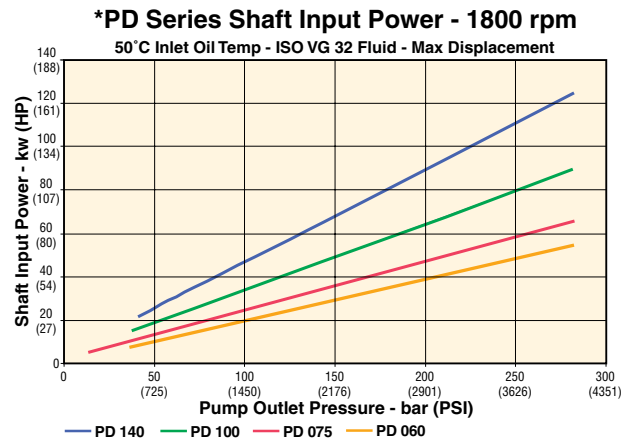
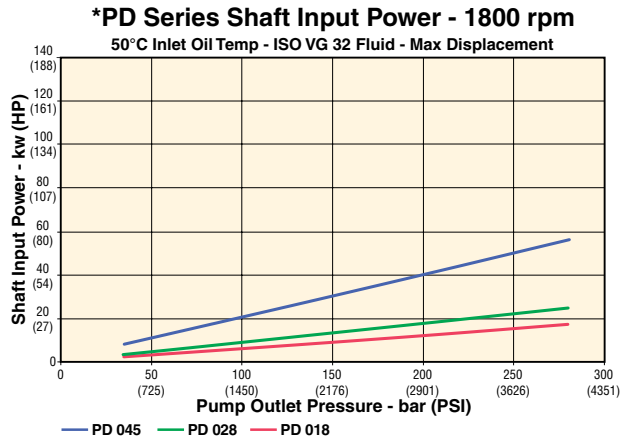

\* For additional speeds, see enclosed CD

## P1/PD Medium Pressure Mobile Piston Pumps

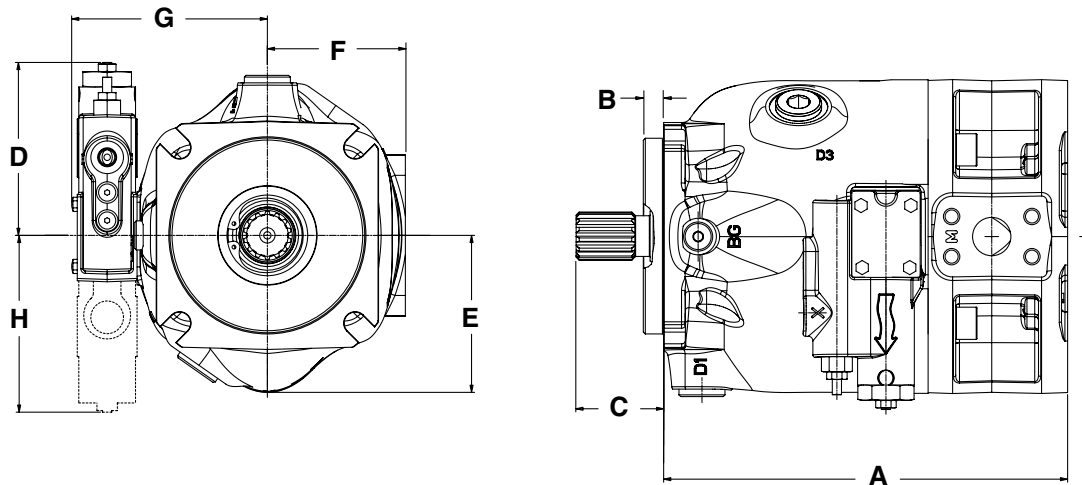

### Dimensions, inch (mm)

Series	A	B	C Max.	D	E	F	G	H Max.
P1/PD018	6.46 (164.2)	0.24 (6.2)	1.29 (32.8)	4.72 (120)	2.97 (75.5)	2.60 (66)	4.24 (107.7)	4.80 (122)
P1/PD028	9.25 (235.5)	0.37 (9.5)	1.84 (46.8)	4.72 (120)	3.21 (81.5)	2.93 (74.5)	4.48 (113.8)	4.80 (122)
P1/PD045	9.00 (228.7)	0.37 (9.5)	1.84 (46.8)	4.72 (120)	3.63 (92.3)	2.92 (74.2)	4.75 (120.7)	4.80 (122)
P1/PD060	9.96 (253.0)	0.50 (12.7)	2.24 (56.8)	4.72 (120)	3.98 (101.2)	3.23 (82)	4.88 (123.9)	4.80 (122)
P1/PD075	10.37 (263.5)	0.50 (12.7)	2.24 (56.8)	4.72 (120)	4.09 (103.8)	3.54 (90)	5.03 (127.7)	4.80 (122)
P1/PD100	13.37 (339.6)	0.50 (12.7)	2.47 (62.8)	4.72 (120)	4.61 (117.1)	3.98 (101)	5.66 (143.7)	4.80 (122)
P1/PD140	14.34 (364.3)	0.50 (12.7)	2.97 (75.5)	4.72 (120)	5.24 (133)	4.45 (113)	6.13 (155.7)	4.80 (122)

### SAE Flanges & Shafts

	PD018	PD028, PD045	PD060, PD075	PD100	PD140
Mounting flange, SAE	82-2 (A)	101-2 (B)	127-4 (C)	127-4 (C)	152-4 (D)
Pilot diameter, in (mm)	3.2 (82.5)	4.0 (101.6)	5.0 (127)	5.0 (127)	6.0 (152.4)
Keyed shaft, SAE	19-1 (A)	25-1 (B-B)	32-1 (C)	38-1 (C-C)	44-1 (D)
Spline shaft, SAE	11T-16/32P	15T-16/32P (B-B)	14T-12/24P (C)	17T-12/24P (C-C)	13T-8/16P (D)





# Piston Pumps

## P1/PD 18cc, Model Ordering Code

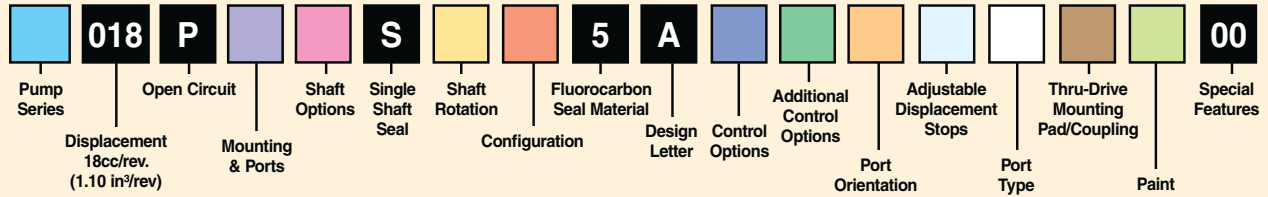

Pump Series	
P1	Mobile
PD	Industrial

Mounting & Ports	
S	SAE A Pilot SAE Threaded Work Ports with SAE Aux Ports
A	SAE A Pilot Metric Work Ports with BSPP Aux Ports
M	ISO - 80mm Pilot Metric Work Ports with Metric Aux Ports
B	ISO - 80mm Pilot Metric Work Ports with BSPP Aux Ports

Shaft Options	
01	Splined shaft - SAE 19-4 11T
02	Keyed shaft - SAE 19-1 .75" Dia.
04	ISO keyed 20MM Dia.
06	Splined shaft - SAE A 9T*

\*Not available with Thru-Drive

Shaft Rotation	
R	Clockwise
L	Counterclockwise

Configuration	
M	Mobile (P1)
S	Industrial (PD)

Control Options	
C0	Pressure limiter 1160.30 - 4061.05 PSI (80 - 280 bar)
C1	Pressure limiter 290.08 - 1160.30 PSI (20 - 80 bar)
L0	Load sensing 145.04-435.11 PSI ΔP (10-30 bar ΔP) with pressure limiter 1160.30 - 4061.05 PSI (80 - 280 bar)
L2	Load sensing 145.04-435.11 PSI ΔP (10-30 bar ΔP) with bleed & pressure limiter 1160.30 - 4061.05 PSI (80 - 280 bar)
AN*	Pilot operated pressure limiter with ISO4401 interface & SAE 4 Vent Port
AM	Pilot operated pressure limiter with mechanical adjustment and SAE 4 Vent Port
AE	Pilot operated pressure limiter with mechanical and electrical adjustment 12 VDC
AF	Pilot operated pressure limiter with mechanical and electrical adjustment 24 VDC
##	See chart below for electronic control options

\*Not functional control as such

Additional Control Options	
0	No other options
2	Displacement sensor **

\*\* mandatory with "W\*\*\*", "X\*\*\*", "Y\*\*\*", "Z\*\*\*" "D\*" and "Y\*"

Port Orientation	
E	End Ports
R	Side ported with ripple chamber
T	Side ported with Thru-Drive

Adjustable Displacement Stops	
0	None
1	Adjustable maximum displacement stop
2	Adjustable minimum displacement stop
3	Adjustable maximum and minimum displacement stop

Port Type	
0	Flange Ports*
2	Threaded Ports

\*With Thru-Drive Only

Thru-Drive Mounting Pad/Coupling	
0	No Thru-Drive
A	SAE 82-2(A), 16(A), 9T coupling
H	SAE 82-2(A), 19(--), 11T coupling

Paint	
00	No Paint
PB	Black Paint

Electronic Control Options	
#	#

0	No ECU
D	Proportional displacement control
Y	Proportional pressure and displacement control

P	Electronic valve with zero displacement default
T	Electronic valve with max displacement default
S	Electronic valve with zero displacement default and hydromechanical Pmax
U	Electronic valve with max displacement default and hydromechanical Pmax
W	Electronic valve with zero displacement default (CANBUS compatible)
X	Electronic valve with max displacement default (CANBUS compatible)
Y	Electronic valve with zero displacement default and hydromechanical Pmax (CANBUS compatible)
Z	Electronic valve with max displacement default and hydromechanical Pmax (CANBUS compatible)

\*\*\* W, X, Y and Z only available with "D\*" and "Y\*"

# Piston Pumps

## P1/PD 28cc, Model Ordering Code

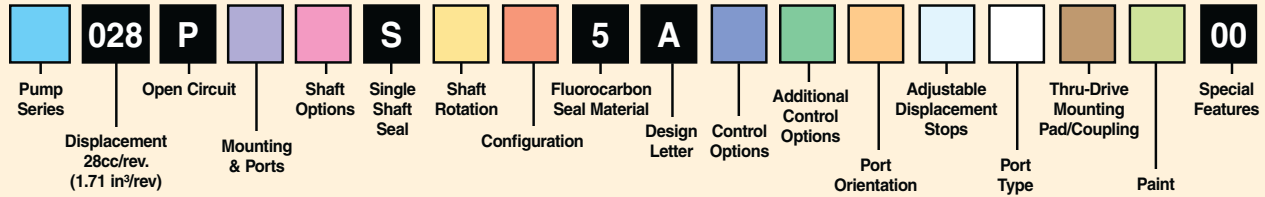

Pump Series	
P1	Mobile
PD	Industrial

Mounting & Ports	
S	SAE B Pilot SAE Work Ports with SAE Aux Ports
A	SAE B Pilot Metric Work Ports with BSPP Aux Ports
M	ISO - 100MM Pilot Metric Work Ports with Aux Ports
B	ISO - 100MM Pilot Metric Work Ports with BSPP Aux Ports

Shaft Options	
01	Splined shaft - SAE B-B 15T
02	Keyed shaft - SAE B-B 1" Dia.
04	ISO keyed 25MM Dia.
08	Splined shaft - SAE B 13T

Shaft Rotation	
R	Clockwise
L	Counterclockwise

Configuration	
M	Mobile (P1)
S	Industrial (PD)

Control Options	
C0	Pressure limiter 1160.30 - 4061.05 PSI (80 - 280 bar)
C1	Pressure limiter 290.08 - 1160.30 PSI (20 - 80 bar)
L0	Load sensing 145.04-435.11 PSI ΔP (10-30 bar ΔP) with pressure limiter 1160.30 - 4061.05 PSI (80 - 280 bar)
L2	Load sensing 145.04-435.11 PSI ΔP (10-30 bar ΔP) with bleed & pressure limiter 1160.30 - 4061.05 PSI (80 - 280 bar)
AN*	Pilot operated pressure limiter with ISO4401 interface & SAE 4 Vent Port
AM	Pilot operated pressure limiter with mechanical adjustment and SAE 4 Vent Port
AE	Pilot operated pressure limiter with mechanical and electrical adjustment 12 VDC
AF	Pilot operated pressure limiter with mechanical and electrical adjustment 24 VDC
##	See chart below for electronic control options

\*Not functional control as such

Additional Control Options	
0	No other options
2	Displacement sensor **

\*\* mandatory with "W\*\*\*", "X\*\*\*", "Y\*\*\*", "Z\*\*\*" "D\*" and "Y\*"

Port Orientation	
E	End Ports
R	Side ported with ripple chamber
T	Side ported with through drive

Adjustable Displacement Stops* (For E & R Port Orientation Only)	
0	None
1	Adjustable maximum displacement stop
2	Adjustable minimum displacement stop
3	Adjustable maximum and minimum displacement stop

\*Not available with Thru-Drive

Port Type	
0	Flange Ports
2	Threaded Ports

Thru-Drive Mounting Pad/Coupling	
0	No Thru-Drive
A	SAE 82-2 (A), 16 (A), 9T coupling
H	SAE 82-2 (A), 19 (-), 11T coupling
B	SAE 101-2 (B), 22 (B) , 13T coupling
Q	SAE 101-2 (B), 25 (B-B), 15T coupling

Paint	
00	No Paint
PB	Black Paint

Electronic Control Options	
#	#

0	No ECU
D	Proportional displacement control
Y	Proportional pressure and displacement control

P	Electronic valve with zero displacement default
T	Electronic valve with max displacement default
S	Electronic valve with zero displacement default and hydromechanical Pmax
U	Electronic valve with max displacement default and hydromechanical Pmax
W	Electronic valve with zero displacement default (CANBUS compatible)
X	Electronic valve with max displacement default (CANBUS compatible)
Y	Electronic valve with zero displacement default and hydromechanical Pmax (CANBUS compatible)
Z	Electronic valve with max displacement default and hydromechanical Pmax (CANBUS compatible)

\*\*\* W, X, Y and Z only available with "D\*" and "Y\*"



# Piston Pumps

## P1/PD 45cc, Model Ordering Code

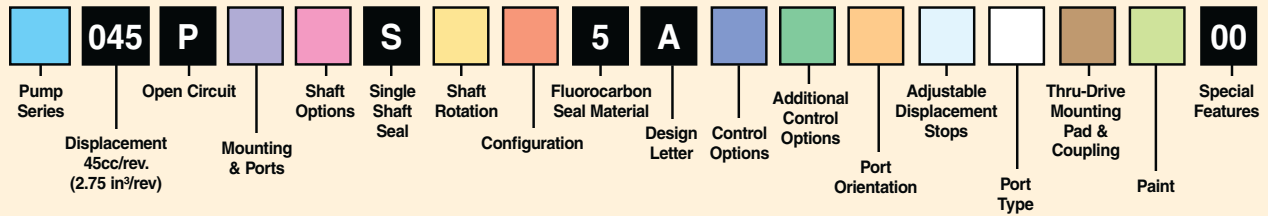

Pump Series	
P1	Mobile
PD	Industrial

Mounting & Ports	
S	SAE B Pilot with SAE Threaded or Flange Work Ports with SAE Aux Ports
A	SAE B Pilot with Metric Threaded or Metric Flange Work Ports with BSPP Aux Ports
M	ISO - 100MM Pilot Metric Threaded or Metric Flange Work Ports with Aux Ports
B	ISO - 100MM Pilot Metric Threaded or Metric Flange Work Ports with Aux Ports

Shaft Options	
01	Splined shaft - SAE B-B 15T
02	Keyed shaft - SAE B-B 1" Dia.
04	ISO keyed 25MM Dia.
08	Splined shaft - SAE B 13T

Shaft Rotation	
R	Clockwise
L	Counterclockwise

Configuration	
M	Mobile (P1)
S	Industrial (PD)
U	Universal (SAE Mounting Option, S, Only)

Control Options	
C0	Pressure limiter 1160.30 - 4061.05 PSI (80 - 280 bar)
C1	Pressure limiter 290.08 - 1160.30 PSI (20 - 80 bar)
L0	Load sensing 145.04-435.11 PSI ΔP (10-30 bar ΔP) with pressure limiter 1160.30 - 4061.05 PSI (80 - 280 bar)
L2	Load sensing 145.04-435.11 PSI ΔP (10-30 bar ΔP) with bleed & pressure limiter 1160.30 - 4061.05 PSI (80 - 280 bar)
AN*	Pilot operated pressure limiter with ISO4401 interface & SAE 4 Vent Port
AL	Pilot operated pressure limiter with Load sensing (only available with "T" Torque Limiter option, i.e. "ALT ")
AM	Pilot operated pressure limiter with mechanical adjustment and SAE 4 Vent Port
AE	Pilot operated pressure limiter with mechanical and electrical adjustment 12 VDC
AF	Pilot operated pressure limiter with mechanical and electrical adjustment 24 VDC
##	See chart below for electronic control options

\*Not functional control as such

Additional Control Options	
0	No other options
2	Displacement sensor **
T	Torque Limiter Control (Used with AM, AN or AL control options)

\*\* mandatory with "W\*\*\*", "X\*\*\*", "Y\*\*\*", "Z\*\*\*" "D\*" and "Y\*"

Port Orientation	
E	End Ports
R	Side ported with ripple chamber
T	Side ported with through drive

Adjustable Displacement Stops* (For E & R Port Orientation Only)	
0	None
1	Adjustable maximum displacement stop
2	Adjustable minimum displacement stop
3	Adjustable maximum and minimum displacement stop

\*Not available with Thru-Drive

Port Type	
0	Flange Ports
2	Threaded Ports

Thru-Drive Mounting Pad/Coupling	
0	No Thru-Drive
A	SAE 82-2 (A), 16 (A), 9T coupling
H	SAE 82-2 (A), 19 (-), 11T coupling
B	SAE 101-2 (B), 22 (B), 13T coupling
Q	SAE 101-2 (B), 25 (B-B), 15T coupling

Paint	
00	No Paint
PB	Black Paint

Electronic Control Options	
#	#

0	No ECU
D	Proportional displacement control
Y	Proportional pressure and displacement control

P	Electronic valve with zero displacement default
T	Electronic valve with max displacement default
S	Electronic valve with zero displacement default and hydromechanical Pmax
U	Electronic valve with max displacement default and hydromechanical Pmax
W	Electronic valve with zero displacement default (CANBUS compatible)
Y	Electronic valve with max displacement default (CANBUS compatible)
X	Electronic valve with zero displacement default and hydromechanical Pmax (CANBUS compatible)
Z	Electronic valve with max displacement default and hydromechanical Pmax (CANBUS compatible)

\*\*\* W, X, Y and Z only available with "D\*" and "Y\*"

# Piston Pumps

## P1/PD 60cc, Model Ordering Code

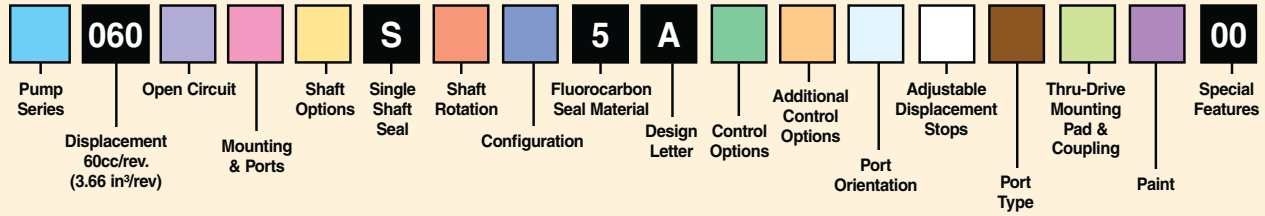

Pump Series	
P1	Mobile
PD	Industrial

Open Circuit	
P	Open Circuit (One Side of Center)
X	Open Circuit (100% over Center)

Mounting & Ports	
S	SAE C Pilot SAE Flange Connection Ports with SAE Aux Ports
A	SAE C Pilot Metric Flange Connection Ports with BSPP Aux Ports
M	ISO - 125MM Pilot Metric Flange Connection Ports with Metric Aux Ports
B	ISO - 125MM Pilot, Metric Flange Connection Ports with BSPP Aux Ports
C	SAE C 2-Bolt Pilot SAE Flange Connection Ports with SAE Aux Ports
D	SAE C 2-Bolt Pilot SAE Flange Connection Ports with BSPP Aux Ports

Shaft Options	
01	Spined shaft - SAE C 14T
02	Keyed shaft - SAE C 32-1 KEY
04	Keyed shaft - ISO / DIN KEY 32MM Dia.

Shaft Rotation	
R	Clockwise
L	Counterclockwise

Configuration	
M	Mobile (P1)
S	Industrial (PD)
U	Universal

Control Options	
C0	Pressure limiter 1160.30 - 4061.05 PSI (80 - 280 bar)
C1	Pressure limiter 290.08 - 1160.30 PSI (20 - 80 bar)
L0	Load sensing 145.04-435.11 PSI ΔP (10-30 bar ΔP) with pressure limiter 1160.30 - 4061.05 PSI (80 - 280 bar)
L2	Load sensing 145.04-435.11 PSI ΔP (10-30 bar ΔP) with bleed & pressure limiter 1160.30 - 4061.05 PSI (80 - 280 bar)
AN*	Pilot operated pressure limiter with ISO4401 interface & SAE 4 Vent Port
AL	Pilot operated pressure limiter with Load sensing ( only available with "T" Torque Limiter option, i.e. "ALT ")
AM	Pilot operated pressure limiter with mechanical adjustment and SAE 4 Vent Port
AE	Pilot operated pressure limiter with mechanical and electrical adjustment 12 VDC
AF	Pilot operated pressure limiter with mechanical and electrical adjustment 24 VDC
##	See chart below for electronic control options

\*Not functional control as such

Additional Control Options	
0	No other options
2	Displacement sensor **
T	Torque Limiter Control (Used with AM, AN or AL control options)

\*\* mandatory with "W\*\*\*", "X\*\*\*", "Y\*\*\*", "Z\*\*\*" "D" and "Y"

Port Orientation	
E	End Ports
S	Side Ports
T	Side Ports with Thru-Drive

Adjustable Displacement Stops* (For E & S Port Orientation Only)	
0	None
1	Adjustable maximum displacement stop
2	Adjustable minimum displacement stop
3	Adjustable maximum and minimum displacement stop

\*Not available with Thru-Drive

Port Type	
0	Flange Ports
2	SAE Threaded Ports (Available only on "E" port and "S" or "C" mount)
4	BSPP Threaded Ports (Available only on "E" port and "D" mount)

Thru-Drive Mounting Pad/Coupling	
0	No Thru-Drive
A	SAE 82-2 (A), 16 (A), 9T coupling
H	SAE 82-2 (A), 19 (-), 11T coupling
B	SAE 101-2 (B), 22 (B), 13T coupling
Q	SAE 101-2 (B), 25 (B-B), 15T coupling
J	SAE 101-2 (B), rotated 45 degrees, 22 (B), 13T coupling
K	SAE 101-2 (B), rotated 45 degrees, 25 (B-B), 15T coupling
C	SAE 127-4 (C), 32 (C), 14T coupling

Paint	
00	No Paint
PB	Black Paint

Electronic Control Options	
#	#

0	No ECU
D	Proportional displacement control
Y	Proportional pressure control

P	Electronic valve with zero displacement default
T	Electronic valve with max displacement default
S	Electronic valve with zero displacement default and hydromechanical Pmax
U	Electronic valve with max displacement default and hydromechanical Pmax
W	Electronic valve with zero displacement default (CANBUS compatible)
Y	Electronic valve with max displacement default (CANBUS compatible)
X	Electronic valve with zero displacement default and hydromechanical Pmax (CANBUS compatible)
Z	Electronic valve with max displacement default and hydromechanical Pmax (CANBUS compatible)

\*\*\* W, X, Y and Z only available with "D" and "Y"





# Piston Pumps

## P1/PD 75cc, Model Ordering Code

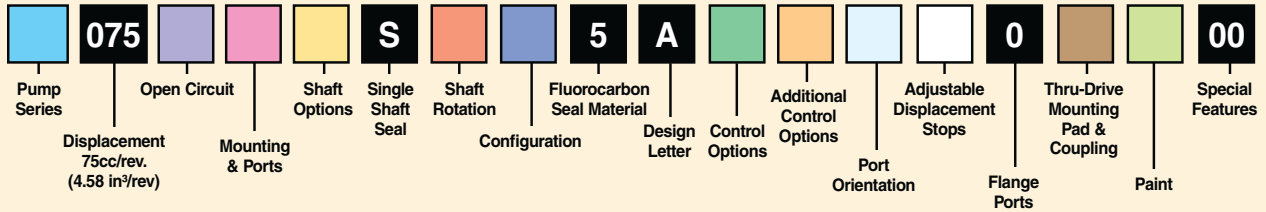

Pump Series	
P1	Mobile
PD	Industrial

Open Circuit	
P	Open Circuit (One Side of Center)
X	Open Circuit (100% over Center)

Mounting & Ports	
S	SAE C Pilot SAE Flange Connection Ports with SAE Aux Ports
A	SAE C Pilot Metric Flange Connection Ports with BSPP Aux Ports
M	ISO - 125MM Pilot Metric Flange Connection Ports with Metric Aux Ports
B	ISO - 125MM Pilot, Metric Flange Connection Ports with BSPP Aux Ports
C	SAE C 2-Bolt Pilot SAE Flange Connection Ports with SAE Aux Ports
D	SAE C 2-Bolt Pilot SAE Flange Connection Ports with BSPP Aux Ports

Shaft Options	
01	Spined shaft - SAE C 14T
02	Keyed shaft - SAE C 32-1 KEY
04	Keyed shaft - ISO / DIN KEY 32MM Dia.

Shaft Rotation	
R	Clockwise
L	Counterclockwise

Configuration	
M	Mobile (P1)
S	Industrial (PD)
U	Universal

Control Options	
C0	Pressure limiter 1160.30 - 4061.05 PSI (80 - 280 bar)
C1	Pressure limiter 290.08 - 1160.30 PSI (20 - 80 bar)
L0	Load sensing 145.04-435.11 PSI ΔP (10-30 bar ΔP) with pressure limiter 1160.30 - 4061.05 PSI (80 - 280 bar)
L2	Load sensing 145.04-435.11 PSI ΔP (10-30 bar ΔP) with bleed & pressure limiter 1160.30 - 4061.05 PSI (80 - 280 bar)
AN*	Pilot operated pressure limiter with ISO4401 interface & SAE 4 Vent Port
AM	Pilot operated pressure limiter with mechanical adjustment and SAE 4 Vent Port
AE	Pilot operated pressure limiter with mechanical and electrical adjustment 12 VDC
AF	Pilot operated pressure limiter with mechanical and electrical adjustment 24 VDC
##	See chart below for electronic control options

\*Not functional control as such

Additional Control Options	
0	No other options
2	Displacement sensor **
T	Torque Limiter Control (Used with AM, AN or L0 control options)

\*\* mandatory with "W\*\*\*", "X\*\*\*", "Y\*\*\*", "Z\*\*\*" "D\*" and "Y\*\*"

Port Orientation	
E	End Ports
S	Side Ports
T	Side Ports with Thru-Drive

Adjustable Displacement Stops* (For E & S Port Orientation Only)	
0	None
1	Adjustable maximum displacement stop
2	Adjustable minimum displacement stop
3	Adjustable maximum and minimum displacement stop

\*Not available with Thru-Drive

Thru-Drive Mounting Pad/Coupling	
0	No Thru-Drive
A	SAE 82-2 (A), 16 (A), 9T coupling
H	SAE 82-2 (A), 19 (--), 11T coupling
B	SAE 101-2 (B), 22 (B), 13T coupling
Q	SAE 101-2 (B), 25 (B-B), 15T coupling
J	SAE 101-2 (B), rotated 45 degrees, 22 (B), 13T coupling
K	SAE 101-2 (B), rotated 45 degrees, 25 (B-B), 15T coupling
C	SAE 127-4 (C), 32 (C), 14T coupling

Paint	
00	No Paint
PB	Black Paint

Electronic Control Options	
#	#

0	No ECU
D	Proportional displacement control
Y	Proportional pressure control

P	Electronic valve with zero displacement default
T	Electronic valve with max displacement default
S	Electronic valve with zero displacement default and hydromechanical Pmax
U	Electronic valve with max displacement default and hydromechanical Pmax
W	Electronic valve with zero displacement default (CANBUS compatible)
Y	Electronic valve with max displacement default (CANBUS compatible)
X	Electronic valve with zero displacement default and hydromechanical Pmax (CANBUS compatible)
Z	Electronic valve with max displacement default and hydromechanical Pmax (CANBUS compatible)

\*\*\* W, X, Y and Z only available with "D\*" and "Y\*\*"

# Piston Pumps

## P1/PD 100cc, Model Ordering Code

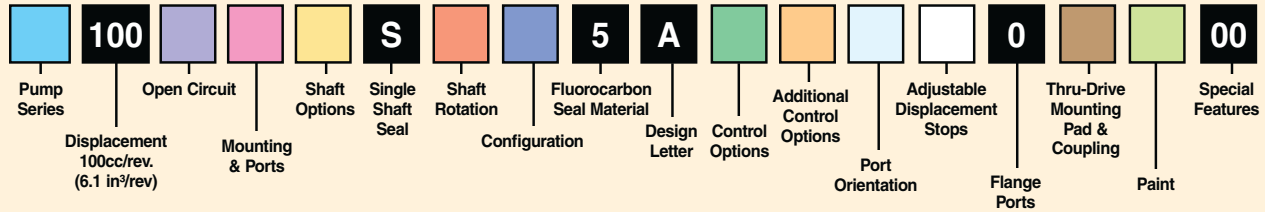

Pump Series	
P1	Mobile
PD	Industrial

Open Circuit	
P	Open Circuit (One Side of Center)
X	Open Circuit (100% over Center)

Mounting & Ports	
S	SAE C Pilot SAE Flange Connection Ports with SAE Aux Ports
A	SAE C Pilot Metric Flange Connection Ports with BSPP Aux Ports
M	ISO - 125MM Pilot Metric Flange Connection Ports with Metric Aux Ports
B	ISO - 125MM Pilot, Metric Flange Connection Ports with BSPP Aux Ports

Shaft Options	
01	Splined shaft - SAE C-C 17T
02	Keyed shaft - SAE C-C 38-1
04	Keyed shaft - ISO / DIN 40MM Dia.
06	Splined shaft - SAE C 14T

Shaft Rotation	
R	Clockwise
L	Counterclockwise

Configuration	
M	Mobile (P1)
S	Industrial (PD)
U	Universal

Control Options	
C0	Pressure limiter 1160.30 - 4061.05 PSI (80 - 280 bar)
C1	Pressure limiter 290.08 - 1160.30 PSI (20 - 80 bar)
L0	Load sensing 145.04-435.11 PSI ΔP (10-30 bar ΔP) with pressure limiter 1160.30 - 4061.05 PSI (80 - 280 bar)
L2	Load sensing 145.04-435.11 PSI ΔP (10-30 bar ΔP) with bleed & pressure limiter 1160.30 - 4061.05 PSI (80 - 280 bar)
AN*	Pilot operated pressure limiter with ISO4401 interface & SAE 4 Vent Port
AM	Pilot operated pressure limiter with mechanical adjustment and SAE 4 Vent Port
AE	Pilot operated pressure limiter with mechanical and electrical adjustment 12 VDC
AF	Pilot operated pressure limiter with mechanical and electrical adjustment 24 VDC
##	See chart below for electronic control options

\*Not functional control as such

Additional Control Options	
0	No other options
2	Displacement sensor **
T	Torque Limiter Control (Used with AM, AN or L0 control options)

\*\* mandatory with "W\*\*\*", "X\*\*\*", "Y\*\*\*", "Z\*\*\*" "D\*" and "Y\*\*"

Port Orientation	
E	End Ports
S	Side Ports
T	Side Ports with Thru-Drive

Adjustable Displacement Stops* (For E & S Port Orientation Only)	
0	None
1	Adjustable maximum displacement stop
2	Adjustable minimum displacement stop
3	Adjustable maximum and minimum displacement stop

\*Not available with Thru-Drive

Thru-Drive Mounting Pad/Coupling	
0	No Thru-Drive
A	SAE 82-2 (A), 16 (A), 9T coupling
H	SAE 82-2 (A), 19 (-), 11T coupling
B	SAE 101-2 (B), 22 (B), 13T coupling
Q	SAE 101-2 (B), 25 (B-B), 15T coupling
J	SAE 101-2 (B), rotated 45 degrees, 22 (B), 13T coupling
K	SAE 101-2 (B), rotated 45 degrees, 25 (B-B), 15T coupling
C	SAE 127-4 (C), 32 (C), 14T coupling
N	SAE 127-4 (C), 38 (C-C), 17T coupling

Paint	
00	No Paint
PB	Black Paint

Electronic Control Options	
#	#

0	No ECU
D	Proportional displacement control
Y	Proportional pressure control

P	Electronic valve with zero displacement default
T	Electronic valve with max displacement default
S	Electronic valve with zero displacement default and hydromechanical Pmax
U	Electronic valve with max displacement default and hydromechanical Pmax
W	Electronic valve with zero displacement default (CANBUS compatible)
Y	Electronic valve with max displacement default (CANBUS compatible)
X	Electronic valve with zero displacement default and hydromechanical Pmax (CANBUS compatible)
Z	Electronic valve with max displacement default and hydromechanical Pmax (CANBUS compatible)

\*\*\* W, X, Y and Z only available with "D\*" and "Y\*\*"



# Piston Pumps

## P1/PD 140cc, Model Ordering Code

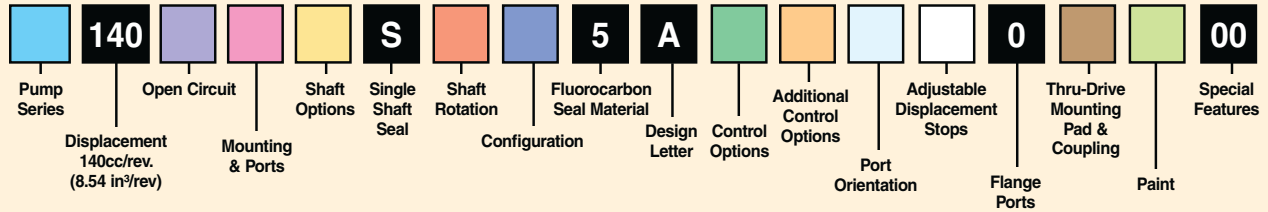

Pump Series	
P1	Mobile
PD	Industrial

Open Circuit	
P	Open Circuit (One Side of Center)
X	Open Circuit (100% over Center)

Mounting & Ports	
S	SAE D Pilot SAE Flange Connection Ports with SAE Aux Ports
A	SAE D Pilot BSPP Flange Connection Ports with BSPP Aux Ports
M	ISO - 180MM Pilot Metric Flange Connection Ports with Metric Aux Ports
B	ISO - 180MM Pilot Metric Flange Connection Ports with BSPP Aux Ports

Shaft Options	
01	Splined shaft - SAE D 13T
02	Keyed shaft - SAE D 44-1
04	Keyed shaft - ISO / DIN 50MM Dia.

Shaft Rotation	
R	Clockwise
L	Counterclockwise

Configuration	
M	Mobile (P1)
S	Industrial (PD)
U	Universal

Control Options	
C0	Pressure limiter 1160.30 - 4061.05 PSI (80 - 280 bar)
C1	Pressure limiter 290.08 - 1160.30 PSI (20 - 80 bar)
L0	Load sensing 145.04-435.11 PSI ΔP (10-30 bar ΔP) with pressure limiter 1160.30 - 4061.05 PSI (80 - 280 bar)
L2	Load sensing 145.04-435.11 PSI ΔP (10-30 bar ΔP) with bleed & pressure limiter 1160.30 - 4061.05 PSI (80 - 280 bar)
AN*	Pilot operated pressure limiter with ISO4401 interface & SAE 4 Vent Port
AM	Pilot operated pressure limiter with mechanical adjustment and SAE 4 Vent Port
AE	Pilot operated pressure limiter with mechanical and electrical adjustment 12 VDC
AF	Pilot operated pressure limiter with mechanical and electrical adjustment 24 VDC
##	See chart below for electronic control options

\*Not functional control as such

Additional Control Options	
0	No other options
2	Displacement sensor **
T	Torque Limiter Control (Used with AM, AN or L0 control options)

\*\* mandatory with "W\*\*\*", "X\*\*\*", "Y\*\*\*", "Z\*\*\*" "D" and "Y"

Port Orientation	
E	End Ports
S	Side Ports
T	Side Ports with Thru-Drive

Adjustable Displacement Stops* (For E & S Port Orientation Only)	
0	None
1	Adjustable maximum displacement stop
2	Adjustable minimum displacement stop
3	Adjustable maximum and minimum displacement stop

\*Not available with Thru-Drive

Thru-Drive Mounting Pad/Coupling	
0	No Thru-Drive
A	SAE 82-2 (A), 16 (A), 9T coupling
B	SAE 101-2 (B), 22 (B), 11T coupling
Q	SAE 101-2 (B), 25 (B-B), 13T coupling
J	SAE 101-2 (B), rotated 45 degrees, 22 (B), 15T coupling
K	SAE 101-2 (B), rotated 45 degrees, 25 (B-B), 13T coupling
C	SAE 127-4 (C), 32 (C), 14T coupling
N	SAE 127-4 (C), 38 (C-C), 17T coupling
D	SAE 152-4 (D), 44 (D), 13T coupling

Paint	
00	No Paint
PB	Black Paint

Electronic Control Options	
#	#

0	No ECU
D	Proportional displacement control
Y	Proportional pressure control

P	Electronic valve with zero displacement default
T	Electronic valve with max displacement default
S	Electronic valve with zero displacement default and hydromechanical Pmax
U	Electronic valve with max displacement default and hydromechanical Pmax
W	Electronic valve with zero displacement default (CANBUS compatible)
Y	Electronic valve with max displacement default (CANBUS compatible)
X	Electronic valve with zero displacement default and hydromechanical Pmax (CANBUS compatible)
Z	Electronic valve with max displacement default and hydromechanical Pmax (CANBUS compatible)

\*\*\* W, X, Y and Z only available with "D" and "Y"

## P2 High Pressure/High Speed Mobile Piston Pumps



The variable displacement piston pumps from Parker Hannifin, designated “P2”, are intended for mobile and industrial applications, featuring a very compact design, low noise level and low pressure ripple.

Stable and quick to respond to system demands in many different types of mobile machinery, the P2 is designed for cost effective installation within the limited space available on modern mobile machines.

### Pump Performance Data

Model Series	Displacement in <sup>3</sup> /rev (cc/rev)	Max. Outlet Pressure PSI (BAR)	Rated Drive Speed RPM	Flow GPM (LPM)	Input Horsepower HP (KW)
P2060	3.66 (60)	4600 (320)	2800	42 (159)	96 (72)
P2075	4.58 (75)	4600 (320)	2500	48 (182)	145 (108)
P2105	6.41 (105)	4600 (320)	2300	61 (231)	185 (138)
P2145	8.85 (145)	4600 (320)	2200	78 (295)	240 (179)

### Markets

### Applications

Forestry	Feller Bunchers, Knuckle Boom Loader, Skidder, Forwarder
Construction	Wheel Loader, Dozers, Off-Highway Trucks,
Mining	Drill Rigs, Loaders
Material Handling	Truck Mounted Cranes, Lift Trucks, Reachstacker
Recycling	Shredders, Balers, Compactors





# Piston Pumps (Mobile & Industrial)

## P2 High Pressure/High Speed Mobile Piston Pumps

### Performance Characteristics

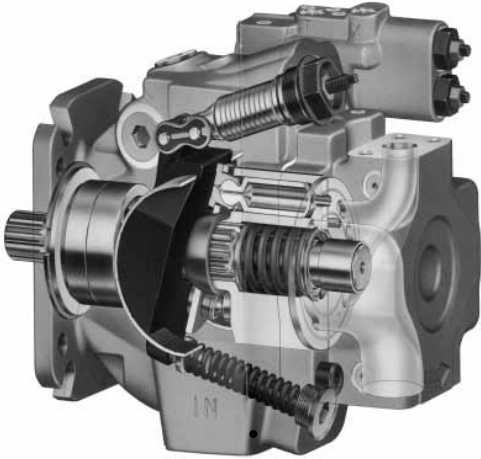

### Benefits/Features

- Compact
- Low noise level
- Sealed shaft bearing
- Service friendly
- Reliable
- Long-lasting
- Flexible
- Easy to install
- High self-priming speed

**P2 Series Input Drive Power - 2000 RPM**

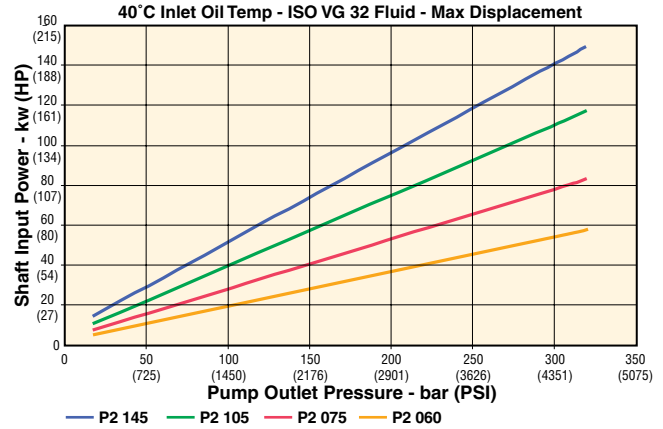

**P2 Series Pump Outlet Flow - 2000 RPM**

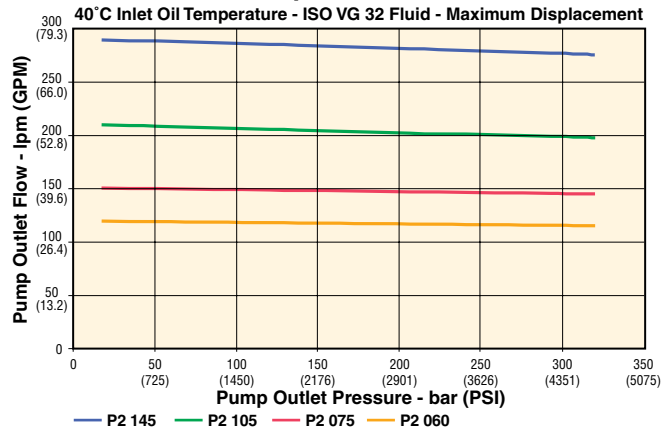

**P2 Series Overall Efficiency - 2000 RPM**

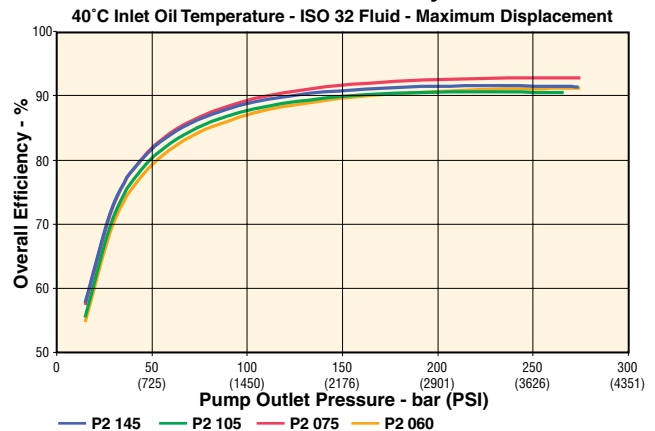

## P2 High Pressure/High Speed Piston Pumps

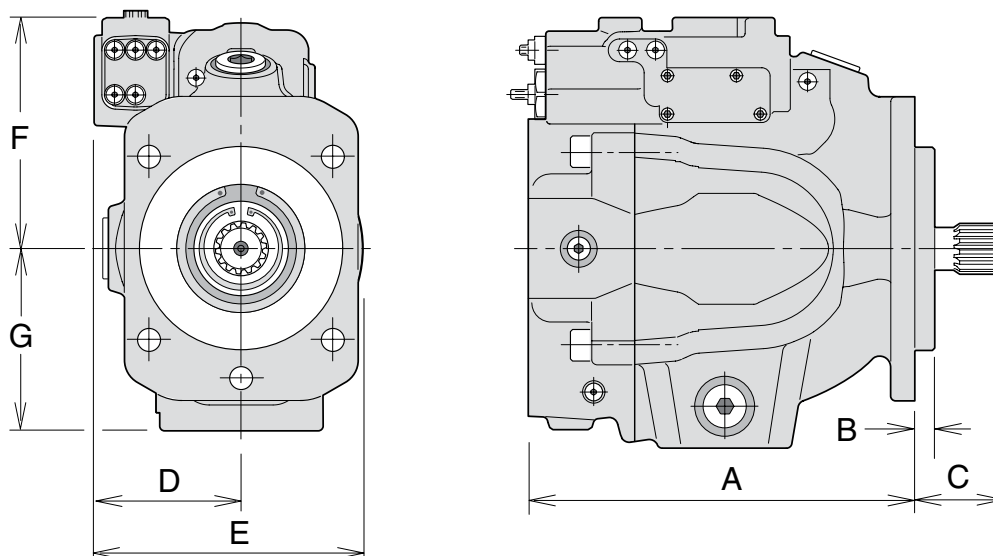

### Dimensions, inch (mm)

Series	A Max*	B Max.	C Max.	D	E Max.	F	G
P2060	11.8 (299)	0.49 (12.5)	2.19 (55.6)	3.62 (92)	6.74 (171.3)	5.55 (141)	4.49 (114)
P2075	12.9 (327.5)	0.49 (12.5)	2.44 (62.0)	4.41 (112)	7.63 (193.8)	5.71 (145)	4.84 (123)
P2105	14.1 (358)	0.49 (12.5)	2.98 (75.7)	4.41 (112)	8.35 (212.0)	6.89 (175)	—
P2145	14.7 (375)	0.50 (12.7)	2.98 (75.7)	4.65 (118)	8.86 (225.0)	7.13 (181)	6.46 (164)

\* With thru-shaft option

### Thru-Drive Kits for P2 Series (Nitrile Seals, UNC Threads, Couplings)

Thru-Drive Mounting	P2060 Kit #	P2075 Kit #	P2105 Kit #	P2145 Kit #
SAE A with 9 tooth spline	P2-060-0215-01N	P2-075-0215-01N	P2-105-0215-01N	P2-145-0215-01N
SAE B with 13 tooth spline	P2-060-0216-01N	P2-075-0216-01N	P2-105-0216-01N	P2-145-0216-01N
SAE B with 15 tooth spline	P2-060-0217-01N	P2-075-0217-01N	P2-105-0217-01N	P2-145-0217-01N
SAE C with 14 tooth spline	P2-060-0218-01N	P2-075-0218-01N	P2-105-0218-01N	P2-145-0218-01N
SAE D with 13 tooth spline	Not Available	Not Available	Not Available	P2-145-0220-01N



# Piston Pumps

## P2 Model Ordering Code

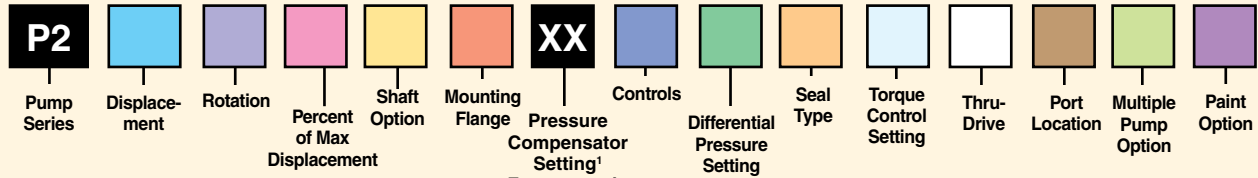

Code	Displacement in <sup>3</sup> /rev (cm <sup>3</sup> /rev)
060	3.7 (60)
075	4.6 (75)
105	6.4 (105)
145	8.8 (145)

Code	Rotation*
R	Right (CW)
L	Left (CCW)

\* Viewed from shaft end.

Code	Percent of Max. Displacement
00	100% Stroke, standard factory setting
XX	Range is 70-99 (70% to 99%)

Code	Shaft Option				
	Type	060	075	105	145
B1	SAE B Spline <sup>(1)</sup>	x			
B2	SAE BB Spline	x			
C1	SAE C Spline	x	x	x	x
C2	SAE CC Spline <sup>(2)</sup>		x	x	
C3	SAE C Spline <sup>(2)</sup>		x	x	x
C5	SAE C Key	x	x	x	x
C6	SAE CC Key <sup>(2)</sup>		x	x	x
D1	SAE D Spline			x	x
D3	SAE D Key				x

<sup>(1)</sup> 060 non thru-drive only <sup>(2)</sup> 075 thru-drive version only

Code	Mounting Flange			
	060	075	105	145
B	SAE B 2-Bolt			
C	SAE C 4-Bolt	SAE C 2/4-Bolt	SAE C 2/4-Bolt	SAE C 2-Bolt
D				SAE D 4-Bolt

Code	Controls
PA	Std. max pressure control (Pmax), 120-320 bar (1740-4600 PSI)
LA	Load sensing (2 spool)/Pmax without bleed orifice
LB	Load sensing (2 spool)/Pmax with bleed orifice
TA <sup>(3)</sup>	Torque/LS/Pmax without bleed orifice, Torque range 20-60% of max
TB <sup>(3)</sup>	Torque/LS/Pmax with bleed orifice, Torque range 20-60% of max
TC <sup>(3)</sup>	Torque/LS/Pmax without bleed orifice, Torque range 50-90% of max
TD <sup>(3)</sup>	Torque/LS/Pmax with bleed orifice, Torque range 50-90% of max

<sup>(3)</sup> See table at left for information and example.  
<sup>(4)</sup> For Remote Pressure Compensator, order the "PA" model and remove plug from "X" port.

☐ = Not Available

<sup>1</sup> For example, 32 = 320 bar setting

**XX**  
 Pressure Compensator Setting<sup>1</sup>  
 Factory set in bar times 10;  
 Range 12-32

Code	Differential Pressure Setting
20	Recommended Initial Factory Setting
00	Use with PA Control only
XX	Factory set in bar – Range 12-35

Code	Seal Type
N	Nitrile, single shaft seal
D	Nitrile, double shaft seal – "wet flange"
V	Fluorocarbon, single shaft seal
T	Fluorocarbon, double shaft seal – "wet flange"

Code	Torque Control Setting (%)
00	For Non-torque Control Pumps
XX	20-90% of Max. Rated Torque <sup>(3)</sup>

<sup>(3)</sup> See table below at left for information and example.

Code	Thru-drive
S1	No Thru-drive
T1	Thru-drive with Cover
A1	SAE A – 2-Bolt with SAE A Spline
B1	SAE B – 2-Bolt with SAE B Spline
B2	SAE B – 2-Bolt with SAE BB Spline
C2	SAE C – 2-Bolt with SAE CC Spline (145 only)
C3	SAE C – 4-Bolt with SAE C Spline
C4	SAE C – 4-Bolt with SAE CC Spline (145 only)
D3	SAE D – 4-Bolt with SAE D Spline (145 only)

### P2 Torque Control Options TA, TB, TC, TD Ordering Guide

Model	Maximum Rated Torque		TA/TB Adj. Range 20%-60% of Max Torque		TC/TD Adj. Range, 50%-90% of Max Torque	
	Nm	lb-in	Nm	lb-in	Nm	lb-in
P2060	339	3004	68-204	600-1802	170-306	1502-2703
P2075	424	3755	85-254	751-2253	212-382	1877-3379
P2105	594	5257	119-356	1051-3154	297-535	2628-4731
P2145	820	7259	164-492	1451-4355	410-738	3629-6533

The input torque limit is factory set at a percentage of the maximum rated input torque. The percentage needs to be specified in Torque Control Setting (%) box of the ordering code. For example, for a P2075-TC pump with an input torque limit setting required of 300 Nm, divide 300 into 424, which equals 71%, so 71 is specified in Torque Control Setting (%) box.

Code	Port Location
A	Side Flanges, UNC
B	Side Flanges, ISO 6149 (Metric)
G*	Rear Flanges, UNC
H*	Rear Flanges, ISO 6149 (Metric)

\* Available on P2060 only.

Code	Multiple Pump Option
1	Single Pump
2	Front Pump of Multiple Pumps
3	Middle Pump of Multiple Pumps
4	Rear Pump of Multiple Pumps

Code	Paint Option
P	Parker Black
U	No Paint

## P3 High Pressure/Super Charged Mobile Piston Pumps



P3 Piston Pumps are ideal for open circuit mobile applications with high self priming speed and operating pressure up to 4650 PSI (320 BAR). These high performance pumps are suited for mobile applications where inlet fill characteristics are not ideal; i.e. high altitudes, long inlet lines, cold weather and high pump drive speeds.

### Pump Performance Data

Model Series	Displacement in <sup>3</sup> /rev (cc/rev)	Max. Outlet Pressure PSI (BAR)	Rated Drive Speed RPM	Flow GPM (LPM)	Input Horsepower HP (KW)
P3075	4.58 (75)	4650 (320)	3000	57 (215.8)	173 (129.0)
P3105	6.41 (105)	4650 (320)	2600	67 (253.6)	210 (156.6)
P3145	8.85 (145)	4650 (320)	2500	90 (340.7)	270 (201.3)

### Markets

### Applications

Forestry	Feller Bunchers, Knuckle Boom Loader, Skidder, Forwarder
Construction	Wheel Loader, Dozers, Off-Highway Trucks,
Mining	Drill Rigs, Loaders
Material Handling	Truck Mounted Cranes, Lift Trucks, Reachstacker



# Piston Pumps (Mobile)

## P3 High Pressure/Super Charged Mobile Piston Pumps

### Performance Characteristics

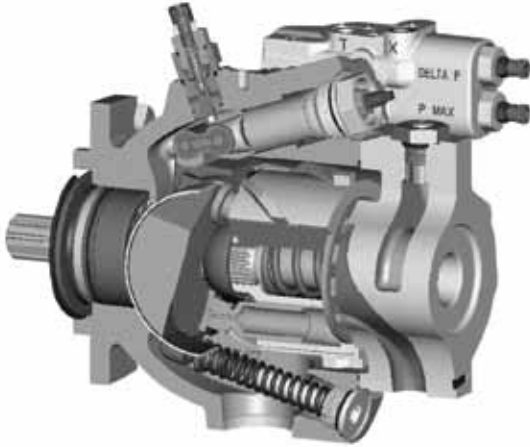

### Benefits/Features

- Compact
- Low noise level
- Sealed shaft bearing
- Service friendly
- Reliable
- Long-lasting
- Flexible
- Easy to install
- High self-priming speed

**P3 Series Input Drive Power - 2000 RPM**

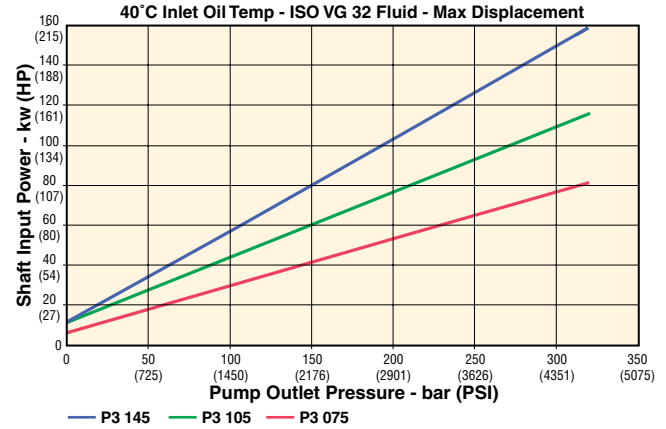

**P3 Series Pump Outlet Flow - 2000 RPM**

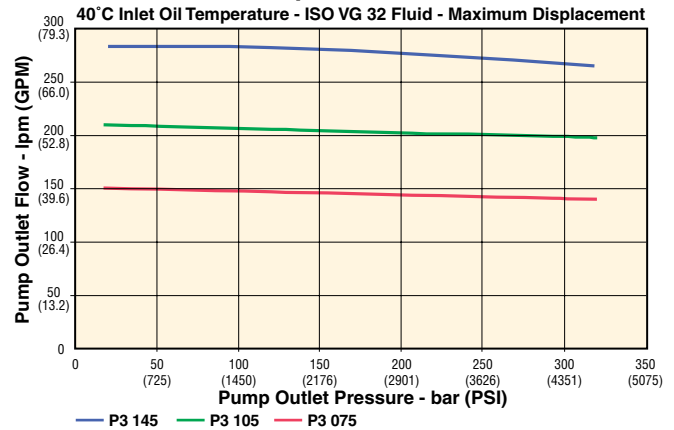

**P3 Series Overall Efficiency - 2000 RPM**

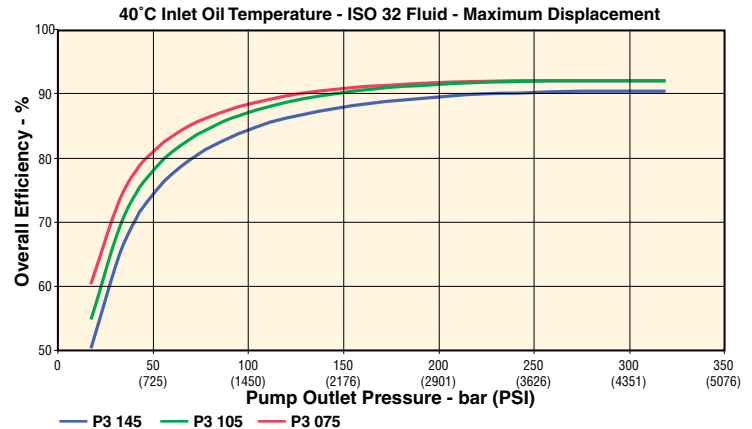

## P3 High Pressure/Super Charged Mobile Piston Pumps

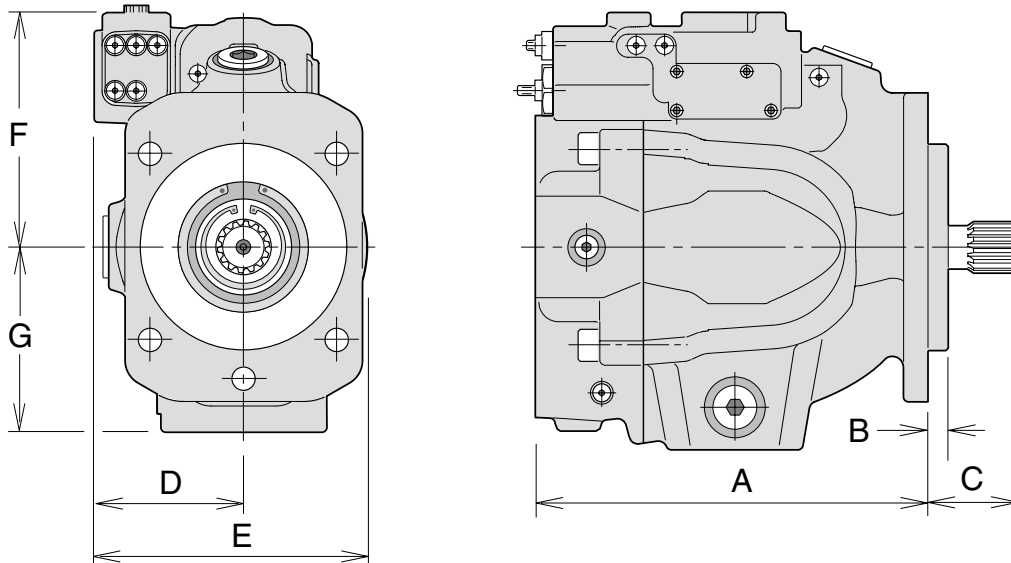

### Dimensions, inch (mm)

Series	A Max*	B Max.	C Max.	D	E Max.	F	G
P3075	12.89 (327.5)	14.76 (12.5)	2.44 (62)	4.41 (112)	6.86 (176)	5.71 (145)	4.72 (120)
P3105	12.89 (327.5)	0.49 (12.5)	2.98 (75.6)	4.41 (112)	8.26 (210)	7.17 (182)	5.87 (150)
P3145	14.76 (375.0)	0.50 (12.7)	2.98 (75.6)	4.49 (114)	8.98 (228)	7.13 (181)	6.34 (161)

\* With thru-shaft option

### Thru-drive Kits for P2 Series (Nitrile Seals, UNC Threads, Couplings)

Thru-drive Mounting	P3075 Kit #	P3105 Kit #	P3145 Kit #
SAE A with 9 tooth spline	P2-075-0215-01N	P2-105-0215-01N	P2-145-0215-01N
SAE B with 13 tooth spline	P2-075-0216-03N	P2-105-0216-03N	P2-145-0216-03N
SAE B with 15 tooth spline	P2-075-0217-03N	P2-105-0217-03N	P2-145-0217-03N
SAE C with 14 tooth spline	P2-075-0218-03N	P2-105-0218-03N	P2-145-0218-03N
SAE D with 13 tooth spline	Not Available	Not Available	P2-145-0220-03N





# Piston Pumps

## P3 Model Ordering Code

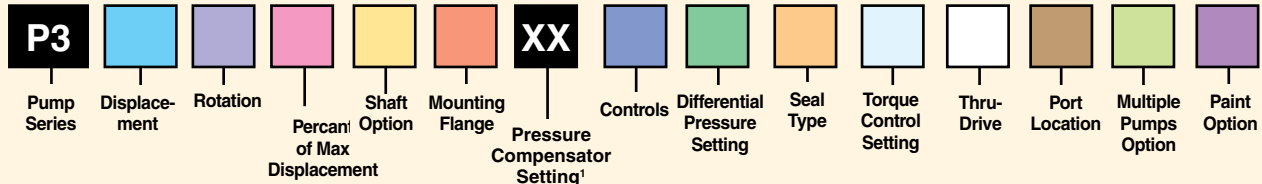

Code	Displacement in <sup>3</sup> /rev (cm <sup>3</sup> /rev)
075	4.6 (75)
105	6.4 (105)
145	8.8 (145)

Code	Rotation*
R	Right (CW)
L	Left (CCW)

\* Viewed from shaft end.

Code	Percent of Max. Displacement
00	100% Stroke, standard factory setting
XX	Range is 70-99 (70% to 99%)

Code	Shaft Option			
	Type	075	105	145
C1	SAE C Spline	x	x	x
C2	SAE CC Spline <sup>(2)</sup>	x	x	
C3	SAE C Spline <sup>(2)</sup>	x	x	x
C5	SAE C Key	x	x	x
C6	SAE CC Key <sup>(2)</sup>	x	x	x
D1	SAE D Spline		x	x
D3	SAE D Key			x

<sup>(2)</sup> 075 thru-drive version only

Code	Mounting Flange		
	075	105	145
C	SAE C 2/4-Bolt	SAE C 2/4-Bolt	SAE C 2-Bolt
D			SAE D 4-Bolt

Code	Controls
PA <sup>(4)</sup>	Std. max pressure control (Pmax), 100-320 bar (1450-4600 PSI)
LA	Load sensing (2 spool)/Pmax without bleed orifice
LB	Load sensing (2 spool)/Pmax with bleed orifice
TA <sup>(3)</sup>	Torque/LS/Pmax without bleed orifice, Torque range 20-60% of max
TB <sup>(3)</sup>	Torque/LS/Pmax with bleed orifice, Torque range 20-60% of max
TC <sup>(3)</sup>	Torque/LS/Pmax without bleed orifice, Torque range 50-90% of max
TD <sup>(3)</sup>	Torque/LS/Pmax with bleed orifice, Torque range 50-90% of max

<sup>(3)</sup> See table at left for information and example.

<sup>(4)</sup> For Remote Pressure Compensator, order the "PA" model and remove plug from "X" port.

■ = Not Available

<sup>1</sup> For example, 32 = 320 bar setting

**XX**  
Pressure Compensator Setting!  
Factory set in bar times 10;  
Range 100-320

Code	Differential Pressure Setting
20	Recommended Initial Factory Setting
00	Use with PA Control only
XX	Factory set in bar – Range 10-35

Code	Seal Type
N	Nitrile, single shaft seal
D	Nitrile, double shaft seal – "wet flange"
V	Fluorocarbon, single shaft seal
T	Fluorocarbon, double shaft seal – "wet flange"

Code	Torque Control Setting (%)
00	For Non-torque Control Pumps
XX	20-90% of Max. Rated Torque <sup>(3)</sup>

<sup>(3)</sup> See table at bottom left for information and example.

Code	Thru-drive
S1	No Thru-drive
T1	Thru-drive with Cover
A1	SAE A – 2-Bolt with SAE A Spline
B1	SAE B – 2-Bolt with SAE B Spline
B2	SAE B – 2-Bolt with SAE BB Spline
C2	SAE C – 2-Bolt with SAE CC Spline (145 only)
C3	SAE C – 4-Bolt with SAE C Spline
C4	SAE C – 4-Bolt with SAE CC Spline (145 only)
D3	SAE D – 4-Bolt with SAE D Spline (145 only)

### P3 Torque Control Options TA, TB, TC, TD Ordering Guide

Model	Maximum Rated Torque		TA/TB Adj. Range 20%-60% of Max Torque		TC/TD Adj. Range, 50%-90% of Max Torque	
	Nm	lb-in	Nm	lb-in	Nm	lb-in
P3075	424	3755	85-254	751-2253	212-382	1877-3379
P3105	594	5257	119-356	1051-3154	297-535	2628-4731
P3145	820	7259	164-492	1451-4355	410-738	3629-6533

The input torque limit is factory set at a percentage of the maximum rated input torque. The percentage needs to be specified in Torque Control Setting (%) box of the ordering code. For example, for a P3075-TC pump with an input torque limit setting required of 300 Nm, divide 300 into 424, which equals 71%, so 71 is specified in Torque Control Setting (%) box.

Code	Port Location
A	Side Flanges, UNC
B	Side Flanges, ISO 6149 (Metric)

Code	Multiple Pump Option
1	Single Pump
2	Front Pump of Multiple Pumps
3	Middle Pump of Multiple Pumps
4	Rear Pump of Multiple Pumps

Code	Paint Option
P	Parker Black
U	No Paint

## PVplus High Pressure Industrial Piston Pumps



PVplus piston pumps are ideal for heavy duty industrial applications with operating pressure up to 5000 PSI (350 BAR). These pumps respond quickly to system demands and, with the use of “ripple chamber” technology, are some of the quietest piston pumps available.

- High strength cast-iron housing
- Modular controls
- Large control piston for fast response
- Thru-shaft option with 100% thru torque capability
- Multiple pressure control
- Pre-Compression chamber

### Pump Performance Data

Model Series	Displacement in <sup>3</sup> /rev (cc/rev)	Max. Outlet Pressure PSI (BAR)	Max Rated Drive Speed RPM	Pump Flow 1800 RPM & 100 PSI GPM (LPM)	Input Horsepower 1800 RPM & 5000 PSI HP (KW)
PV016	0.98 (16)	5000 (350)	3000 RPM	8 (30.3)	25 (18.6)
PV020	1.22 (20)	5000 (350)	3000 RPM	9.5 (36.0)	31 (23.1)
PV023	1.40 (23)	5000 (350)	3000 RPM	11 (41.6)	34 (25.4)
PV028	1.71 (28)	5000 (350)	3000 RPM	13 (49.2)	40 (29.8)
PV032	1.95 (32)	5000 (350)	2800 RPM	15 (56.8)	47 (35.0)
PV040	2.44 (40)	5000 (350)	2800 RPM	19 (71.9)	62 (46.2)
PV046	2.81 (46)	5000 (350)	2800 RPM	22 (83.3)	67 (50.0)
PV063	3.84 (63)	5000 (350)	2800 RPM	30 (113.6)	94 (70.1)
PV080	4.88 (80)	5000 (350)	2500 RPM	38 (143.9)	120 (89.5)
PV092	5.61 (92)	5000 (350)	2300 RPM	44 (166.6)	184 (137.2)
PV140	8.54 (140)	5000 (350)	2400 RPM	67 (253.6)	200 (149.1)
PV180	10.98 (180)	5000 (350)	2200 RPM	86 (235.5)	282 (210.3)
PV270	16.48 (270)	5000 (350)	1800 RPM	128 (484.5)	400 (298.3)
PV360	21.97 (360)	5000 (350)	1750 RPM	160 (605.7)	500 (372.8)

### Markets

Markets	Applications
Industrial	Presses, Shears, Injection Molding, Aircraft Test Stands, Test Equipment, Simulators
Oil & Gas	Nitrogen Pumpers, Cementers, Coil Tubing, Oil Lift Pumps
Construction	Wheel Loader
Mining	Drill Rigs, Tunneling Equipment
Material Handling	Conveyor Drives, Apron Feeders, Rail Car Tippers, Mixers
Recycling	Shredders, Balers, Compactors

## PVplus High Pressure Industrial Piston Pumps

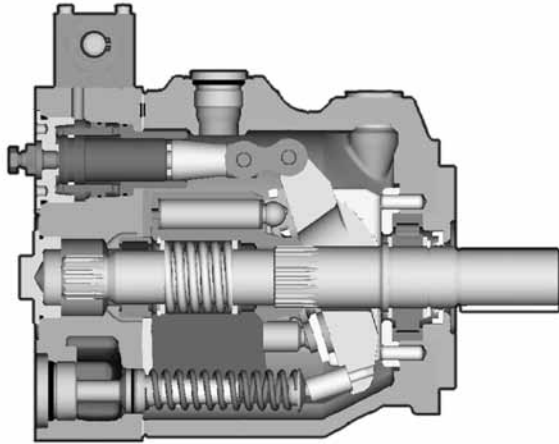

### Benefits/Features

- High strength cast-iron housing for high reliability and quiet operation
- Modular controls for field convertibility
- Large control piston for fast response
- Thru-shaft option with 100% thru torque capability
- Multiple pressure control with valves mounted directly on pump
- Pre-compression chamber to minimize over-all system noise
- High self-priming speed and cold start capability

## PVplus High Pressure Industrial Piston Pumps

### Performance Characteristics

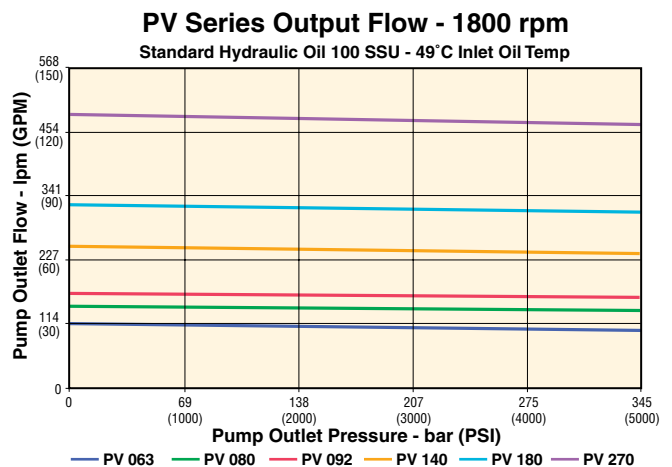
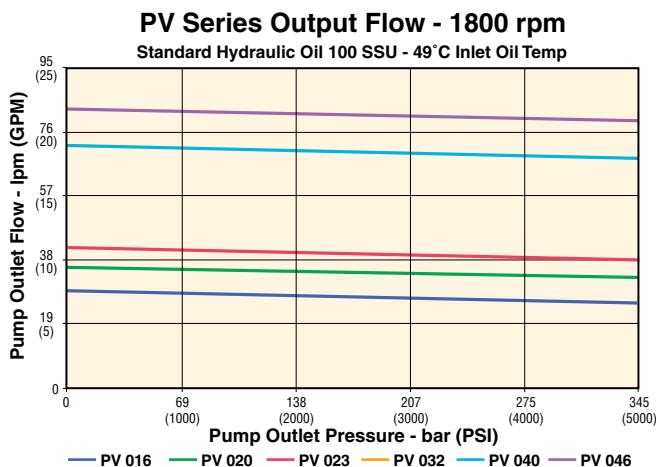
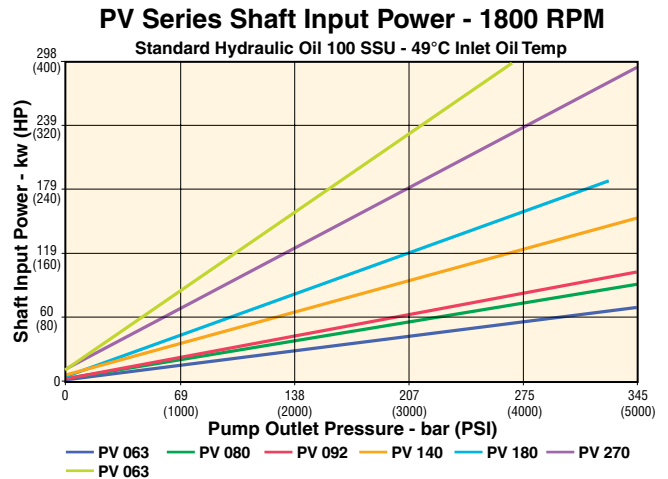
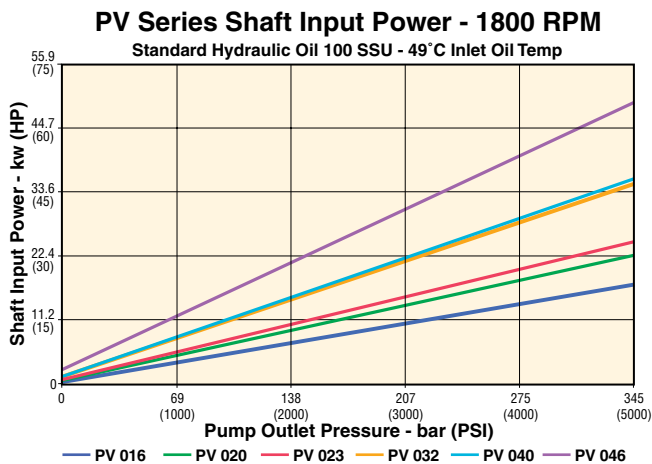
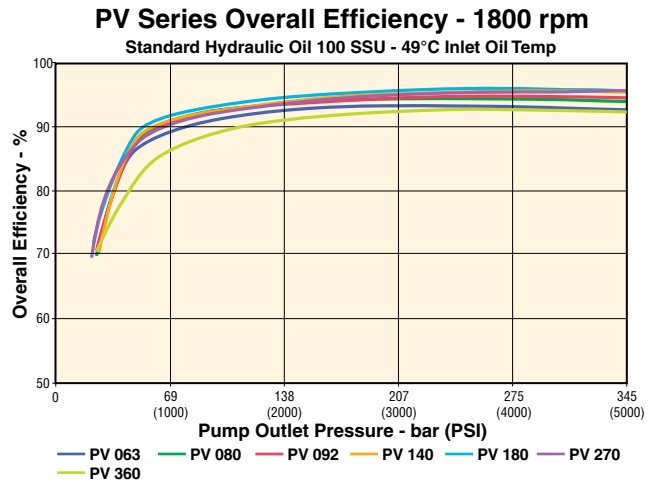
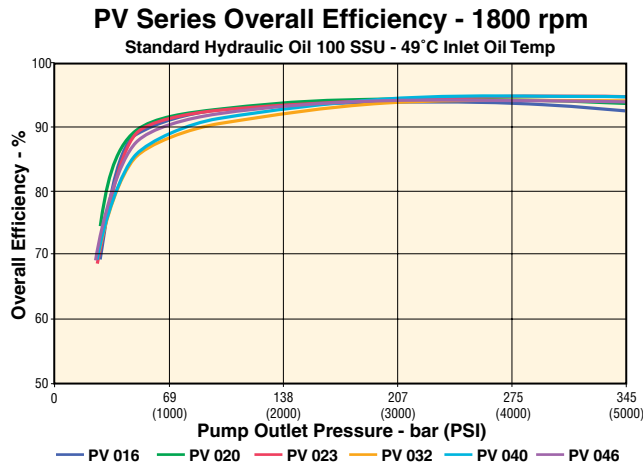

For 360 Consult Factory

## PVplus High Pressure Industrial Piston Pumps

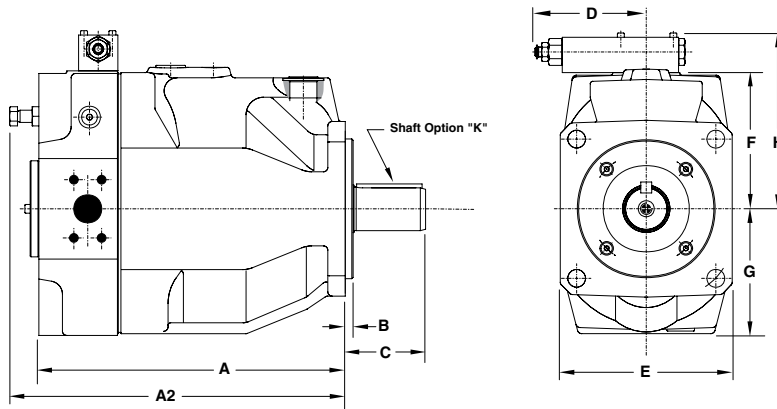

### Dimensions, inch (mm)

Model	A	A2 Max.	B	C	D Max.	E	F	G	H
PV016/020/023	77.8 (195)	83.5 (212)	0.37 (9)	2.0 (52)	0.49 (12.44)	5.2 (132)	3.7 (94)	3.1 (80)	5.5 (140)
PV032/040/046	89 (227)	96 (245)	0.50 (9)	2.7 (68)	2.19 (55.62)	6.1 (156)	4.2 (107)	3.6 (92)	6.0 (153)
PV063/080/092	112.9 (287)	120.5 (306)	0.50 (9)	3.6 (92)	4.25 (107.95)	8.0 (204)	5.3 (135)	4.6 (118)	7.1 (181)
PV140/180	138 (350)	152 (385)	0.50 (9)	3.6 (92)	4.25 (107.95)	7.8 (200)	6.2 (158)	5.7 (145)	8.0 (204)
PV270	186 (472.5)	201 (510)	0.50 (9)	4.5 (115)	—	10.4 (265)	7.2 (184)	6.9 (176)	9.1 (230)
PV360	187.7 (477)	201 (510)	0.50 (9)	4.5 (115)	—	98.4 (250)	7.2 (184)	6.9 (176)	9.1 (230)

### Filtration and auxiliary function pump suggestions



#### Pump

Model Code	Flow @1800 RPM GPM (LPM)	Pressure PSI (BAR)
T67B-B02-3R00-A100	3 (11.4)	4000 (275.8)
T67B-B04-3R00-A100	6 (22.7)	4000 (275.8)
T67B-B07-3R00-A100	10 (37.9)	4000 (275.8)

#### Thru-Drive Kits

Pump Series	Kit #	Mount
PV016/020/023	MK-PVBG1BSN45 plus MK-PVBG1K1342	SAE B
PV032/040/046	MK-PVBG2BSN40 plus MK-PVBG2K1340	SAE B
PV063/080/092	MK-PVBG3BSN41 plus MK-PVBG3K1341	SAE B
PV140/180	MK-PVBG4BSN40 plus MK-PVBG4K1340	SAE B
PV270	MK-PVBG5BSN40 plus MK-PVBG5K1340	SAE B
PV270	MK-PVBG5BSN40 plus MK-PVBG5K1340	SAE B

\* Verify correct design series

# Piston Pumps

## PVplus 016-046cc Model Ordering Code

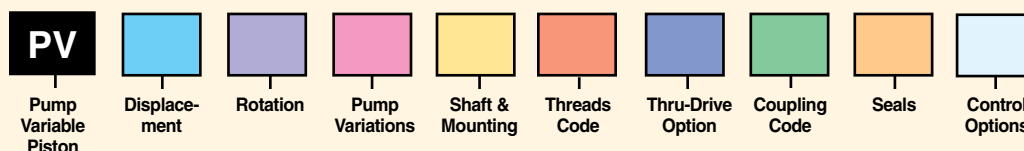

Code	Displacement in <sup>3</sup> /rev (cc/rev)
016	.98 (16)
020	1.2 (20)
023	1.4 (23)
028	1.7 (28)
032	1.9 (32)
040	2.4 (40)
046	2.8 (46)

Code	Rotation*
R	CW
L	CCW

\*As viewed from shaft end.

Code	Pump Variations
1	Standard
9*	Customized Displacement and/or Pressure Setting

\*Specify in cc/rev and/or bar.

Code	Shaft & Mounting			
	PV016/020/023		PV032/040/046	
	Shaft	Pilot	Shaft	Pilot
D	1" Keyed (SAE BB)	4 Bolt SAE B	1 1/4" Keyed (SAE C)	4 Bolt SAE C
E	15T Spline (SAE BB)	4 Bolt SAE B	14T Spline (SAE C)	4 Bolt SAE C
K	25mm Keyed	4 Bolt 100mm	32mm Keyed	4 Bolt 125mm
L	W25 x 1.5 x 15 x 8f Spline DIN 5480	4-Bolt 100mm	W32 x 1.5 x 20 x 8f Spline DIN 5480	4 Bolt 125mm

Code	Threads Code	
	Port*	Threads**
1	BSPP	Metric
3	UNF	UNC
7	ISO 6149	UNC
8	ISO 6149	Metric

\*Drain, gage, and flushing ports.  
\*\* Mounting and connecting threads

Code	Thru-Drive Option (1st Digit)	Code	Second Pump (2nd Digit)
T	Single Pump Prepared for Thru-Drive	1	Single Pump, No Coupling
	<b>With Adapter for Second Pump</b>	H	w/Coupling, 25 x 1.5 x 15, DIN 5480
Y <sup>1</sup>	SAE AA, Ø2.00in (Ø50.8mm)	J	w/Coupling, 32 x 1.5 x 20, DIN 5480
A	SAE A, Ø3.25in (Ø82.55mm)	Y	w/SAE Coupling, 9T-16/32 DP
B	SAE B, Ø4.00in (Ø101.6mm)	A	w/SAE Coupling, 11T-16/32 DP
C <sup>2</sup>	SAE C, Ø5.00in (Ø127mm)	B	w/SAE Coupling, 13T-16/32 DP
G	Metric, Ø2.48in (Ø63mm)	C*	w/SAE Coupling, 15T-16/32 DP
H	Metric, Ø3.15in (Ø80mm)	D	w/SAE Coupling, 14T-12/24 DP
J	Metric, Ø3.94in (Ø100mm)	E	w/SAE Coupling, 17T-12/24 DP
K <sup>2</sup>	Metric, Ø4.92in (Ø125mm)		

<sup>1</sup> Only for PV016 thru PV023  
<sup>2</sup> Only for PV032 and larger  
\* Only for PV032 and larger

Code	Coupling Code
1	Single pump, no coupling
H	with coupling 25 x 1.5 x 15, DIN 5480
J	with coupling 32 x 1.5 x 20, DIN 5480
Y	with coupling SAE A 9T-16/32 DP
A	with coupling SAE - 11T-16/32 DP
B	with coupling SAE B 13T-16/32 DP
C	with coupling SAE B-B 15T-16/32 DP
D	with coupling SAE C 14T-12/24 DP

Code	Seals
N	Nitrile
V	Fluorocarbon
W	Nitrile w/PTFE Shaft Seal
P	FPM w/PTFE Shaft Seal

Code	Control Options
<b>Standard Pressure Compensator</b>	
0 0 1	No Compensator
1 0 0	With Cover Plate, No Control Function
M M	Standard pressure control, integrated pilot valve
M R	Remote pressure control, integrated pilot valve
M F	Load Sensing (flow) control, integrated pilot valve
M T	Two spool LS control
<b>Remote/Load Sense Compensator</b>	
C	Standard version <sup>1</sup>
1	NG6 interface top side for pilot valves
W	With unloading function, 24VDC solenoid <sup>1</sup>
K	Prop.-pilot valve type PVACRE..35 mounted
Z	Without integrated pilot valve, NG6 interface, for mounting of accessory code PVAC
P	MT1 with mounted pilot valve PVAC1P <sup>2</sup>
<b>Horsepower Compensator Control</b>	
<b>Nominal Horsepower at 1500 RPM</b>	
B	3 HP (19.5 Nm Torque)
C	4 HP (26 Nm Torque)
D	5.5 HP (36 Nm Torque)
E	7.5 HP (49 Nm Torque)
G	11 HP (71 Nm Torque)
H	15 HP (97 Nm Torque)
K	18.5 HP (120 Nm Torque)
M	22 HP (142 Nm Torque)
S	30 HP (195 Nm Torque)
<b>Function</b>	
L	Horsepower Compensator
C	Horsepower Compensator & Load Sensing
<b>Variation</b>	
A	NG6 Interface Top Side
B	No Pressure Compensation
C	Adjustable Pressure Compensation
D	Proportion Pilot Valve PVACPP* Mounted
Z	Accessories Mounted
<b>Electro Hydraulic Control Options</b>	
F P V	Proportional displacement control, no pressure compensation
U P	Proportional displacement control, with pressure compensation

1 Not for MT  
2 Only for MT

**NOTES:**  
Compensator differential  $\Delta p$  is to be adjusted:  
Remote pressure comp., horsepower comp. 15 ± 1 bar  
Load-sensing comp. (not horsepower comp.) 10 ± 1 bar  
(Codes MF\* and LS part of MT\*)  
**Consult catalog on CD for electrohydraulic control options.**





# Piston Pumps

## PVplus 063-360cc Model Ordering Code

<b>PV</b>									
Pump Variable Piston	Displace- ment	Rotation	Variations	Shaft & Mounting	Threads Code	Thru-Drive Option	Coupling Code	Seals	Control Options

Code	Displacement in <sup>3</sup> /rev (cc/rev)
063	3.8 (63)
080	4.8 (80)
092	5.6 (92)
140	8.5 (140)
180	10.9 (180)
270	16.5 (270)
360	22.0 (360)

Code	Rotation*
R	CW
L	CCW

\*As viewed from shaft end.

Code	Pump Variations
1	Standard
g*	Customized Displacement and/or Pressure Setting

\*Specify in cc/rev and/or bar.

Code	Shaft & Mounting					
	PV063/ 080/092		PV140/ 180		PV270	
	Shaft	Pilot	Shaft	Pilot	Shaft	Pilot
D	1 3/4" Keyed (SAE D)	4 Bolt SAE D	2" Keyed SAE F	4 Bolt SAE D	2" SAE Keyed	4 Bolt SAE E
E	13T Spline (SAE D)	4 Bolt SAE D	15T Spline SAE F	4 Bolt SAE D	15T Spline SAE F	4 Bolt SAE E
F			1 3/4" Keyed SAE D	4 Bolt SAE D		
G			13T Spline SAE D	4 Bolt SAE D		
K	40mm Keyed	4 Bolt 160 mm	50mm Keyed	4 Bolt 160 mm	65mm Keyed	4 Bolt 200 mm
L	W40 x 1.5 x 25 x8f Spline DIN 5480	4 Bolt 160 mm	W50 x 2 x 24 x 9g Spline DIN 5480	4 Bolt 160 mm	W60 x 2 x 28 x 9g Spline DIN 5480	4 Bolt 200 mm

Code	Threads Code	
	Port*	Threads**
1	BSPP	Metric
3	UNF	UNC
4***	BSPP-M14	Metric
7	ISO 6149	UNC
8	ISO 6149	Metric

\* Drain, gage, and flushing ports.

\*\* Mounting and connecting threads

\*\*\* Only for PV063-PV180; pressure port 1 1/4" with 4xM14 instead of 4xM12

Code	Thru-Drive Option (1st Digit)
T	Single Pump Prepared for Thru-Drive
<b>With Adapter for Second Pump</b>	
A	SAE A, Ø3.25in (Ø82.55mm)
B	SAE B, Ø4.00in (Ø101.6mm)
C	SAE C, Ø5.00in (Ø127mm)
D <sup>1</sup>	SAE D, Ø6.00in (Ø152.4) mm
E <sup>2</sup>	SAE E, Ø6.50in (Ø165.1mm)
G <sup>3</sup>	Metric, Ø2.48in (Ø63mm)
H	Metric, Ø3.15in (Ø80mm)
J	Metric, Ø3.94in (Ø100mm)
K	Metric, Ø4.92in (Ø125mm)
L <sup>1</sup>	Metric, Ø6.30in (Ø160mm)
M <sup>2</sup>	Metric, Ø7.87in (Ø200mm)

1 Only for PV063 and larger

2 Only for PV270

3 Only up to PV092

Code	Coupling Code
1	Single pump, no coupling
H	with coupling 25 x 1.5 x 15, DIN 5480
J	with coupling 32 x 1.5 x 20, DIN 5480
K	with coupling 40 x 1.5 x 25, DIN 5480
L	with coupling 50 x 2 x 24, DIN 5480
Y	with coupling SAE A 9T-16/32 DP
A	with coupling SAE - 11T-16/32 DP
B	with coupling SAE B 13T-16/32 DP
C	with coupling SAE B-B 15T-16/32 DP
D	with coupling SAE C 14T-12/24 DP
E	with coupling SAE C - C
F	with coupling SAE D, E
G	with coupling SAE F

Code	Seals
N	Nitrile
V	Fluorocarbon
W	Nitrile w/PTFE Shaft Seal
P	FPM w/PTFE Shaft Seal

Code	Second Pump* (2nd Digit)
1	No Second Pump and Coupling
2	PV140 or PV180 Mounted
3	PV Pump Mounted
4	Gear Pump Series PGP Mounted

\* Specify 2nd pump with full model code.

### COMPENSATOR NOTES:

Compensator differential Δp is to be adjusted:

Remote pressure comp., power comp. 15 ± 1 bar.

(Codes FR\*, FT\*, \*L\*, \*C\*, FPR, FPZ, FPG)

Load-sensing comp. (not power comp.) 10 ± 1 bar (Codes FF\*)

Consult catalog on CD for electrohydraulic control options.

Code	Control Options
<b>Standard Pressure Compensator</b>	
0 0 1	No Compensator
1 0 0	With Coverplate, No Control Function
M M	Standard pressure control, integrated pilot valve
M R	Remote pressure control, integrated pilot valve
M F	Load Sensing (flow) control, integrated pilot valve
M T	Two spool LS control
<b>Remote/Load Sense Compensator</b>	
C	Standard version <sup>1</sup>
1	NG6 interface top side for pilot valves
W	With unloading function, 24VDC solenoid <sup>1</sup>
K	Prop.-pilot valve type PVACRE..35 mounted
Z	Without integrated pilot valve, NG6 interface, for mounting of accessory code PVAC
P	MT1 with mounted pilot valve PVAC1P <sup>2</sup>
<b>Horsepower Compensator Control</b>	
<b>Input Horsepower at 1500 RPM</b>	
G	11 HP (71 Nm Torque)
H	15 HP (97 Nm Torque)
K	18.5 HP (120 Nm Torque)
M	22 HP (142 Nm Torque)
S	30 HP (195 Nm Torque)
T	37 HP (240 Nm Torque)
U	45 HP (290 Nm Torque)
W	55 HP (355 Nm Torque)
Y	75 HP (485 Nm Torque)
Z	90 HP (585 Nm Torque)
2	110 HP (715 Nm Torque)
3	132 HP (850 Nm Torque)
4	160 HP (850 Nm Torque)
5	180 HP (850 Nm Torque)
6	200 HP (850 Nm Torque)
<b>Function</b>	
L	Horsepower Compensator
C	Horsepower Compensator & Load Sensing
<b>Variation</b>	
A	NG6 Interface Top Side
B	No Pressure Compensation
C	Adjustable Pressure Compensation
D	Proportional Pilot Valve PVACPP* Mounted
Z	Accessories Mounted <sup>3</sup>
<b>Electro Hydraulic Control Options</b>	
F P V	Proportional displacement control, no pressure compensation
U P	Proportional displacement control, with pressurecompensation

1 Not for MT

2 Only for MT

3 Accessories not included. Please specify on order with full model code.

## Premier Series High Pressure/Performance Piston Pumps



The open circuit Premier Series pumps are variable displacement piston pumps with emphasis on superior design with few maintenance requirements. Superior inlet characteristics allow the pumps to run faster than competitive models without the added expense of boosting the inlet. Modified pistons that reduce the amount of trapped fluid volume result in improved efficiency.

The Premier Series pumps have been designed to operate on a variety of fluid types and in a wide range of industries where variable flow, high pressure and/or high speeds are required; such as: presses, construction machinery, injection molding, wood, aircraft, drilling, mining, steel and cranes.

### Pump Performance Data

Model Series	Displacement in <sup>3</sup> /rev (cc/rev)	Max. Continuous Pressure PSI (BAR)	Max. Intermittent Pressure PSI (BAR)	Max Rated Drive Speed RPM	Pump Flow 1800 RPM & 100 PSI GPM (LPM)	Input Horsepower 1800 RPM & 5000 PSI HP (KW)
P05/P080	4.90 (80.3)	6000 (420)	7250 (500)	2550	38 (143.8)	113 (84.3)
P07/P110	6.70 (109.8)	6000 (420)	7250 (500)	2450	52 (196.8)	171 (127.5)
P09/P140	8.60 (140.9)	6000 (420)	7250 (500)	2300	66.5 (251.7)	217 (161.8)
P12/P200	12.20 (200.0)	6000 (420)	7250 (500)	2100	95 (359.6)	308 (229.7)
P16/P260	16.00 (262.2)	6000 (420)	7250 (500)	1850	124 (469.4)	404 (301.3)

### Markets

### Applications

Industrial	Presses, Shears, Aircraft Test Stands, Test Equipment, Simulators
Oil & Gas	Cementer & Pumper Centrifugal Drives
Mining	Tram, Steering, Conveyors

## Premier Series High Pressure/Performance Piston Pumps

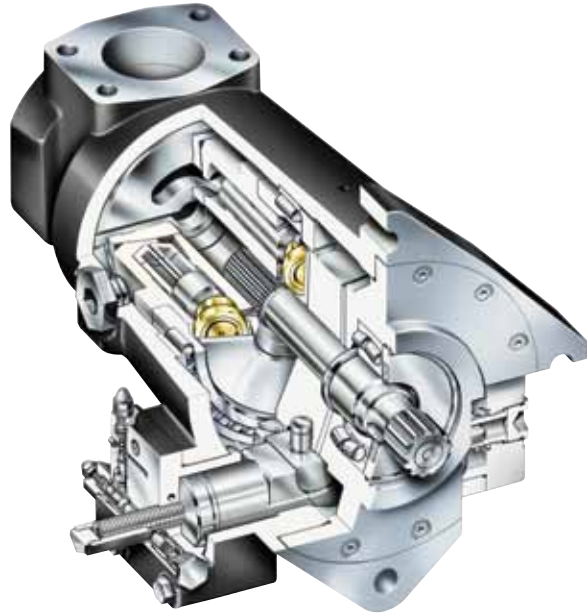

### Benefits/Features

- Highest rated pressure of any comparable pump available in the market place today.
- Full power thru-drive capability allows two (2) pumps of the same displacement to be run in tandem at full rated pressure and flow, simultaneously.
- Fast, compensator response minimizes pressure overshoot.
- Two stage, pilot operated compensator provides sharp pressure cutoff at compensator setting, typically regulating pressure within 50 PSI (3.5 BAR). Compensator may easily be remotely controlled or used in load-sensing circuits.
- Precision barrel bearing absorbs radial forces, allowing longer operation at higher pressure and higher speeds.
- Piston design minimizes trapped oil volume to maximize efficiency.
- Angled barrel ports reduce the piston circle diameter, which allows oil to enter at reduced velocity. This allows the pump to run faster, with atmospheric inlet pressure.
- Spherical port plate and barrel face provides support to barrel to offset forces from angled ports.
- Large suction port reduces inlet flow velocity to allow the pumps to run at higher speeds with atmospheric inlet.
- Standard SAE split flange with inch or metric bolts, depending on pump version (SAE or metric)
- Conforms to SAE or ISO mounting standards.
- Damped low inertia rocker cam allows very quick compensation, resulting in more stable and quieter pump.
- Heavy duty shaft bearing to absorb side and thrust loads.
- High pressure shaft seal allows higher case pressure without external leakage. Note: it is always advisable to maintain the lowest possible case pressure.
- Drive shaft options include keyed or splined in SAE, ISO and DIN.
- A wide variety of optional controls are available and are designed with simplicity and a maximum of common elements.



## Premier Series High Pressure/Performance Piston Pumps

### Performance Characteristics

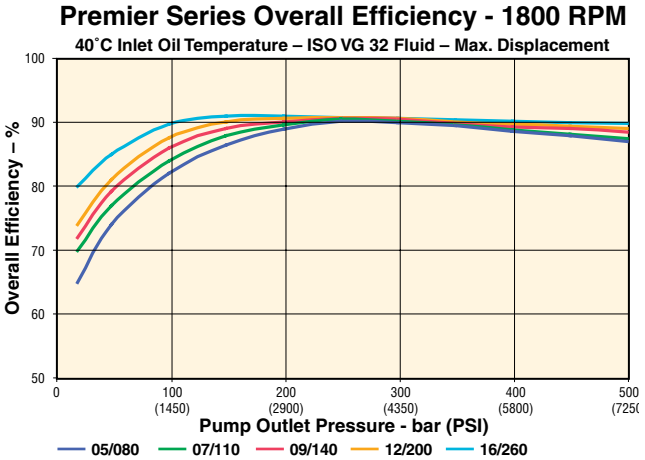
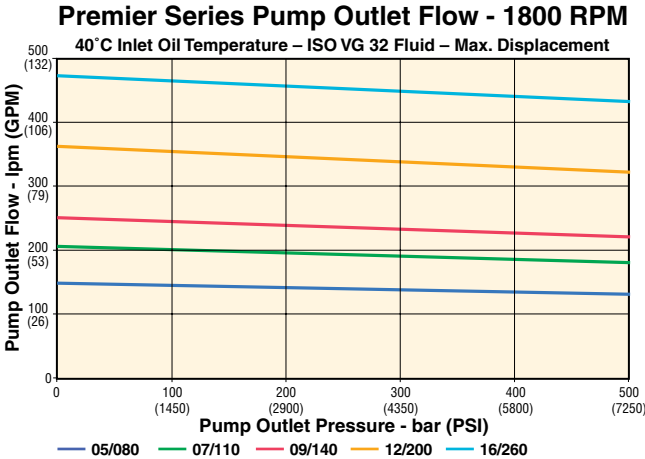
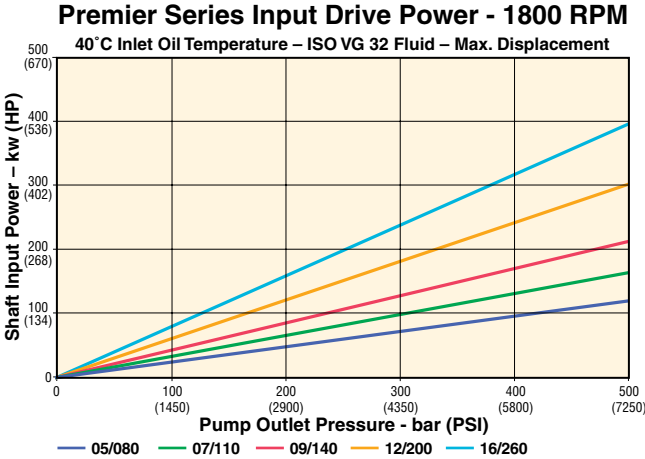

## Premier Series High Pressure/Performance Piston Pumps

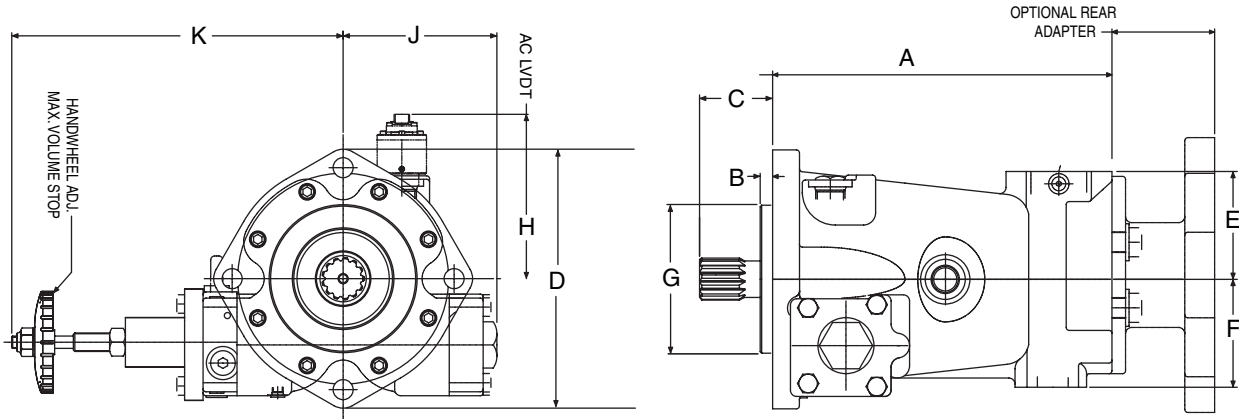

### Dimensions, inch (mm)

Series	A1*	A2*	B	C max	D	E	F	G	H	J	K
P05	13.76 (225.5)	13.4 (218.6)	0.49 (8.0)	—	10.5 (172.1)	4.37 (71.6)	4.37 (71.6)	6.000-5.998 (98.32-98.29)	7.61 (124.7)	6.23 (102.1)	13.44 (220.2)
P080	21.33 (349.5)	20.77 (340.4)	0.61 (10.0)	5.61 (92)	16.28 (266.7)	6.78 (111.1)	6.78 (111.1)	10.984-10.980 (180.00-179.93)	11.80 (193.4)	9.65 (158.2)	20.83 (341.3)
P07	14.89 (224.0)	14.71 (241.1)	0.49 (8.0)	—	10.5 (172.1)	4.37 (71.6)	4.52 (74.1)	6.000-4.998 (98.32-81.90)	7.77 (127.3)	6.26 (102.6)	13.47 (220.7)
P110	23.08 (378.2)	22.80 (373.6)	0.61 (10.0)	5.61 (92)	16.28 (266.7)	6.78 (111.1)	7.01 (114.9)	10.984-10.980 (180.00-179.93)	12.05 (197.5)	9.71 (159.2)	23.94 (392.3)
P09	16.09 (267.7)	15.91 (260.7)	0.49 (8.0)	—	11.9 (31.1)	4.5 (73.7)	4.83 (79.1)	6.000-5.998 (98.32-98.29)	8.43 (138.1)	6.79 (111.3)	14.19 (232.5)
P140	24.94 (408.7)	24.66 (404.1)	0.64 (10.5)	5.61 (92)	18.44 (302.2)	6.98 (114.3)	7.49 (122.7)	10.984-10.980 (180.00-179.93)	13.07 (214.2)	10.51 (172.3)	22.00 (360.5)
P12	17.26 (282.8)	17.15 (281.0)	0.63 (10.3)	—	14.8 (242.5)	4.5 (73.7)	5.37 (88.0)	6.500-6.498 (106.52-106.48)	8.26 (135.4)	6.92 (113.4)	14.31 (234.5)
P200	26.75 (438.4)	26.58 (435.6)	0.58 (9.5)	5.61 (92)	22.94 (376)	6.98 (114.3)	8.32 (136.4)	13.669-13.666 (224.00-223.95)	12.81 (209.9)	10.73 (175.8)	22.19 (363.7)
P16	19.02 (311.7)	18.75 (307.3)	0.63 (10.3)	—	14.66 (240.2)	4.5 (73.7)	5.5 (90.1)	6.500-6.498 (106.52-106.48)	8.43 (138.1)	7.27 (119.1)	14.57 (238.8)
P260	29.85 (489.2)	29.43 (482.3)	0.58 (9.5)	5.61 (92)	22.73 (372.4)	6.98 (114.3)	8.91 (146.0)	15.256-15.254 (250.00-249.96)	13.07 (214.2)	11.28 (184.8)	22.59 (370.2)

\*A1 = without rear drive, A2 = with rear drive

# Piston Pumps

## Premier Model Ordering Code

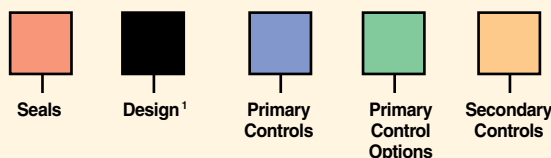
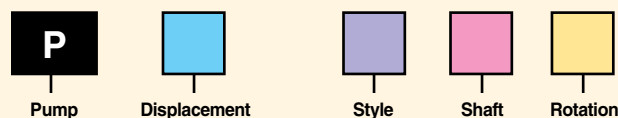

Code	Displacement
05	4.90 in <sup>3</sup> /rev (80.3 cc/rev)
07	6.70 in <sup>3</sup> /rev (109.8 cc/rev)
09	8.60 in <sup>3</sup> /rev (140.9 cc/rev)
12	12.20 in <sup>3</sup> /rev (200.0 cc/rev)
16	16.00 in <sup>3</sup> /rev (262.2 cc/rev)
080	4.90 in <sup>3</sup> /rev (80.3 cc/rev)
110	6.70 in <sup>3</sup> /rev (109.8 cc/rev)
140	8.60 in <sup>3</sup> /rev (140.9 cc/rev)
200	12.20 in <sup>3</sup> /rev (200.0 cc/rev)
260	16.00 in <sup>3</sup> /rev (262.2 cc/rev)

Code	Style
H	High Speed (> 1800 RPM) – P16, P260, P12, P200, P09 & P140 only
Q	High Speed (≤ 1800 RPM) – P16, P260, P12, P200, P09 & P140 only
Omit	P07, P110, P05 & P080

Code	Shaft
2	Keyed – SAE or ISO
3	Splined – SAE or ISO
5	Splined – SAE High Torque (P16 only)
6	Keyed – DIN (metric pumps only) – DIN 40mm for sizes 080 & 110 DIN 50mm for sizes 140 & 200 DIN 60mm for size 200
7	Splined – DIN (metric pumps only) DIN 40mm for sizes 080 & 110 DIN 50mm for sizes 140 & 200 DIN 60mm for size 200
8	Keyed – DIN (DIN 60mm for size 200 only)
9	Splined – DIN (DIN 60mm for size 200 only)

Code	Rotation
R	Clockwise
L	Counterclockwise

Code	Seals
1	Nitrile (Buna-N)
4	EPR <sup>2</sup>
5	Fluorocarbon

Code	Primary Controls
C	Compensator
L	Load Sensing Compensator (50 PSI (3.4 BAR) Pressure Drop)
M	Load Sensing Compensator (200 PSI (13.8 BAR) Pressure Drop)
R	Rotary Servo
H	Hydraulic Servo
E	Electrohydraulic Servo**
J	Low Torque Limiter
K	High Torque Limiter
V	Load Sensing (L) + Low Torque Limiter (J)
W	Load Sensing (L) + High Torque Limiter (K)
Y	Load Sensing (M) + Low Torque Limiter (J)
Z	Load Sensing (M) + High Torque Limiter (K)

Code	Primary Control Options
1	Max. Volume Screw without Indicator
2	Handwheel Max. Volume Control without Indicator (not available w/R, H, E & X primary controls)
3	Max. Volume Screw with Potentiometer**
4	Max. Volume Screw with LVDT**
5	Max. Volume Screw with Mechanical Cam Angle Indicator
6	Handwheel Max. Volume Control with Potentiometer** (not available with R, H, E & X primary controls)
7	Handwheel Max. Volume Control with LVDT** (not available with R, H, E & X primary controls)
8	Handwheel Max. Volume Control with Mechanical Cam Angle Indicator (not available w/R, H, E & X primary controls)

Code	Secondary Controls
0	None
P	Compensator Override (for E, H & R primary controls only)
J	Low Torque Limiter Override (for E, H & R primary controls only)
K	High Torque Limiter Override (for E, H & R primary controls only)

1 Assigned by manufacturer.  
2 Not approved for ATEX applications.





# Piston Pumps

## Premier Model Ordering Code



External Drive



External Mounting



Special Modifications

Code	External Drive
0	None
M	Rear Blanking Plate
A	SAE-A (SAE 82-2) with SAE-A (SAE 16-4) Coupling
G	SAE-A (SAE 82-2) with SAE-B (SAE 22-4) Coupling
B	SAE-B (SAE 101-2 & SAE 101-4) with SAE-B (SAE 22-4) Coupling
Q	SAE-B (SAE 101-2 & SAE 101-4) with SAE-BB (SAE 25-4) Coupling
C	SAE-C (SAE 127-2 & SAE 127-4) with SAE-C (SAE 32-4) Coupling
N	SAE-C (SAE 127-2 & SAE 127-4) with SAE-CC (SAE 38-4) Coupling
D	SAE-D (SAE 152-2 & SAE 152-4) with SAE-D & SAE-E (SAE 44-4) Coupling
E	SAE-E (SAE 165-2 & SAE 165-4) with SAE-D & SAE -E (SAE 44-4) Coupling – P12/200 & P16/260 only
T	ISO 180 B4HW Flange, K40N Coupling
U	ISO 180 B4HW Flange, K50N Coupling
L	ISO 180 B4HW Flange, DIN 40-18 Coupling – P16/260 only
S	ISO 180 B4HW Flange, DIN 50-24 Coupling – P16/260 only
R	ISO 224 B4HW Flange, K50N Coupling – P12/200 & P16/260 only
V	ISO 250 B4HW Flange, K50N Coupling – P16/260 only
W	ISO 200 B4HW Flange, K50N Coupling – P12/200 & P26/260 only
X	ISO 160 B4HW Flange, K40N Coupling
Y	ISO 125 B4HW Flange, K32N Coupling
Z	ISO 100 B4HW Flange, K25N Coupling

Code	External Mounting
0	No External Pump Mounted
1	External Pump Mounted (must be separately specified) – Requires Special Modification “-M2”

Code	Special Modifications
Omit	None
NP	No Paint <sup>3</sup>
EX	ATEX APPROVED PUMP (May include additional modifications.)
M2	Other Special Modification (example: bronze caged barrel bearing for low viscosity fluids, mechanical shaft seal, hydrostatic cam, tandem pumps, etc.) <sup>3</sup>

<sup>3</sup> These options are not approved for ATEX applications.

### Allowable Controls \*\*

Primary Control	Primary Option Plus Secondary Control																			
	10	20	30	40	50	60	70	80	1P	3P	4P	5P	1J	3J	4J	5J	1K	3K	4K	5K
C	•	•	•	•	•	•	•	•												
E	•		•	•	•				•	•	•	•	•	•	•	•	•	•	•	•
H	•		•	•	•				•	•	•	•	•	•	•	•	•	•	•	•
J	•	•	•	•	•	•	•	•												
K	•	•	•	•	•	•	•	•												
L	•	•	•	•	•	•	•	•												
M	•	•	•	•	•	•	•	•												
R	•		•	•	•				•	•	•	•	•	•	•	•	•	•	•	•
V	•	•	•	•	•	•	•	•												
W	•	•	•	•	•	•	•	•												
Y	•	•	•	•	•	•	•	•												
Z	•	•	•	•	•	•	•	•												

\*\* The following control options are not available for ATEX 94/9EC: Electrohydraulic Servo (E\*\*) and use of either potentiometer or LVDT position feedback (\*3\*, \*4\*, \*6\*, \*7\*)

= Omit if not required

# Piston Pumps (Mobile)



## VP1 Load Sensing Truck Pumps



The VP1 is the world's first variable displacement pump for truck applications. It can be close-coupled to a gearbox PTO (power take-off) or to a coupling independent PTO (e.g. an engine PTO) which meets ISO standard 7653-1985.

- Variable displacement
- Low noise level
- High power-to-weight ratio
- Compact and lightweight
- Highly efficient
- Sturdy design
- Withstands low temperatures
- Can be close coupled and tandem mounted

## Pump Performance Data

Model Series	Max. Displacement in <sup>3</sup> /rev (cc/rev)	Outlet Pressure PSI (BAR)	Drive Speed RPM	Flow @ Rated RPM GPM (LPM)	Max. Horsepower HP (KW)
VP1-45	2.75 (45)	4350 (300)	2400	26 (98.4)	80 (59.7)
VP1-75	4.58 (75)	4350 (300)	2100	39 (147.6)	120 (89.5)
VP1-120	7.32 (120)	4350 (300)	1800	53 (200.6)	165 (123.0)

## Markets

Forestry	Knuckle Boom Loader, Cranes
Construction	Off-Highway Trucks, Fan Drives
Mining	Dump Trucks
Material Handling	Truck Mounted Cranes, Lift Trucks
Recycling	Vacuum Truck Systems, Refuse Trucks - ASL, Rear Loaders
Military	Fan Drives

## Applications

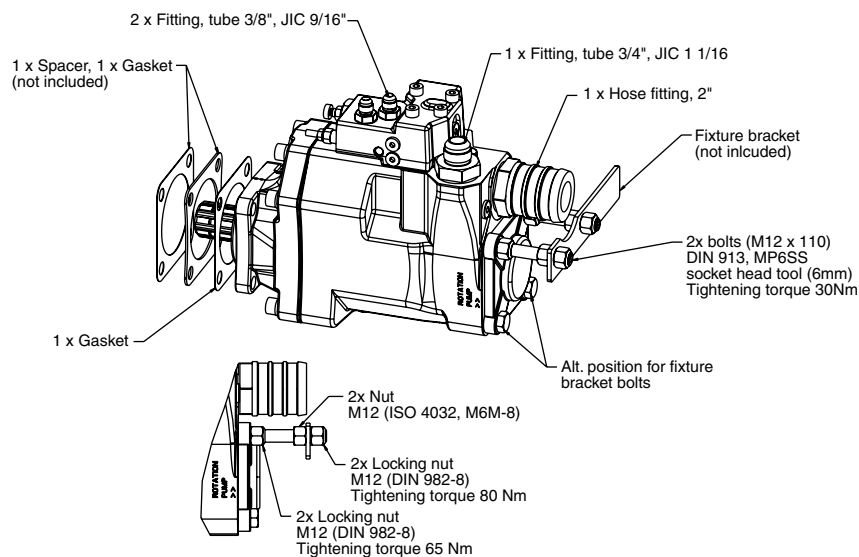

Note: Complete Mounting and Fitting Kit available as part number dwg of kit 3785286. Contains BSP to JIC fittings for suction, pressure, load sense and drain lines along with studs for rear support and optional PTO shim plate with extra gasket.

## VP1 Load Sensing Truck Pumps

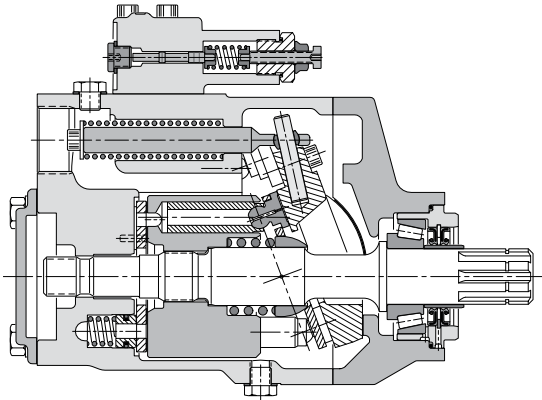

### Benefits/Features

- Thru-drive capability on VP1-045 and VP1-075
- Higher self-priming speeds
- Operating pressures to 5801.51 PSI (400 BAR)
- New frame sizes to meet market requirements
- Higher overall efficiency
- Increased reliability
- Reduced noise level
- Smaller installation dimensions

### Control

- Load sense and pressure limiter

### Control Performance

- Data on response

### Thru-drive

- Fitting Kit 3797795 will accommodate mounting a DIN 5462 pump to the rear of the VP1. Check the factory for torque limitations on rear mount.

## VP1 Load Sensing Truck Pumps

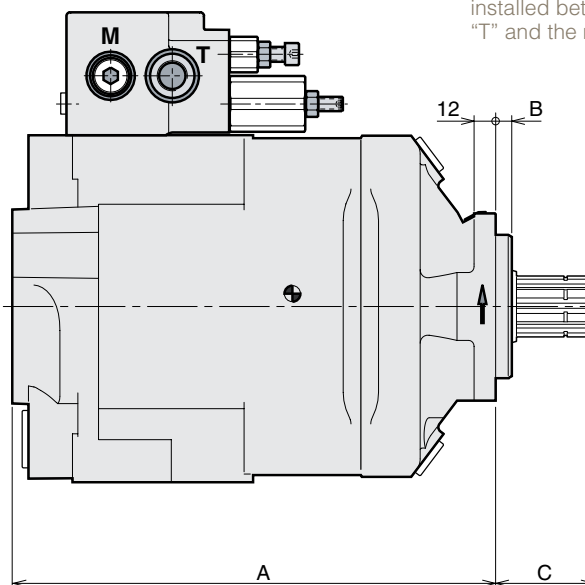
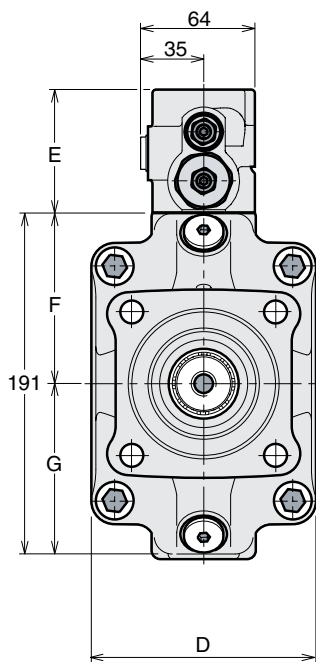
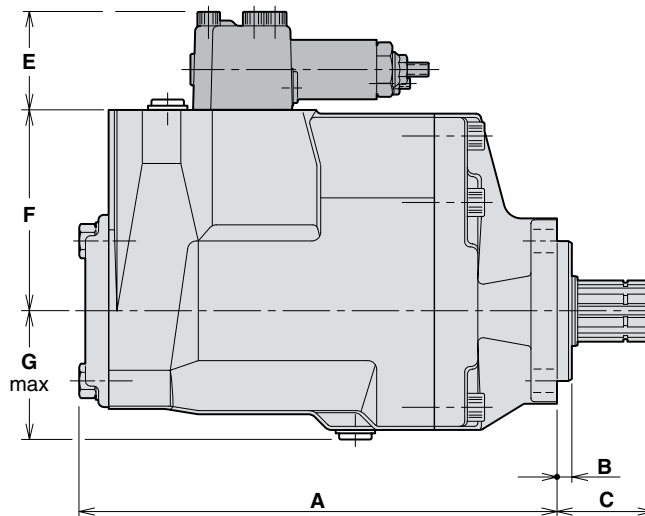
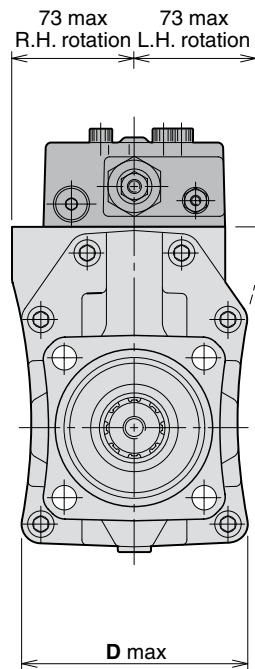

**IMPORTANT!**  
The control is not drained through the pump case. An external line must be installed between the control drain port "T" and the reservoir.

### Dimensions, inch (mm)

Series	A max	B	C	D max	E	F	G max	H max
VP1-045 VP1-075	10.89 (276.5)	0.33 (8.5)	2.17 (55)	5.20 (132)	2.20 (56)	4.53 (115)	2.80 (71)	2.87 (73)
VP1-120	10.59 (269)	0.35 (9)	2.17 (55)	4.92 (125)	2.68 (68)	3.78 (96)	3.74 (95)	—



# Piston Pumps

## VPI Model Ordering Code

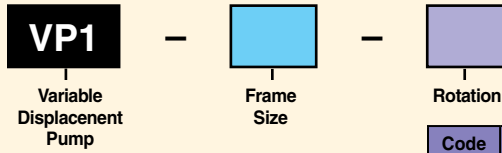

Code	Frame Size
045	2.75 in <sup>3</sup> /rev (45 cc/rev)
075	4.58 in <sup>3</sup> /rev (75 cc/rev)
120	7.32 in <sup>3</sup> /rev (120 cc/rev)

Code	Rotation
L	Left Hand (CCW)
R	Right Hand (CW)

- NOTES:**
1. All fittings must be ordered separately.
  2. Use seven digit number when placing order.
  3. Fitting Kit 378 5286 provides adapter fittings for inlet /outlet,

Ordering Code	Ordering No.
VP1-045-R	378 0334
VP1-045-L	378 0335
VP1-075-R	378 0336
VP1-075-L	378 0337
VP1-120-R	378 3182
VP1-120-L	378 3183

load sense and drain ports to JIC connections, along with the mounting gasket and support studs for installation.

### Fitting Kits

Each kit consists of a pressure fitting, a suction fitting and corresponding seal washers.

#### Kits with straight suction fitting

Ordering no.	C <sub>1</sub>	C <sub>2</sub> dia.
370 4936	BSP ¾" (19.1mm)	2" (50.8mm)
370 7220*	BSP 1" (25.4mm)	2" (50.8mm)

\* Above 100 l/min

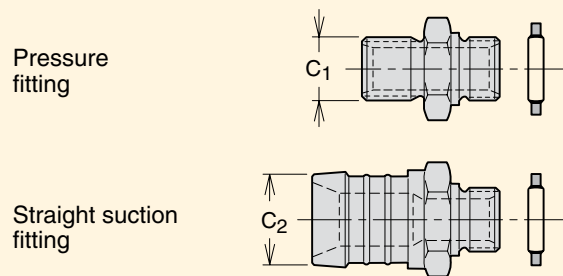

#### Kits with 45° suction fitting

Ordering no.	A in. (mm)	B in. (mm)	C <sub>1</sub>	C <sub>2</sub> dia.
379 9563	2.80 (71)	6.06 (154)	BSP ¾" (19.1mm)	2" (50.8mm)
379 9562*	2.52 (64)	5.79 (147)	BSP 1" (25.4mm)	2½" (63.5mm)

\* Above 100 l/min

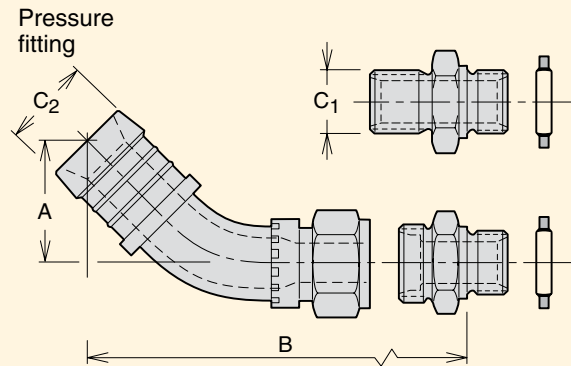

45° adjustable suction fitting

#### Kits with 90° suction fitting

Ordering no.	A in. (mm)	B in. (mm)	C <sub>1</sub>	C <sub>2</sub> dia.
379 9918	5.67 (144)	5.04 (128)	BSP 1" (25.4mm)	2" (50.8mm)

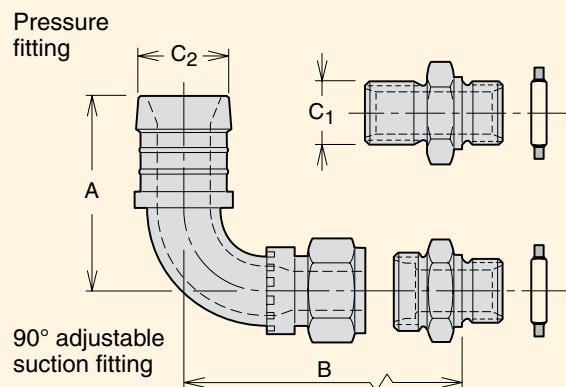

90° adjustable suction fitting

## PAVC Medium Pressure/Super Charged Piston Pumps



PAVC piston pumps are ideal for many applications with operating pressure up to 3000 PSI (210 BAR). These compact pumps feature convenient cartridge style controls and carry a full pressure rating on most water glycol fluids.

- High strength cast-iron housing
- Built-in supercharger
- High speed capability - 3000 RPM (2600 RPM PAVC100)
- Sealed shaft bearing

- Two piece design for ease of service
- Cartridge bronze clad port plate
- Airbleed standard for quick priming
- Hydrodynamic cylinder barrel bearing
- Thru-shaft (PAVC100 only)
- Full pressure rating on water glycol fluids
- Pump case and shaft seal - see inlet pressure only
- Filter and/or cool drain line (100 PSI Max.) (6.9 BAR Max.)

### Pump Performance Data

Model Series	Max. Displacement in <sup>3</sup> /rev (cc/rev)	Rated Outlet Pressure PSI (BAR)	Drive Speed RPM	At MAX RPM and 3000 PSI	
				Flow GPM (LPM)	Input Horsepower HP (KW)
PAVC33	2.01 (33)	3000 (210)	3000	25 (94.6)	50 (37.3)
PAVC38	2.32 (38)	3000 (210)	3000	28 (106.0)	55 (41.0)
PAVC65	3.97 (65)	3000 (210)	3000	52 (196.8)	96 (71.6)
PAVC100	6.10 (100)	3000 (210)	2600	69 (261.2)	140 (104.4)





# Piston Pumps (Mobile & Industrial)

## PAVC Medium Pressure/Super Charged Piston Pumps

### Performance Characteristics

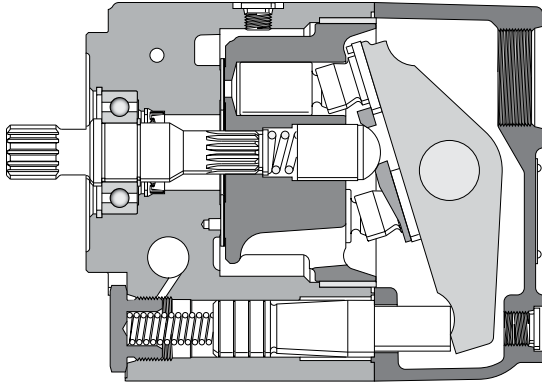

### Benefits/Features

- High strength cast-iron housing
- Built-in supercharger ensures high speed capability - 3000 RPM (2600 RPM PAVC100)
- Sealed shaft bearing
- Two-piece design for ease of service
- Cartridge type controls field changeable
- Replaceable bronze clad port plate
- Airbled standard for quick priming
- Hydrodynamic cylinder barrel bearing
- Thru-shaft (PAVC100 only)
- Full pressure rating on most water glycol fluids
- Pump case and shaft seal are subjected to inlet pressure only
- Filter and/or cool drain line 100 PSI (7 BAR) maximum

### Controls

- Pressure compensation
- Load sensing
- Power (torque) limiting
- Power and load sensing
- Remote pressure compensation
- Adjustable maximum volume stop
- Low pressure standby

**PAVC Series Shaft Input Power - 2000 RPM**

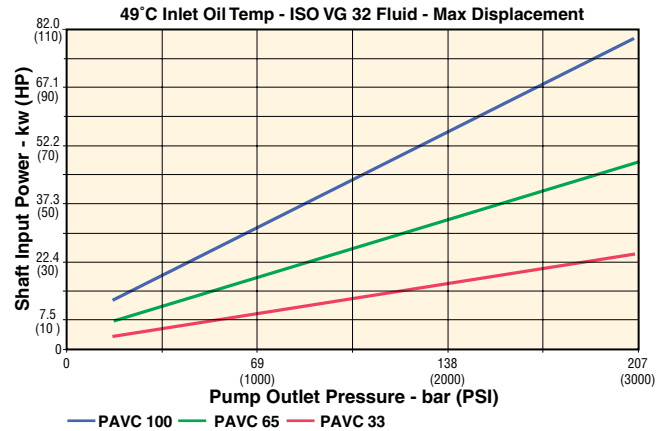

**PAVC Series Pump Outlet Flow - 2000 RPM**

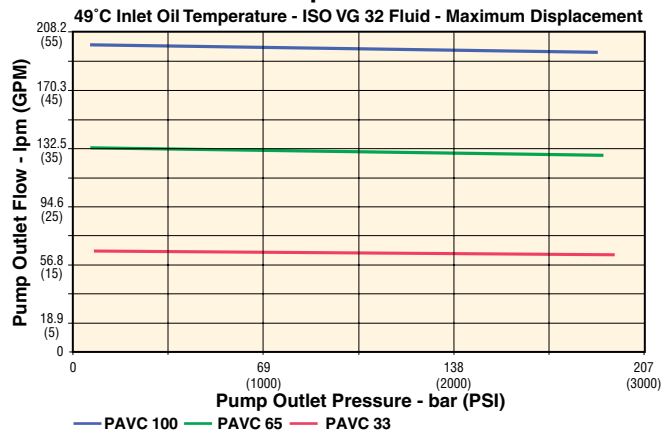

**PAVC Series Overall Efficiency - 2000 RPM**

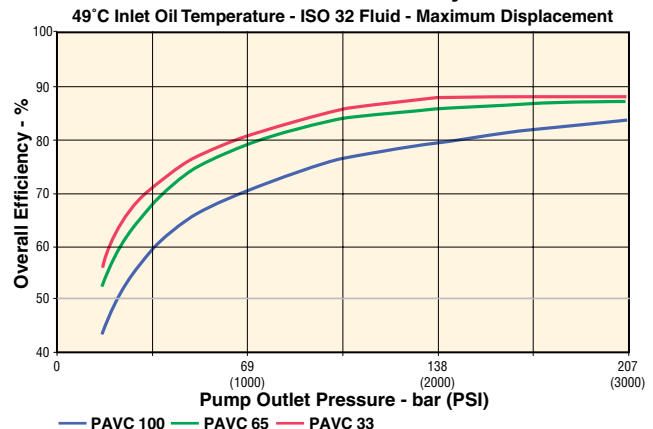

## PAVC Medium Pressure/Super Charged Piston Pumps

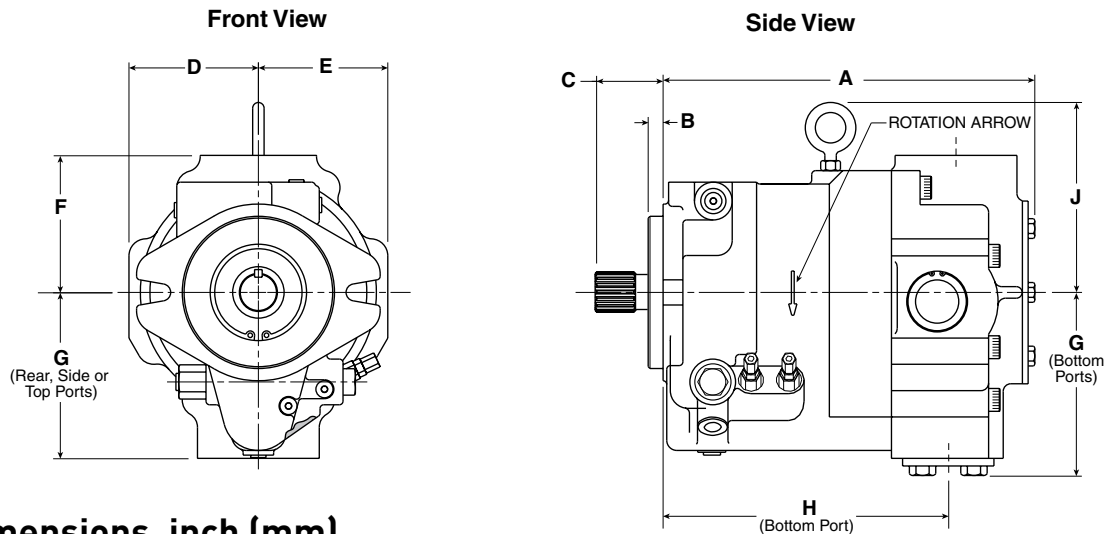

### Dimensions, inch (mm)

Dim.	PAVC33/38		PAVC65		PAVC100	
	Rear Ported	Side Ported	Rear Ported	Top Ported	Rear Ported	Top/Bottom Ported
<b>A</b>	7.25 (184.15)	7.32 (185.93)	8.82 (224.03)	8.82 (224.02)	11.95 (303.53)	12.21 (310.13)
<b>B</b>	0.37 (9.39)	0.37 (9.37)	0.49 (12.45)	0.49 (12.44)	0.49 (12.44)	0.49 (12.44)
<b>C</b>	2.31 (58.67)	2.31 (58.67)	2.19 (55.63)	2.19 (55.62)	2.19 (55.62)	2.19 (55.62)
<b>D</b>	3.31 (84.07)	4.17 (105.92)	4.00 (101.60)	4.00 (101.60)	4.25 (107.95)	4.25 (107.94)
<b>E</b>	3.31 (84.07)	3.53 (89.66)	4.00 (101.60)	4.00 (101.60)	4.25 (107.95)	4.25 (107.94)
<b>F</b>	2.50 (63.50)	2.50 (63.50)	3.50 (88.90)	3.38 (85.85)	4.62 (117.34)	4.50 (114.30)
<b>G</b>	3.81 (96.77)	4.12 (104.65)	4.56 (115.82)	4.56 (115.82)	5.57 (141.47)	6.25 (159.25)
<b>H</b>	—	—	—	—	—	9.37 (237.99)
<b>J</b>	—	—	—	—	6.24 (158.49)	6.24 (159.49)

### PAVC100 SAE B, SAE BB and SAE C Thru-drive Kits

Pump Series	Mount	Spline	Kit #
PAVC 100...6B3	SAE B	SAE B	787076
PAVC 100...6B4	SAE B	SAE BB	787077
PAVC 100...6C3	SAE C	SAE C	787076

Note: Pumps can be converted from/to SAE B, BB or SAE C thru-drives by using the kits listed.



# Piston Pumps

## PAVC Model Ordering Code

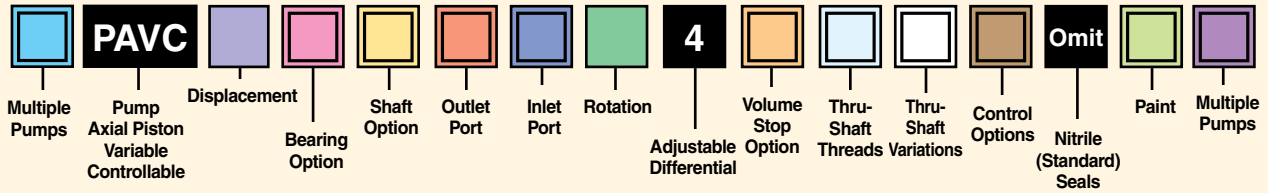

Code	Multiple Pumps
Omit	Single Pump
—	Factory Mounted to Rear of Another Pump

Code	Displacement in <sup>3</sup> /rev (cm <sup>3</sup> /rev)
33	2.0 (33)
38	2.3 (38)
65	4.0 (65)
100	6.1 (100)

Code	Bearing Option
Omit	Single Piece Shaft
9*	Dual Bearing

\* For applications where side loading may be experienced. Max. side load = 113.4 kg (250 lbs).

**Typical Applications:**  
 Belt/chain drive  
 Universal joint drive  
 Massive couplings  
 Foot mount installations

Code	Shaft Option	
	Size 33/38	Size 65/100
Omit	7/8" Keyed SAE B	1¼" Keyed SAE C
B	13T Spline SAE B	14T Spline SAE C
C*	—	1½" Keyed SAE CC
D*	—	17T Spline SAE CC

\* Size 100 only

Code	Outlet Port		
	Outlet	Location	Type
Omit	Str. Thread	Top	SAE/Inch
3*	Flange	Top	SAE/Inch

\* Size 100 only

Code	Inlet Port			
	33/38 Inlet	65 Inlet	100 Inlet	Type
Omit	Str. Thd., Rear	Str. Thd., Rear	Flange, Rear	SAE/Inch Threads
2	Flange, Side	Flange, Top	Flange, Top/Bottom	SAE/Inch Threads

Code	Rotation*
R	Right CW
L	Left CCW

\* Viewed from shaft end.

Code	Volume Stop Options
Omit	Volume Stop Plugged
2	Maximum Volume Stop
5*	Max. Volume Stop with O-ring

\* Not available with Thru-Shaft option on Size 100.

Code	Thru-Shaft Threads*
Omit	No Thru-Shaft
6	Thru-Shaft, UNC

\* Available on Size 100 only.

Code	Thru-Shaft Variations
Omit	No Thru-Shaft Option
A3	Thru-Shaft, SAE AA Pilot, 9 Tooth 20/40 Pitch Spline Coupling, PAVC 100 Only
A4	Thru-Shaft, SAE A Pilot, 9 Tooth 16/32 Pitch Spline Coupling, PAVC 100 Only
*B3	Thru-Shaft, SAE B Pilot, 13 Tooth 16/32 Pitch Spline Coupling, PAVC 100 Only
*B4	Thru-Shaft, SAE B Pilot, 15 Tooth 16/32 Pitch Spline Coupling, PAVC 100 Only
*C3	Thru-Shaft, SAE C Pilot, 14 Tooth 12/24 Pitch Spline Coupling, PAVC 100 Only

Inlet port option "2" or "8" (top/bottom) must be used with all Thru-Shaft pumps.

\* Use SAE C-C shaft on thru-shaft pump variation when combined input torque of front and rear pumps exceeds 565 N•m (5000 In-Lbs).

Code	Control Option
Omit	Standard Pressure Compensated Setting Pressure 41-207 bar (600-3000 PSI)
A	Pressure & Flow (Load Sensing)
*C	Pressure, Flow & Power
*H	Pressure Comp. & Power
**†M	Remote Pressure
**†ME	Remote Pressure
†AM	Remote Pressure & Flow
††CM	Remote Pressure, Flow & Power
††HM	Remote Pressure & Power

\* Power controlled pumps (H, C, HM or CM) must have maximum input power limit specifications at a particular drive speed (RPM) and compensator pressure setting (PSI) included with order. Power controlled pumps that do not have input power limit specifications, will be set at default setting (22.5 HP @ 1800 RPM and 3000 PSI) "H" & "C" (60 HP @ 1800 RPM and 3000 PSI) "HM" & "CM"

\*\* "M" may be remotely controlled; "ME" requires external pilot

† Pumps with M, ME, AM, CM or HM controls will be set to compensate at 207 bar (3000 PSI) unless Chart #1 specifies otherwise.

Code	Painting
Omit	No Paint
P	Paint

Code	Multiple Pumps
Omit	Single Pump
—	Pump Factory Mounted on Rear

### Chart #1

Item	Setting
RPM	—
PSI	—
HP	—
GPM	—

### Ordering Notes

Unless otherwise specified, pump is shipped at maximum GPM (1800 RPM) and set to 69 bar (1000 PSI) [See † Exceptions].

When factory settings are required, the items shown in Chart #1 must be included with order.

= Omit if not required or to select standard option coded "omit".

## F11 Small Frame Fixed Displacement Bent-Axis Pumps



F11 is a well proven bent axis, fixed displacement heavy-duty pump Series. They can be used in open or closed circuit applications where high efficiency, high drive speeds, high pressure and indirect drives are desired. The F11 will provide high output flows in a very compact package.

### Pump Performance Data

Model Series	Displacement in <sup>3</sup> /rev (cc/rev)	Continuous Pressure PSI (BAR)	Rated Speed RPM	Flow @ Rated RPM GPM (LPM)
F11005	0.30 (4.9)	5000 (350)	4600	5.5 (20.8)
F11006	0.37 (6.0)	5000 (350)	4200	6.6 (25.0)
F11010	0.60 (9.8)	5000 (350)	4200	11 (41.6)
F11012	0.76 (12.5)	5000 (350)	3850	12.5 (47.3)
F11014	0.87 (14.3)	5000 (350)	3900	14 (53.0)
F11019	1.16 (19.0)	5000 (350)	3500	17 (64.4)

### Markets

### Applications

Forestry	Saw Drives, Feller Bunchers, Skidder, Forwarder, Cranes, Mowers / Cutters
Industrial	Aircraft Test Stands
Marine	Deck Cranes, Constant Tension Winches, Hatch Covers
Oil & Gas	Nitrogen Pumpers, Frac Trucks, Coil Tubing
Construction	Skid Steer, Off-Highway Trucks, Fan Drives, Cranes, Dust Collector, Excavator
Mining	Drill Rigs, Top Drives, Loaders, Subsurface Loaders, Tunneling Equipment
Material Handling	Conveyor Drives, Truck Mounted Cranes, Mixers
Recycling	Shredders, Vacuum Truck Systems
Military	Fan Drives

## F11 Small Frame Fixed Displacement Bent-Axis Pumps/Motors

### Performance Characteristics

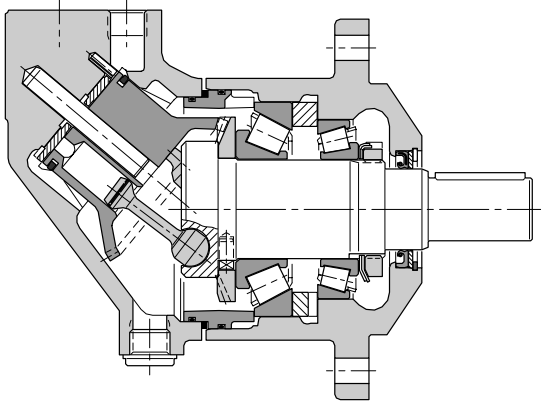

F11 Series Overall Efficiency

Pump - 250 bar (3625 PSI)

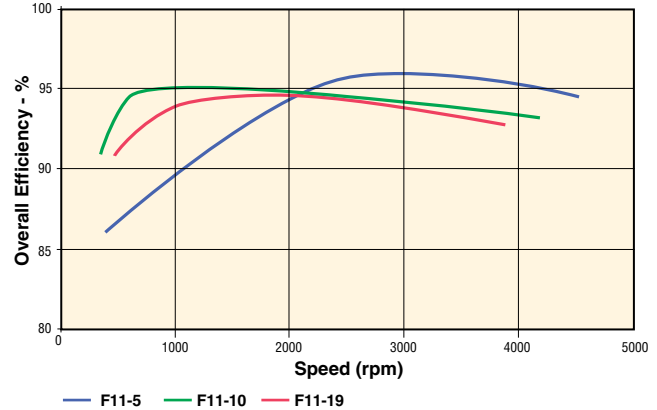

### Benefits/Features

- F11 fixed pumps can be used at unusually high shaft speeds
- Intermittent operating pressures to 6000 PSI (413.7 BAR)
- Compact, lightweight pump, high power to weight ratio
- Laminated piston ring provides low internal leakage and thermal shock resistance
- F11 Series have very few moving parts providing long life and service friendly design
- Heavy duty roller bearings for indirect drive

## F11 Small Frame Fixed Displacement Bent-Axis Pumps/Motors

**F11-14**  
(SAE versions)

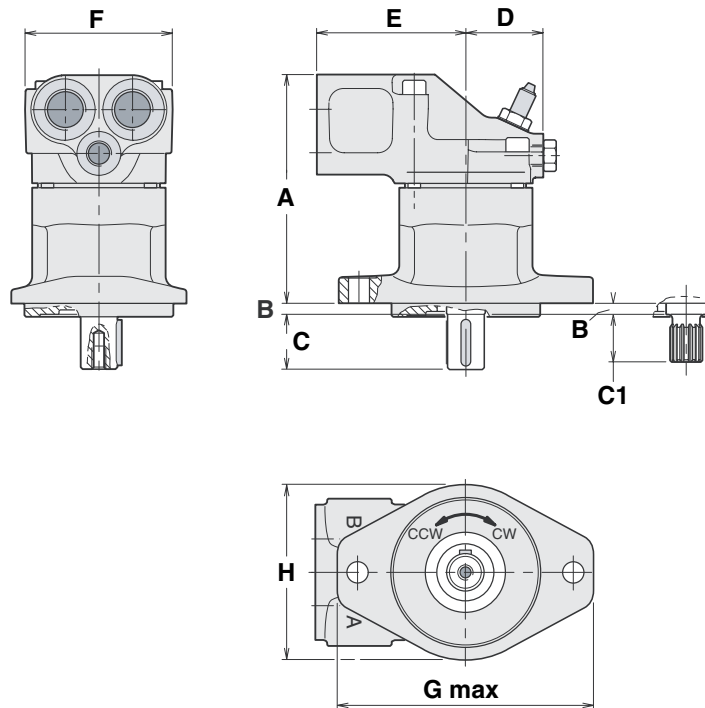

### Dimensions, inch (mm)

Series	A max	B	C	C1	D	E	F	G max	H
F11-05	5.28 (134.1)	.31 (7.8)	1.57 (39.9)	0.39 (8.89)	1.87 (47.5)	2.56 (65.0)	3.31 (84.1)	5.0 (127.0)	3.78 (96.0)
F11-06	6.21 (175.7)	0.31 (7.9)	1.50 (38.1)	1.30 (33.0)	2.09 (53.1)	4.02 (102.1)	3.98 (101.1)	6.85 (174.0)	4.72 (119.9)
F11-10	6.21 (175.7)	0.31 (7.9)	1.50 (38.1)	1.30 (33.0)	2.09 (53.1)	4.02 (102.1)	3.98 (101.1)	6.85 (174.0)	4.72 (119.9)
F11-12	6.14 (156.0)	.55 (14.0)	1.97 (50.0)	.87 (22.1)	2.09 (53.1)	4.02 (102.1)	3.98 (101.1)	5.98 (151.9)	4.57 (116.1)
F11-14	6.21 (175.7)	0.31 (7.9)	1.50 (38.1)	1.30 (33.0)	2.09 (53.1)	4.02 (102.1)	3.98 (101.1)	6.85 (174.0)	4.72 (119.9)
F11-19	7.13 (181.1)	0.31 (7.9)	1.50 (38.1)	1.30 (33.0)	2.48 (63.0)	3.46 (87.9)	4.49 (114.0)	6.93 (176.0)	4.84 (122.9)



# Piston Pumps

## F11 Model Ordering Code

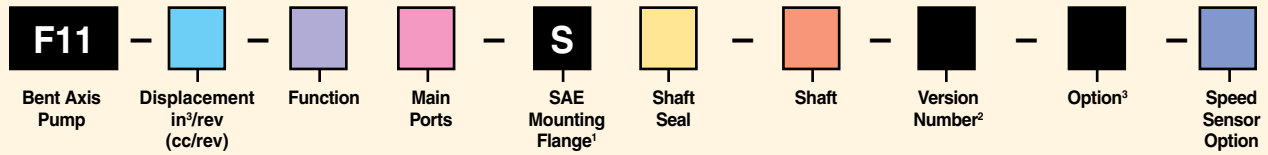

Code	Displacement in³/rev (cc/rev)
005*	0.30 in³/rev (4.9 cc/r)
010*	0.60 in³/rev (9.8 cc/r)
012*	0.76 in³/rev (12.5 cc/r)
014	0.87 in³/rev (14.3 cc/r)
019	1.16 in³/rev (19.0 cc/r)

\* ISO or CETOP mounting options, see catalog on CD

Code	Function	005	010	012	014	019
R	Pump, CW Rotation	x	x	x	x	x
L	Pump, CCW Rotation	x	x	x	x	x

Code	Main Ports	005	010	012	014	019
U	SAE, UN Threads	x	x	—	x	x
B	BSP Threads	x	x	x	—	x
F	SAE 6000 PSI Flange*	—	x	x	x	—

\* Metric threads

x: Available —: Not Available

¹CETOP and ISO mounting also available. See catalog on CD.

²Assigned by factory for special versions

³None (see catalog on CD)

Code	Shaft Seal	005	010	012	014	019
N	NBR*, Low Pressure	x	x	—	—	x
V	FPM**, High Pressure, High Temperature	x	x	x	x	x

\* NBR - Nitrile rubber

\*\* FPM - Fluorocarbon rubber

Code	Shaft	005	010	012	014	019
T	SAE Key	—	—	—	x	x
S	SAE Spline	x	x	x	x	x
K	Metric Key	x	x	x	x	x
D	DIN 5480 Spline	x	x	x	x	x

Code	Speed Sensor	005	010	012	014	019
P	Prepared for Speed Sensor	—	—	x	x	x

Order speed sensor kit# 3785190 separately



## F12 Large Frame Fixed Displacement Bent-Axis Pumps



F12 is a high performance, bent axis, fixed displacement heavy-duty pump series. They can be used in numerous applications where high efficiency, high drive speeds, high pressure and indirect drives are desired. The F12 will provide high output flows in a very compact package.

### Pump Performance Data

Model Series	Displacement in <sup>3</sup> /rev (cc/rev)	Continuous Pressure PSI (BAR)	Rated Speed RPM	Flow GPM (LPM)
F12-030	1.83 (30.0)	6000 (420)	3150	23 (87.1)
F12-040	2.44 (40.0)	6000 (420)	2870	28 (106.0)
F12-060	3.64 (59.6)	6000 (420)	2500	37 (140.1)
F12-080	4.91 (80.4)	6000 (420)	2300	46 (174.1)
F12-090	5.68 (93.0)	6000 (420)	2300	53.5 (202.5)
F12-110	6.72 (110.1)	6000 (420)	2290	63 (238.5)
F12-125	7.63 (125.0)	6000 (420)	2290	72 (272.5)
F12-150	9.15 (150.0)	5000 (350)	3200	103 (389.9)
F12-250	14.77 (242.0)	5000 (350)	2700	154 (583.0)

### Markets

### Applications

Forestry	Saw Drives, Feller Bunchers, Skidder, Forwarder, Cranes, Mowers / Cutters
Industrial	Aircraft Test Stands
Marine	Deck Cranes, Constant Tension Winches, Hatch Covers
Oil & Gas	Nitrogen Pumpers, Frac Trucks
Construction	Skid Steer, Off-Highway Trucks, Fan Drives, Cranes, Dust Collector, Excavator
Mining	Drill Rigs, Top Drives, Loaders, Subsurface Loaders, Tunneling Equipment
Material Handling	Conveyor Drives, Truck Mounted Cranes, Mixers
Recycling	Shredders, Vacuum Truck Systems
Military	Fan Drives

## F12 Large Frame Fixed Displacement Bent-Axis Pumps

### Performance Characteristics

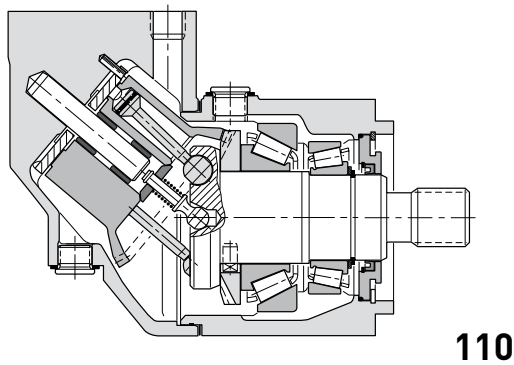
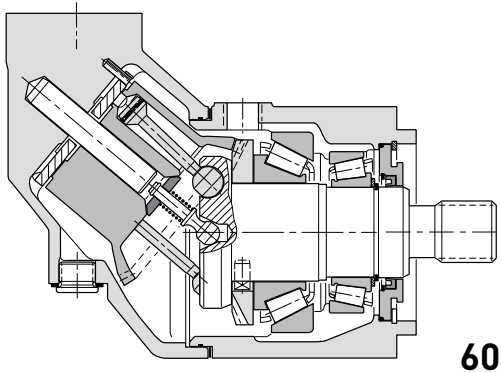

### Benefits/Features

- Intermittent operating pressures to 7000 PSI (482.6 BAR)
- Compact, lightweight pump with high power to weight ratio
- Laminated piston ring provides low internal leakage and thermal shock resistance
- F12 Series have very few moving parts providing long life and service friendly design
- Heavy duty roller bearings provide indirect drive capability

**F12 Series Overall Efficiency**

Pump - 420 bar (6092 PSI)

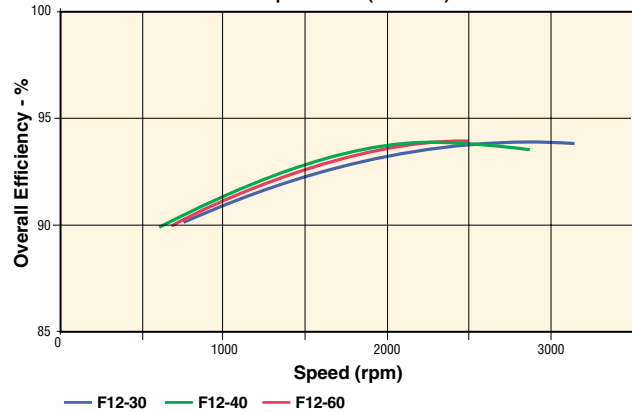

**F12 Series Overall Efficiency**

Pump - 420 bar (6092 PSI)

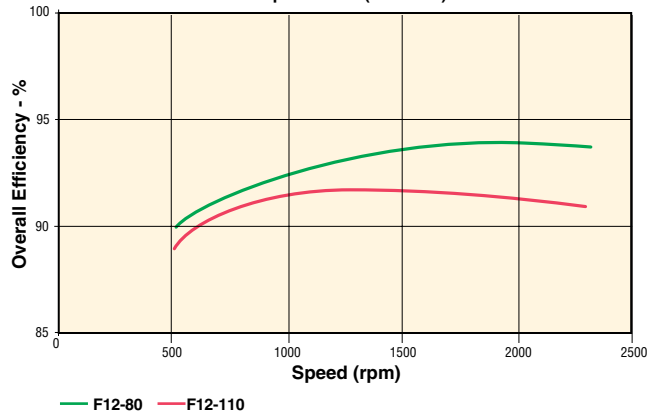

**F12 Series Overall Efficiency**

Motor - 250 bar (3625 PSI)

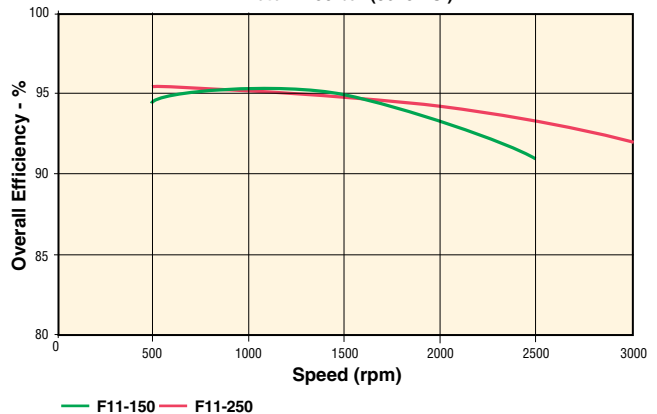

## F12 Large Frame Fixed Displacement Bent-Axis Pumps

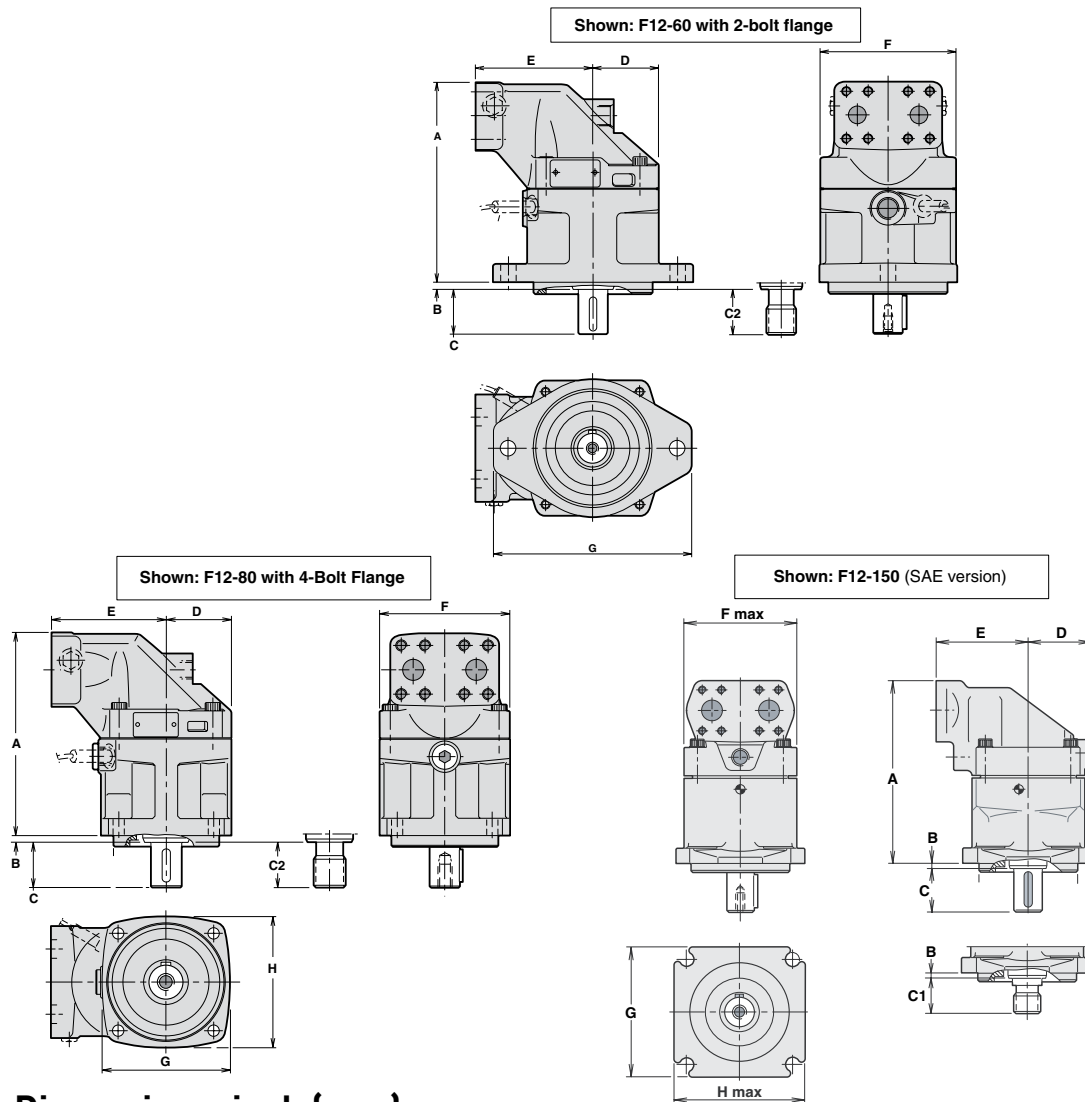

### Dimensions, inch (mm)

Series 2-BOLT	A	B	C	C2	D	E	F	G
F12-30	7.46 (189.5)	0.31 (7.9)	1.5 (38.1)	1.3 (33.0)	2.32 (58.9)	3.94 (100.1)	4.80 (121.9)	6.93 (176.0)
F12-40	7.76 (197.1)	0.31 (7.9)	1.89 (48.0)	1.89 (48.0)	2.56 (64.0)	4.33 (110.0)	5.28 (134.1)	8.46 (214.9)
F12-60	8.43 (214.1)	0.31 (7.9)	1.89 (48.0)	1.89 (48.0)	2.76 (70.1)	4.92 (125.0)	5.67 (144.0)	8.46 (214.9)

Series 4-BOLT	A	B	C	C2	D	E	F	G	H
F12-30	7.46 (189.5)	0.31 (7.9)	1.50 (38.1)	1.30 (33.0)	2.32 (58.9)	3.94 (100.1)	4.80 (121.9)	4.65 (118.1)	4.65 (118.1)
F12-40	7.76 (197.1)	0.31 (7.9)	1.89 (48.0)	1.89 (48.0)	2.56 (65.0)	4.33 (110.0)	5.28 (134.1)	5.83 (148.1)	5.67 (144.0)
F12-60	8.43 (214.1)	0.31 (7.9)	1.89 (48.0)	1.89 (48.0)	2.76 (70.1)	4.92 (125.0)	5.67 (144.0)	5.83 (148.1)	5.67 (144.0)
F12-80	9.45 (240.0)	0.31 (7.9)	2.13 (54.1)	2.13 (54.1)	3.05 (77.5)	5.31 (134.9)	6.10 (154.9)	6.10 (154.9)	6.10 (154.9)
F12-110	10.39 (263.9)	0.31 (7.9)	2.64 (67.1)	2.63 (66.8)	3.35 (85.1)	5.71 (145.0)	6.69 (169.9)	8.03 (204.0)	7.87 (199.9)
F12-150	13.98 (355.1)	.31 (7.9)	2.63 (66.8)	2.63 (66.8)	4.65 (118.1)	6.77 (172.0)	8.74 (222.0)	7.48 (190.0)	8.35 (212.1)
F12-250	15.55 (395.0)	.31 (7.9)	3.23 (82.0)	2.63 (66.8)	4.65 (118.1)	7.76 (197.1)	9.13 (231.9)	7.87 (199.9)	7.87 (199.9)



# Piston Pumps

## F12 Model Ordering Code

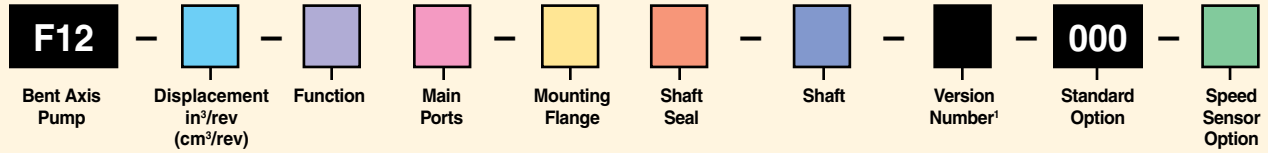

Code	Displacement in³/rev (cm³/rev)
30	1.83 in³/rev (30.0 cc/r)
40	2.44 in³/rev (40.0 cc/r)
60	3.65 in³/rev (59.8 cc/r)
80	4.91 in³/rev (80.4 cc/r)
90	5.68 in³/rev (93.0 cc/r)
110	6.72 in³/rev (110.1 cc/r)
125	7.63 in³/rev (125.0 cc/r)
150	9.15 in³/rev (150.0 cc/r)
250	14.77 in³/rev (242.0 cc/r)

Code	Function
R	Pump, CW Rotation
L	Pump, CCW Rotation

Code	Main Ports	30	40	60	80	90	110	125	150	250
S	SAE Flange	x	x	x	x	x	x	x	—	—
U	SAE, UN Threads	x	x	x	x	x	x	x	—	—
F	SAE 6000 PSI Flange	—	—	—	—	—	—	—	x	x

Code	Mounting Flange	30	40	60	80	90	110	125	150	250
S	SAE 4 bolt	x	x	x	x	x	x	x	x	x
T	SAE 2 bolt	x	x	x	—	—	x	x	—	—
X	SAE D 4 bolt	—	—	—	x	x	—	—	—	—

NOTE: ISO and cartridge mounting also available. See catalog on CD.

x: Available —: Not Available

¹Assigned by factory for special versions

²Order speed sensor kit# 3785190 separately

Code	Shaft Seal	30	40	60	80	90	110	125	150	250
N	NBR*, Low Pressure	x	x	x	x	x	x	x	x	—
V	FPM**, High Pressure, High Temperature	x	x	x	x	x	x	x	x	x

\* NBR - Nitrile rubber  
\*\* FPM - Fluorocarbon rubber

Code	Shaft	30	40	60	80	90	110	125	150	250
S	SAE Spline (std)	x	x	x	x	x	x	x	x	x
U	SAE Spline (opt.)	—	—	—	x	x	—	—	—	—
T	SAE Key (std)	x	x	x	x	x	x	x	x	—
K	Metric Key	—	—	—	—	—	—	—	x	x
F	SAE Spline	—	—	—	—	—	—	—	—	x
D	Spline, DIN 5480	—	—	—	—	—	—	—	—	x

Code	Speed Sensor Option	30	40	60	80	90	110	125	150	250
0	Standard	x	x	x	x	x	x	x	x	x
P	Prepared for Speed Sensor	x	x	x	x	x	x	x	x	x

## F1 Fixed Displacement Bent-Axis Truck Pumps



F1 fixed displacement piston pumps are widely used on truck applications with operating pressure up to 5000 PSI (350 BAR). These lightweight, efficient pumps were designed specifically for truck applications including cargo cranes, hook loaders, forest cranes and concrete mixer trucks.

(For T1 pump version see catalog on CD)

### Pump Performance Data

Model Series	Displacement in <sup>3</sup> /rev (cc/rev)	Maximum Outlet Pressure PSI (BAR)	Rated Drive Speed RPM	Theoretical Max Flow GPM (LPM)	Maximum Input Horsepower HP (KW)
F01-25	1.56 (25.6)	5000 (350)	2600	16 (60.6)	39 (29.1)
F01-41	2.50 (40.9)	5000 (350)	2400	24 (90.8)	57 (42.5)
F01-51	3.12 (51.1)	5000 (350)	2200	28 (106.0)	67 (50.0)
F01-61	3.63 (59.5)	5000 (350)	2200	35 (132.5)	84 (62.6)
F01-81	4.98 (81.6)	5000 (350)	2000	43 (162.8)	102 (76.1)
F01-101	6.28 (102.9)	5000 (350)	1800	49 (185.5)	115 (85.8)

### Markets

### Applications

Forestry	Knuckle Boom Loader, Cranes, Mowers / Cutters
Construction	Off-Highway Trucks, Fan Drives
Mining	Dump Trucks
Material Handling	Truck Mounted Cranes, Lift Trucks
Recycling	Vaccum Truck Systems, Refuse Trucks - ASL, Rear Loaders
Military	Fan Drives

## F1 Fixed Displacement Bent-Axis Truck Pumps

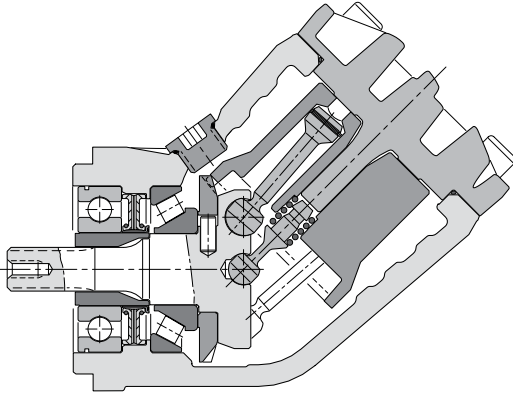

SAE spline shaft shown

### Benefits/Features

- Higher self-priming speeds
- Operating pressures to 5801.51 PSI (400 BAR)
- New frame sizes to meet market requirements
- Higher overall efficiency
- Increased reliability
- Reduced noise level
- Smaller installation dimensions
- Pump rotation easily changed

## F1 Fixed Displacement Bent-Axis Truck Pumps

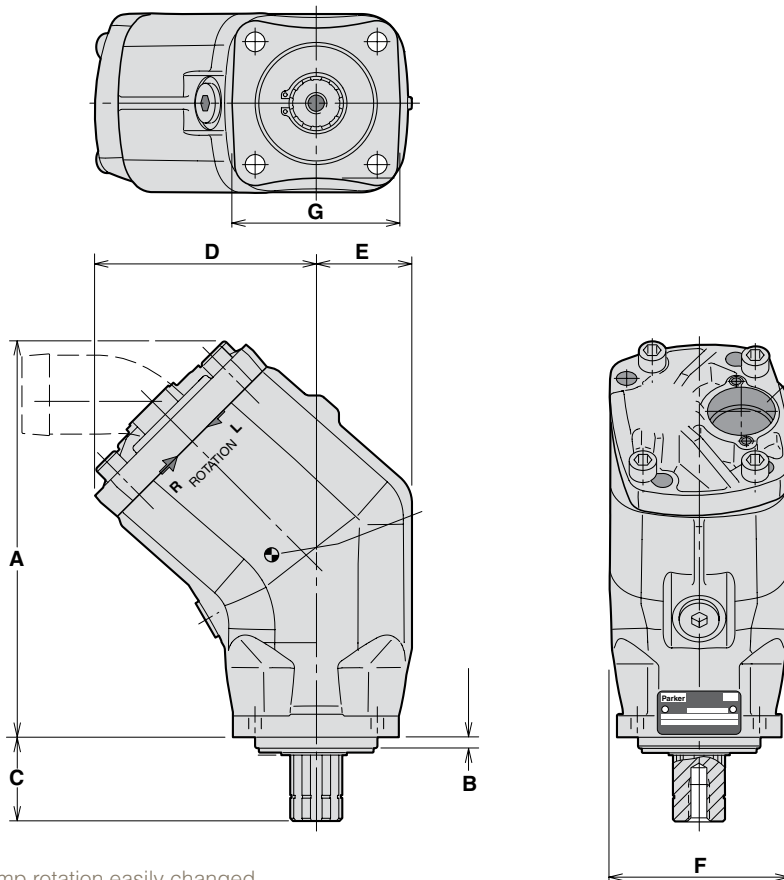

Pump rotation easily changed

### Dimensions, inch (mm)

Series	A	B	C	D	E	F	G
F1-25 F1-41 F1-51 F1-61	8.07 (205)	0.27 (7)	2.17 (55)	5.10 (129.5)	2.22 (56.5)	4.25 (108)	4.29 (109)
F1-81 F1-101	10.20 (259)	0.27 (7)	2.17 (55)	5.67 (144)	2.48 (63)	4.65 (118)	4.33 (110)





# Piston Pumps

## F1 Model Ordering Code

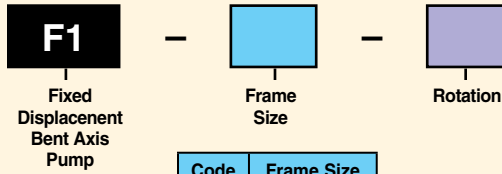

Code	Frame Size
25	1.56 in <sup>3</sup> /rev (25.6 cc/rev)
41	2.50 in <sup>3</sup> /rev (40.9 cc/rev)
51	3.12 in <sup>3</sup> /rev (51.1 cc/rev)
61	3.66 in <sup>3</sup> /rev (59.5 cc/rev)
81	4.98 in <sup>3</sup> /rev (81.6 cc/rev)
101	6.28 in <sup>3</sup> /rev (102.9 cc/rev)

Code	Rotation
L	Left Hand (CCW)
R	Right Hand (CW)

- NOTES:**
1. Pressure port on 25, 41, 51 and 61 sizes is 3/4". Pressure port on 81 and 101 sizes is 1".
  2. Suction fitting must be ordered separately.
  3. Use seven digit number when placing order.

ISO/DIN mounting:

Ordering Code	Ordering No.
F1-25-R	378 1024
F1-25-L	378 1025
F1-41-R	378 1040
F1-41-L	378 1041
F1-51-R	378 1050
F1-51-L	378 1051
F1-61-R	378 1060
F1-61-L	378 1061
F1-81-R	378 1080
F1-81-L	378 1081
F1-101-R	378 1100
F1-101-L	378 1101

See CD for SAE mount versions

### Suction Fittings

A suction fitting consists of a straight, 45°, 90° or 135° suction fitting, 2 clamps, 2 cap screws and an O-ring.

#### Straight Suction Fittings

Ordering no.	A in. (mm)	B in. (mm)	C dia. in. (mm)
378 0635	0 (0)	3.35" (85)	1.5" (38)
378 0636	0.67" (17)	5.35" (136)	2.0" (50)
378 0637	0.98" (25)	5.71" (145)	2.5" (63)
378 0973	0.67" (17)	5.35" (136)	1.77" (45)
378 0974	0.67" (17)	5.35" (136)	1.77" (48)

#### 45° Suction Fittings

Ordering no.	A in. (mm)	B in. (mm)	C dia. in. (mm)
378 1234 <sup>1)</sup>	2.36" (60)	4.09" (104)	1.25" (32)
378 0633 <sup>1)</sup>	2.36" (60)	4.09" (104)	1.5" (38)
378 0364 <sup>2)</sup>	2.64" (67)	4.33" (110)	2" (50)
378 0634	2.95" (75)	4.61" (117)	2.5" (63)
378 1062	2.64" (67)	4.33" (110)	1.57" (40)
378 0975	2.64" (67)	4.33" (110)	1.77" (45)
378 0965	2.64" (67)	4.33" (110)	1.89" (48)

1) Suitable for frame size F1-25.

2) Suitable for pump sizes F1-41,-51,-61,-81 and -110.

#### 90° Suction Fittings

Ordering no.	A in. (mm)	B in. (mm)	C dia. in. (mm)
378 0978	4.96" (126)	3.27" (83)	1.5" (38)
378 0979	5.31" (135)	3.27" (83)	2" (50)
378 0976	5.31" (135)	3.27" (83)	1.77" (45)
378 0977	5.31" (135)	3.27" (83)	1.89" (48)
378 1980	5.79" (147)	4.06" (103)	2.5" (63)

#### 135° Suction Fitting

Ordering no.	A in. (mm)	B in. (mm)	C dia. in. (mm)
378 1867	6.54" (166)	2.87" (73)	2" (50)

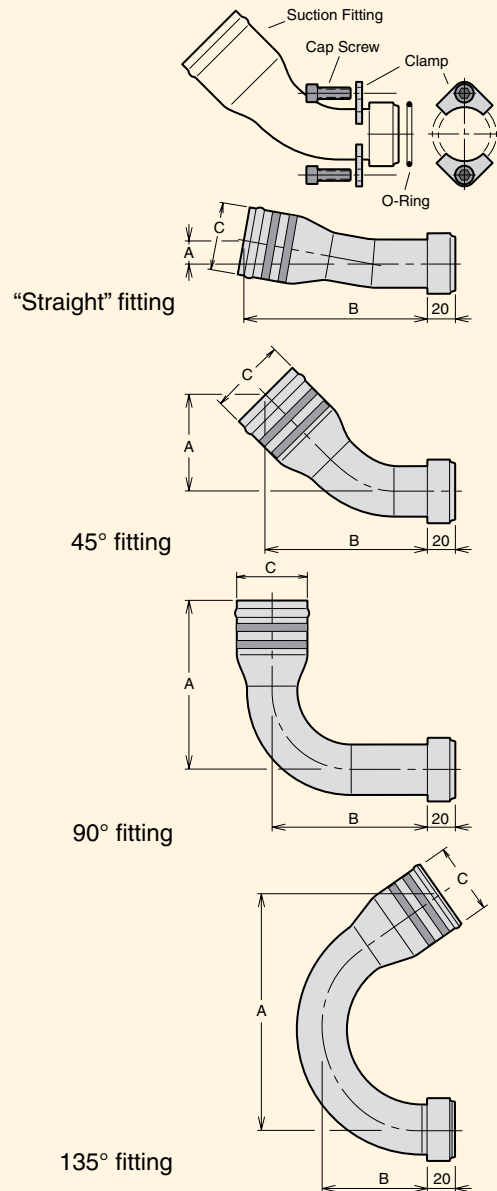

## F2 Twin Flow Bent-Axis Truck Pumps



F2 Fixed Displacement Piston Pumps are widely used on truck applications with operating pressure up to 5000 PSI (350 BAR). These twin flow pumps provide two independent output flows with a single inlet in a compact package. These lightweight, efficient pumps were designed specifically for truck applications including cargo cranes, hook loaders, forest cranes and concrete mixer trucks.

### Pump Performance Data

Model Series	Max. Displacement in <sup>3</sup> /rev (cc/rev)	Outlet Pressure PSI (BAR)	Drive Speed RPM	Flow** @ 1800 RPM		Max. Input Power HP (KW)
				Port A GPM (LPM)	Port B GPM (LPM)	
F2-42/42	2.62/2.50 (43/41)*	5000 (350)	1800	20.4 (77.2)	19.5 (73.8)	118 (88.0)
F2-55/28	3.36/1.71 (55/28)*	5000 (350)	1800	26.1 (98.6)	13.3 (50.3)	118 (88.0)
F2-53/53	3.30/3.17 (54/52)*	5000 (350)	1800	25.5 (96.5)	24.8 (93.9)	147 (109.8)
F2-70/35	4.21/2.20 (69/36)*	5000 (350)	1800	32.7 (123.8)	17.2 (65.1)	147 (109.8)
F2-70/70	4.15/4.15 (68/68)*	4350 (300)	1650	32.3 (122.3)	32.3 (122.3)	150 (111.9)

\*Port A/Port B

\*\* Port A + Port B

### Markets

### Applications

Forestry	Knuckle Boom Loader, Cranes, Mowers / Cutters
Construction	Off-Highway Trucks, Fan Drives
Mining	Dump Trucks
Material Handling	Truck Mounted Cranes, Lift Trucks
Recycling	Vaccum Truck Systems, Refuse Trucks - ASL, Rear Loaders
Military	Fan Drives

## F2 Twin Flow Bent-Axis Truck Pumps

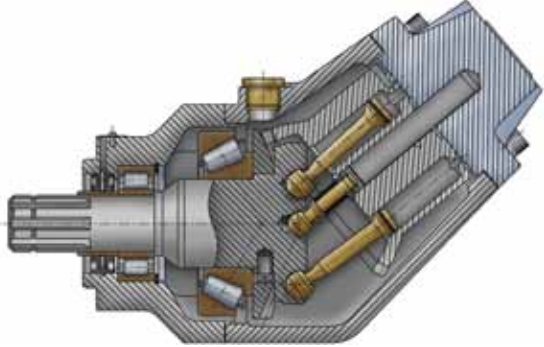

### Benefits/Features

- Two separate outlet flows with a single inlet
- Operating pressures to 6000 PSI (413.7 BAR) intermittent
- Higher overall efficiency
- Increased reliability
- Low noise level
- Compact package that only weighs 42 lbs (19.1 kg).

## F2 Twin Flow Bent-Axis Truck Pumps

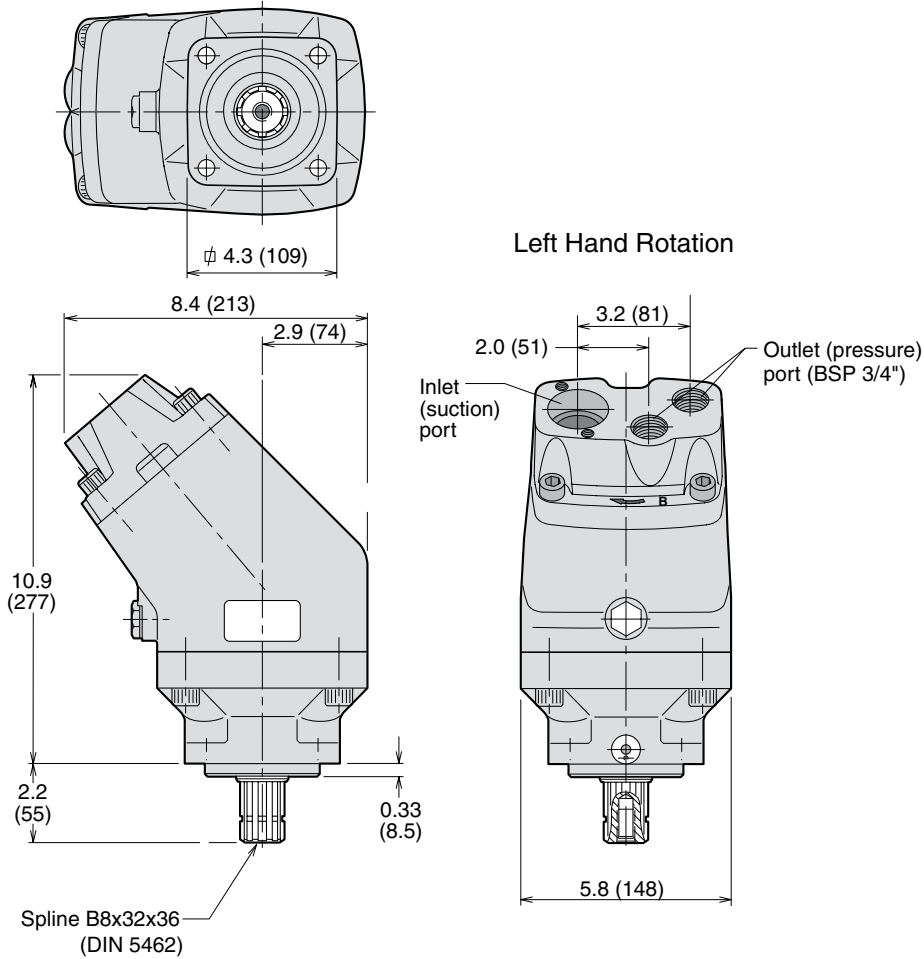



# Piston Pumps

## F2 Model Ordering Code

**F2** — **Frame Size** — **Rotation**

Twin Flow Bent Axis Pump

Frame Size
42/42
55/28
53/53
70/35
70/70

Code	Rotation
L	Left Hand (CCW)
R	Right Hand (CW)

- NOTES:**
1. Pressure port on 25, 41, 51 and 61 sizes is 3/4". Pressure port on 81 and 101 sizes is 1".
  2. Suction fitting must be ordered separately.
  3. Use seven digit number when placing order.

Ordering Code	Ordering No.
F2-42/42-R	378 4042
F2-42/42-L	378 4043
F2-55/28-R	378 4128
F2-55/28-L	378 4129
F2-53/53-R	378 1453
F2-53/53-L	378 1454
F2-70/35-R	378 1470
F2-70/35-L	378 1471
F2-70/70-R	378 4070
F2-70/70-L	378 4071

### Suction Fittings

A suction fitting consists of a straight, 45°, 90° or 135° suction fitting, 2 clamps, 2 cap screws and an O-ring.

#### Straight Suction Fittings

Ordering no.	A in. (mm)	B in. (mm)	C dia. in. (mm)
378 0635	0 (0)	3.35" (85)	1.5" (38)
378 0636	0.67" (17)	5.35" (136)	2.0" (50)
378 0637	0.98" (25)	5.71" (145)	2.5" (63)
378 0973	0.67" (17)	5.35" (136)	1.77" (45)
378 0974	0.67" (17)	5.35" (136)	1.77" (48)

#### 45° Suction Fittings

Ordering no.	A in. (mm)	B in. (mm)	C dia. in. (mm)
378 1234 <sup>1)</sup>	2.36" (60)	4.09" (104)	1.25" (32)
378 0633 <sup>1)</sup>	2.36" (60)	4.09" (104)	1.5" (38)
378 0364 <sup>2)</sup>	2.64" (67)	4.33" (110)	2" (50)
378 0634	2.95" (75)	4.61" (117)	2.5" (63)
378 1062	2.64" (67)	4.33" (110)	1.57" (40)
378 0975	2.64" (67)	4.33" (110)	1.77" (45)
378 0965	2.64" (67)	4.33" (110)	1.89" (48)

1) Suitable for frame size F1-25.

2) Suitable for pump sizes F1-41,-51,-61,-81 and -110.

#### 90° Suction Fittings

Ordering no.	A in. (mm)	B in. (mm)	C dia. in. (mm)
378 0978	4.96" (126)	3.27" (83)	1.5" (38)
378 0979	5.31" (135)	3.27" (83)	2" (50)
378 0976	5.31" (135)	3.27" (83)	1.77"(45)
378 0977	5.31" (135)	3.27" (83)	1.89" (48)
378 1980	5.79" (147)	4.06" (103)	2.5" (63)

#### 135° Suction Fitting

Ordering no.	A in. (mm)	B in. (mm)	C dia. in. (mm)
378 1867	6.54" (166)	2.87" (73)	2" (50)

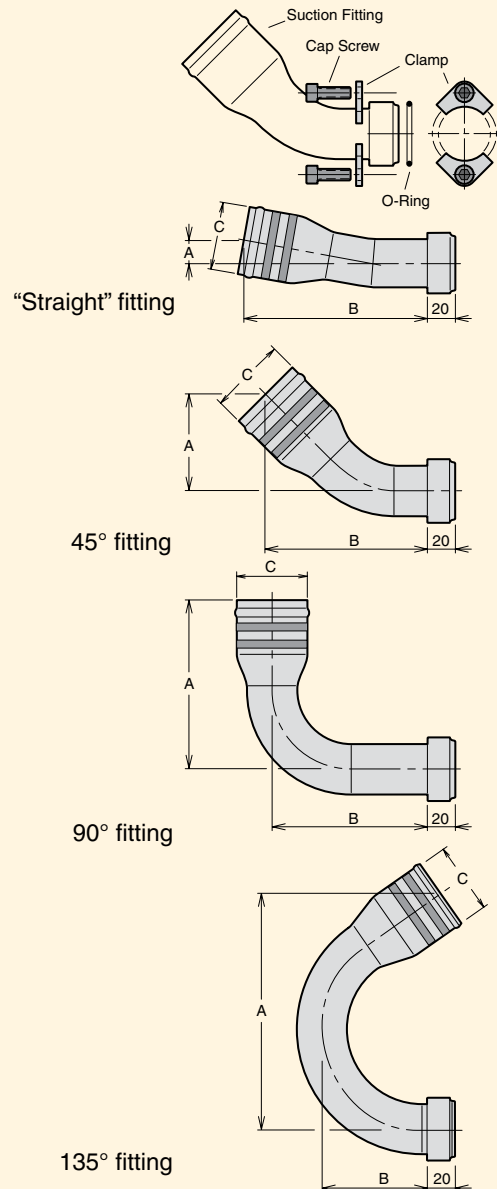





## Gold Cup Hydrostatic Transmissions

*Page*

**(B)** Gold Cup Open & Closed Circuit Pumps & Motors for Hydrostatic Transmissions

**63-74**



ENGINEERING YOUR SUCCESS.



## Gold Cup Open & Closed Circuit Pumps & Motors for Hydrostatic Transmissions



The Gold Cup Hydrostatic Transmission pumps are variable displacement piston pumps of an unparalleled rugged design. Rated to 5000 PSI (350 BAR) continuous pressure and continuous duty, the Gold Cup design has the unique feature of an internal servo/replenish and the ability to utilize system over pressure to directly control the stroking chambers. This affords the fastest and most stable control strategy available. The controls are completely modular in design and can be configured to meet most any system requirements with standard factory options.

All internal wear surfaces are hydrostatically balanced and/or hydraulically linked allowing for a long and serviceable life. The Gold Cup pump also has the ability to run in many open circuit applications and also has digital (Flow/Pressure) capability for the most difficult of control requirements.

The Gold Cup Series has been designed to operate in a wide range of industries needing closed-loop control, high pressure, high power density such as Blast Hole Drill Rigs, Shredding, Cranes, Mining, Hydraulic Test Stands, Pulp and Paper, Military, Marine, and Power Generation.

### Pump Performance Data

Model Series	Displacement in <sup>3</sup> /rev (cc/rev)	Max Continuous Pressure PSI (BAR)	Max Intermittent Pressure** PSI (BAR)	Rated Drive Speed RPM	Flow @ 1800 RPM GPM(LPM)	Input Horsepower @ Max Continuous Pressure & 1800 RPM & 40cSt Petroleum Oil HP (KW)
P6	6.00 (98.3)	5000 (344.8)	6000 (420)	3000	47 (177.9)	153 (114.1)
P7	7.25 (118.8)	5000 (344.8)	6000 (420)	3000	57 (215.8)	183 (136.5)
P8	8.00 (131.1)	5000 (344.8)	5000 (350)	2100	62 (234.7)	145 (108.1)
P11	11.00 (180.3)	5000 (344.8)	6000 (420)	2400	86 (325.5)	275 (205.1)
P14	14.00 (229.5)	5000 (344.8)	6000 (420)	2400	109 (412.6)	348 (259.5)
P24	24.60 (403.2)	5000 (344.8)*	5000 (350)*	2100***	192 (726.8)	626 (466.8)
P30	30.60 (501.5)	5000 (344.8)*	5000 (350)*	1800	238 (900.9)	765 (570.5)

\* Variable speed. Higher servo pressure may be required.

\*\* 10% of operating time, not exceeding 6 successive seconds.

\*\*\* On HF-1 fluids, 1800 RPM max on HF-0 fluids.

### Motor Performance Data

Model Series	Displacement in <sup>3</sup> /rev (cc/rev)	Max Continuous Pressure PSI (BAR)	Max Intermittent Pressure** PSI (BAR)	Max Rated Shaft Speed RPM	Input Flow Required for 1800 RPM GPM (LPM)	Output Torque at Maximum Rated Pressure lb-in (kg-cm)	Output Horsepower @ Max Continuous Pressure and 1800 rpm and 40cSt Petroleum Oil HP (KW)
M6	6.00 (98.3)	5000 (344.8)	6000 (420)	3000	47 (177.9)	4327 (304.2)	123 (91.7)
M7	7.25 (118.8)	5000 (344.8)	6000 (420)	3000	57 (215.8)	5348 (376.0)	153 (114.1)
M8	8.00 (131.1)	5000 (344.8)	5000 (350)	2100	62 (234.7)	4216 (296.4)	120 (89.5)
M11	11.00 (180.3)	5000 (344.8)	6000 (420)	2400	86 (325.5)	8146 (572.8)	232 (173.0)
M14	14.00 (229.5)	5000 (344.8)	6000 (420)	2400	109 (412.6)	10,410 (731.9)	297 (221.5)
M24	24.60 (403.2)	5000 (344.8)*	5000 (350)*	2100***	192 (726.8)	18,320 (1288.0)	523 (390.0)
M30	30.60 (501.5)	5000 (344.8)*	5000 (350)*	1800	238 (900.9)	23,000 (1617.1)	657 (489.89)

\* Variable speed. Higher servo pressure may be required.

\*\* 10% of operating time, not exceeding 6 successive seconds.

\*\*\* On HF-1 fluids, 1800 RPM max on HF-0 fluids.



# Hydrostatic Transmissions (Mobile & Industrial)

## Gold Cup Open & Closed Circuit Pumps & Motors for Hydrostatic Transmissions



### Benefits/Features

- Quick change valve block - easy to service or replace
- Modular controls - easy to service and change
- Versatile controls - can be located on either side of pump or motor for maximum freedom of design
- Dampened low inertia rocker cam - more stable, quieter and faster than other designs
- Exclusive zero-backlash rotary servo design - lifetime accuracy
- Field adjustable compensator override - easily adjusted without removing from machinery
- Precision barrel bearing, a distinctive Parker Denison Hydraulics feature for over 30 years - permits high speeds, high pressure and provides long life
- Ring style replenishing checks fastest operation with no sliding poppets or parts and low pressure drop
- Hot oil shuttle available - fast, reliable operation
- Auxiliary pump can be changed without disassembling the transmission
- Standard SAE keyed or splined drive shafts are available
- High pressure mechanical shaft seals can be changed without disassembling the transmission (excluding the P24 and P30 models). Double lip seals are also available
- One piece stroking vane/cam means no lost motion, zero backlash, better control, and no linkages to wear out
- Stroking vane seals are pressure loaded for longer life
- Standard compensator vent ports allow for a wide variety of controls (See applications manual)
- Rocker cam displacement indicator helps troubleshoot the system
- Modulated servo pressure saves power
- Standard Code 62 SAE split flange connections
- Fastest compensator response: Gives maximum of 10% pressure overshoot at rated conditions (guaranteed times under all conditions faster response times possible depending upon application)
- Variable motors with reverse available for multiple speed ranges or constant power
- Certification Approvals: ATEX, ABS, MIL-P-17869A, and MIL-S-901-C Grade A

### Markets

### Applications

Marine	Deck Cranes, Constant Tension Winches, Steering Gear, Fin Stabilizers,
Oil & Gas	Nitrogen Pumpers, Frac Trucks, Cementers, Coil Tubing
Mining	Drill Rigs, Top Drives, Bucket Reclaimers
Power Gen	Turbine Start
Material Handling	Mixers, Dewatering, Conveyor Drives, Shredders



## Gold Cup Open & Closed Circuit Pumps & Motors for Hydrostatic Transmissions

### Gold Cup Performance Data

**Gold Cup Shaft Input Power - 1800 RPM**

40°C Inlet Oil Temperature – ISO VG 32 Fluid – Max. Displacement

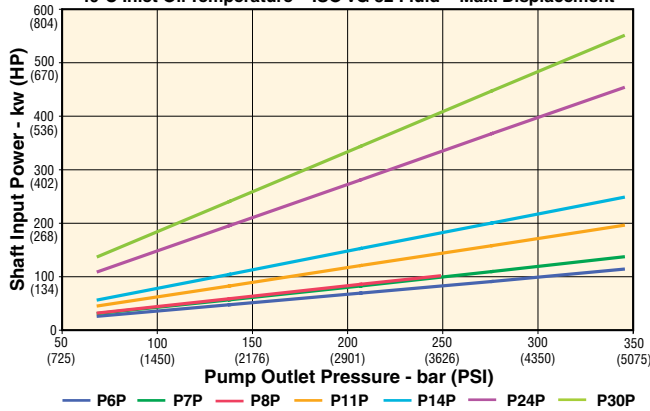

**Gold Cup Overall Efficiency - 1800 RPM**

40°C Inlet Oil Temperature – ISO VG 32 Fluid – Max. Displacement

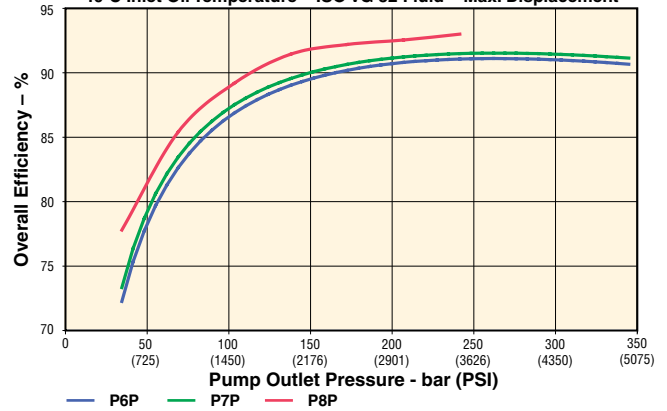

**Gold Cup Pump Outlet Flow - 1800 RPM**

40°C Inlet Oil Temperature – ISO VG 32 Fluid – Max. Displacement

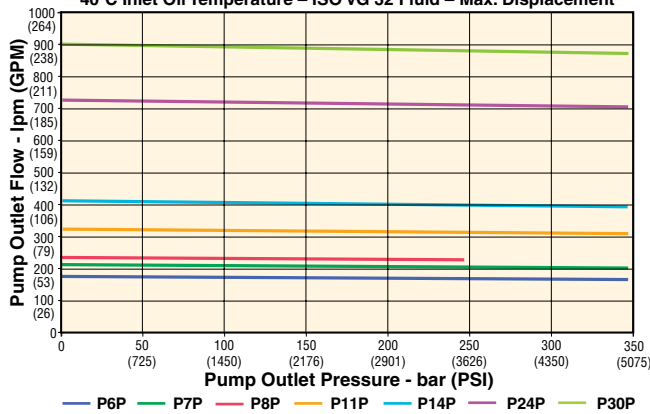

**Gold Cup Overall Efficiency - 1800 RPM**

40°C Inlet Oil Temperature – ISO VG 32 Fluid – Max. Displacement

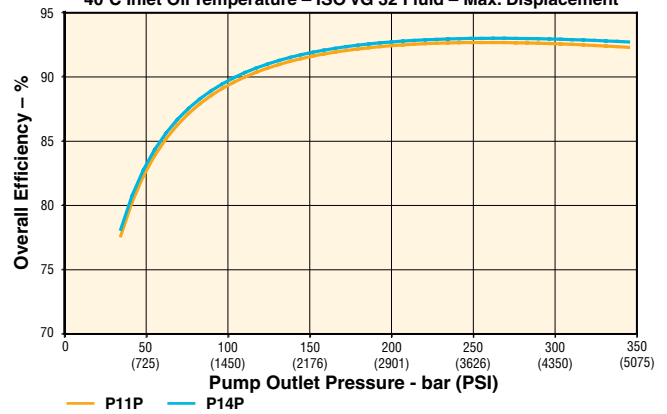

**Gold Cup Overall Efficiency - 1800 RPM**

40°C Inlet Oil Temperature – ISO VG 32 Fluid – Max. Displacement

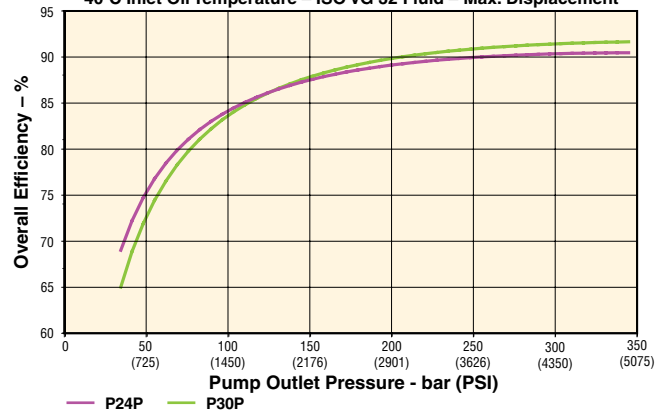



# Hydrostatic Transmissions (Mobile & Industrial)

## Gold Cup Open & Closed Circuit Pumps & Motors for Hydrostatic Transmissions

### Gold Cup Controls

The spring centered rotary servo input, pressure compensator override, and displacement indicator are all standard features on all Gold Cup package pumps.

Spring centering is used in addition to the rotary servo input control to provide a positive return-to-neutral action. It includes an adjustable neutral position to allow fine tuning the neutral position, or offsetting the neutral position. Variable motors have spring offset rotary servo inputs,

cylinder controls and displacement indicators as standard features.

Additional, optional controls are available which increase the utility of the Gold Cup components. These controls include the following:

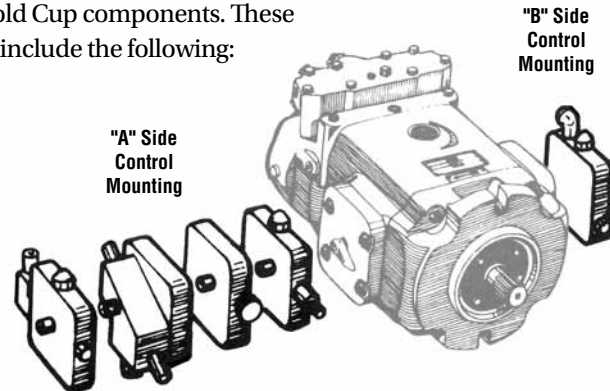

### Primary Controls

Rotary servo	The rotary servo is a mechanically actuated shaft that proportionally positions the pump to the desired flow (all variable units) and direction. A lever is commonly attached and an external mechanical signal of $\pm 19^\circ$ is applied to overcome the spring centering mechanism (20 in lbs spring force) and is directly proportional to the resulting cam angle of the pump.
Hydraulic stroker	The hydraulic stroker is used on both pump and motors. This control positions the rotary servo proportionally to externally controlled pilot pressure.
Electrohydraulic stroker	The electrohydraulic stroker is used on both pumps and motors. It provides an input rotary servo position proportional to input current. It is used primarily with remote electrical controllers. It may be used with programmed controllers as long as the system does not require rapid response.
Electrohydraulic servo	The electrohydraulic servo provides a control for electrohydraulic systems requiring rapid response and precise control. RVDT feedback or Potentiometer feedback are available options.
3-Position cylinder control	The three position cylinder control permits a pump to be offset to an adjustable displacement on either side of center by supplying a pilot signal to the appropriate control port. With no signal the pump returns to an adjustable zero stroke position.
2-Position cylinder control	The two position pump cylinder control permits a pump to be offset to an adjustable displacement on one side of center by supplying a pilot signal to the appropriate control port. With no signal the pump returns to an adjustable zero position. The two position motor cylinder control permits a motor to be stroked to a reduced displacement by supplying a pilot signal to the appropriate control port. With no signal the motor returns to an adjustable maximum stroke position.
Electrohydraulic cylinder control	By mounting an electric directional control valve on the cylinder control, the pump or motor stroke may be controlled by energizing the appropriate solenoid valve, eliminating the need for separate mounting and fluid connections to the control valve.

### Options and Secondary Controls

Adjustable displacement stops	Adjustable stops are available as an option. They provide an adjustment to limit the maximum displacement of the rotary servo input between zero and full displacement on both sides of center.
Manual screw adjustment	A manual screw adjustment is available to provide an easily set pump displacement which will not move during operation. It is used when pump displacement will be adjusted infrequently.
Automatic brake and neutral bypass control	The automatic brake and neutral bypass control is used to actuate a spring set pressure released parking brake and open a small channel between the system ports when the rotary servo input and rocker cam are coincident in the neutral position. If one or the other device is not in the neutral position, the control will not shift into the brake and bypass mode. This control is used on track drives, swing drives, hoist drives and any other system where creeping is intolerable. In some cases this control may be used for the bypass function alone.
Torque limit override	The torque limit override control is used for limiting the input shaft torque. At constant speeds it serves as a horsepower limit override. This control maintains a relationship between displacement and pressure which results in a limitation of the input torque.

## Gold Cup Open & Closed Circuit Pumps & Motors for Hydrostatic Transmissions

**M6  
M7  
M8  
M\*F Shown**

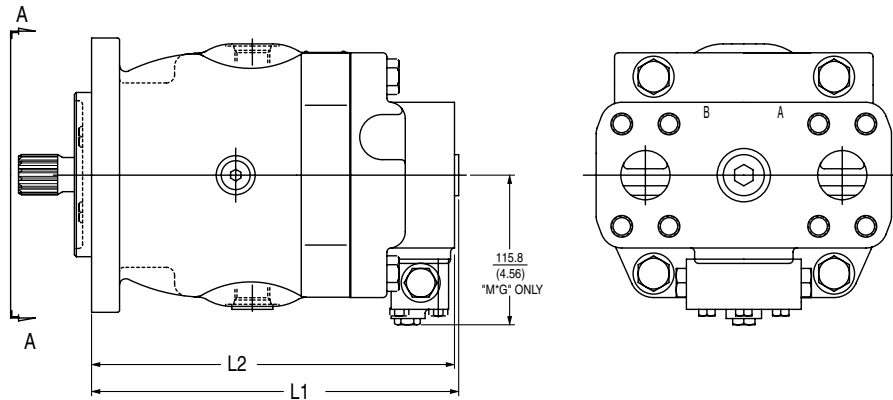

Mounting	L1	L2
SAE127-2 (SAE-C)	11.19 (284.2)	11.06 (280.9)
SAE 152-4 (SAE-D)	11.59 (294.3)	11.46 (291.1)

**P6  
P7  
P8  
P\*P Shown**

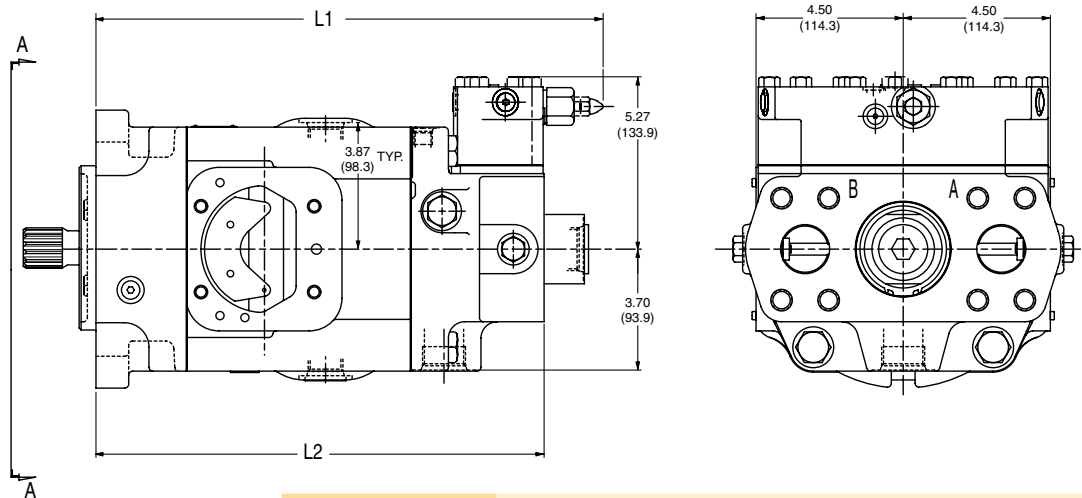

Mounting	L1	L2
SAE127-2 (SAE-C)	15.51 (393.9)	13.70 (348.0)
SAE 152-4 (SAE-D)	16.85 (427.9)	15.04 (382.1)



# Hydrostatic Transmissions (Mobile & Industrial)

## Gold Cup Open & Closed Circuit Pumps & Motors for Hydrostatic Transmissions

### Size 6, 7 and 8 Flange and Shaft Detail

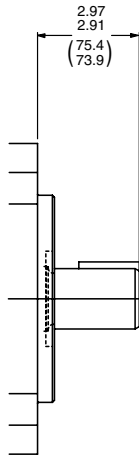

Shaft Code 04  
SAE D Keyed

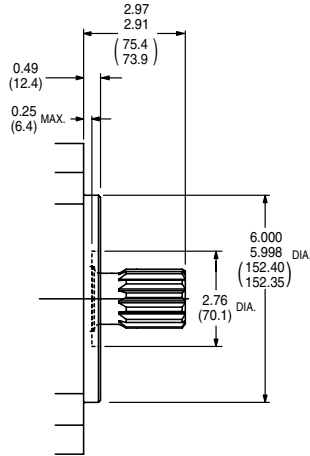

Shaft Code 05  
SAE D Spline

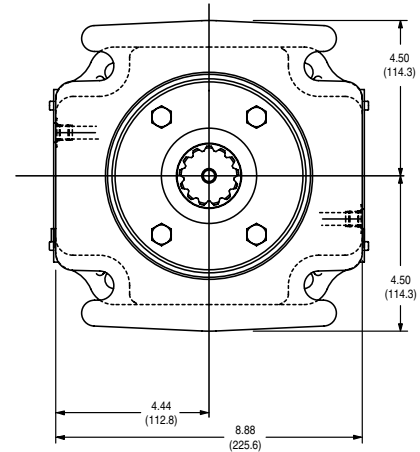

VIEW A-A  
FOR SAE 152-4  
(\"D\" 4-BOLT)

Code	S1
02, 07	2.23 (56.6) 2.15 (54.6)
09, 10	3.36 (85.3) 3.28 (83.3)

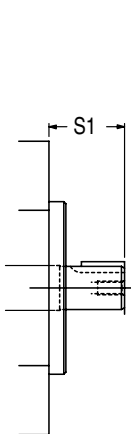

Shaft Codes  
02, 07, 09, 10  
SAE C Keyed

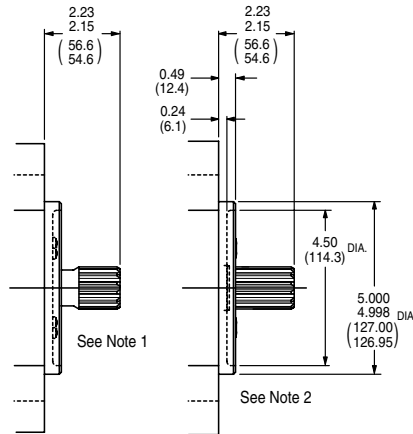

Shaft Codes 03 or 08  
SAE C Spline

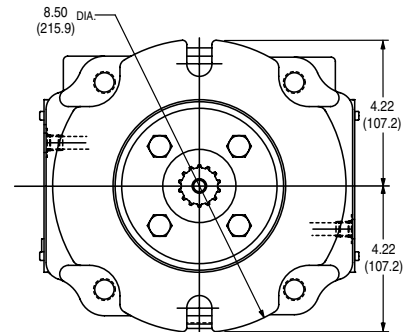

VIEW A-A  
FOR SAE 127-2  
(\"C\" 2-BOLT)

#### NOTES

- 1 Spline length for M\*F, M\*G, M\*H, M\*V, P\*S, P\*X, P\*D, P\*P, P\*V & P\*F.
- 2 Spline length for M\*R, M\*L, M\*M, M\*N, P\*L, P\*R.

## Gold Cup Open & Closed Circuit Pumps & Motors for Hydrostatic Transmissions

**M11**  
**M14**  
**M\*F Shown**

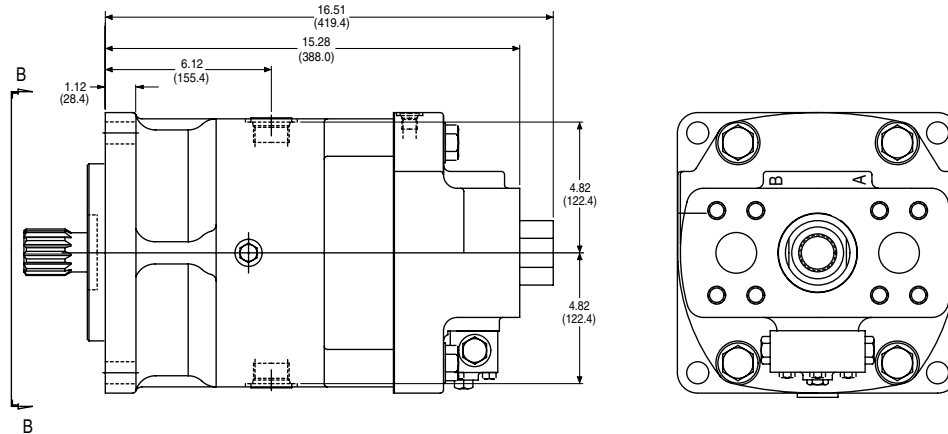

**P11**  
**P14**  
**P\*P Shown**

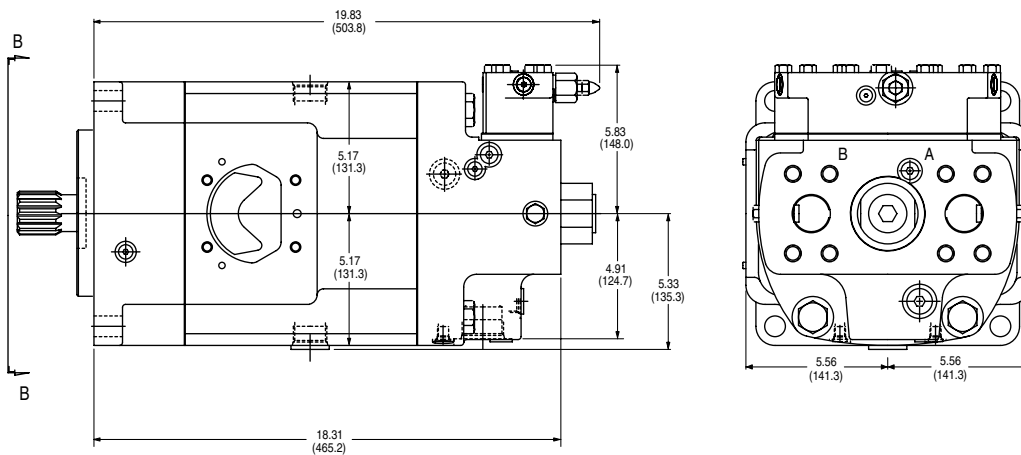

### Size 11 and 14 Flange and Shaft Detail

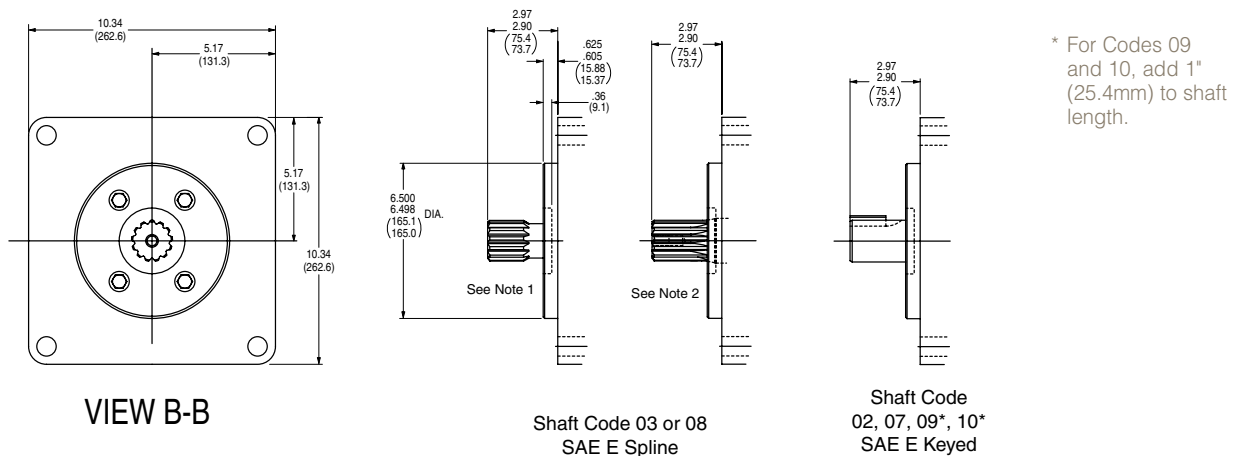

- NOTES
- 1 Spline length for M\*F, M\*G, M\*H, M\*V, P\*S, P\*X, P\*D, P\*P, P\*V & P\*F.
  - 2 Spline length for M\*R, M\*L, M\*M, M\*N, P\*L, P\*R.





# Hydrostatic Transmissions (Mobile & Industrial)

## Gold Cup Open & Closed Circuit Pumps & Motors for Hydrostatic Transmissions

**M24  
M30  
M\*F Shown**

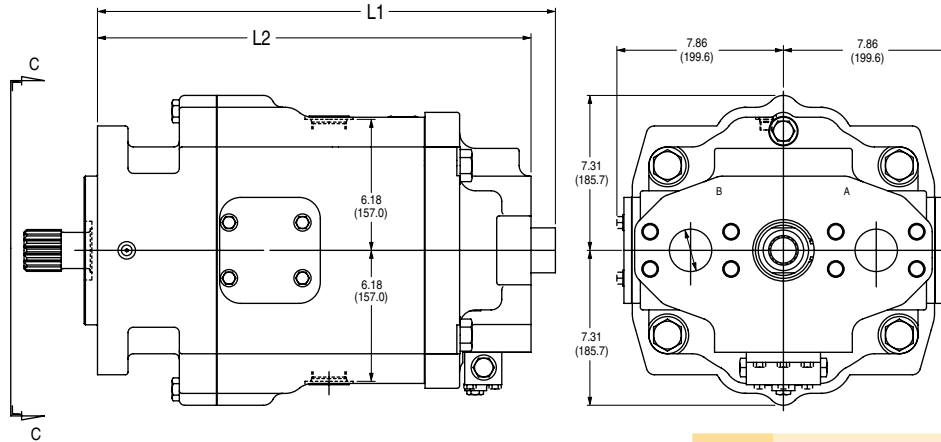

Model	L1	L2
M24F	21.61 (548.8)	20.46 (519.6)
M30F	22.61 (574.2)	21.46 (545.0)

**P24  
P30  
P\*P Shown**

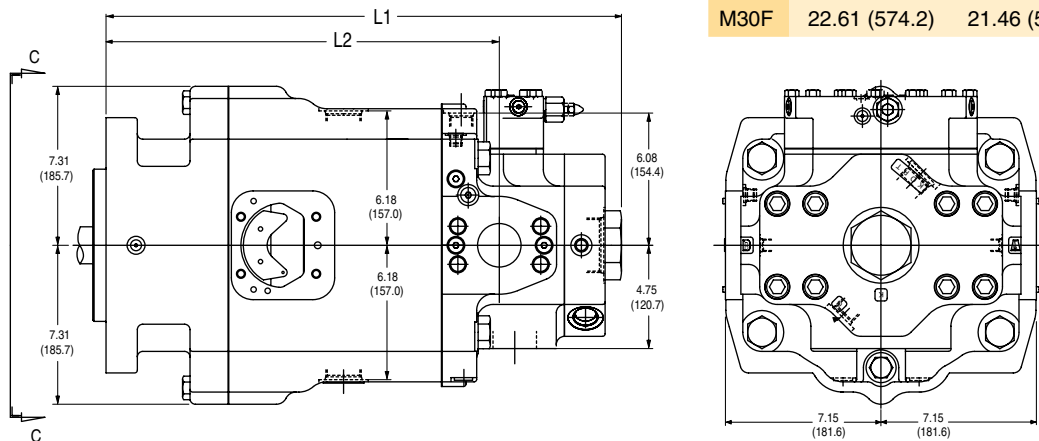

Model	L1	L2
P24P	23.70 (602.1)	18.08 (459.4)
P30P	24.70 (627.5)	19.08 (484.7)

### Size 24 and 30 Flange and Shaft Detail

**NOTES**

- Spline length for M\*F, M\*G, M\*H, M\*V, P\*S, P\*X, P\*D, P\*P, P\*V & P\*F.
- Spline length for M\*R, M\*L, M\*M, M\*N, P\*L, P\*R.

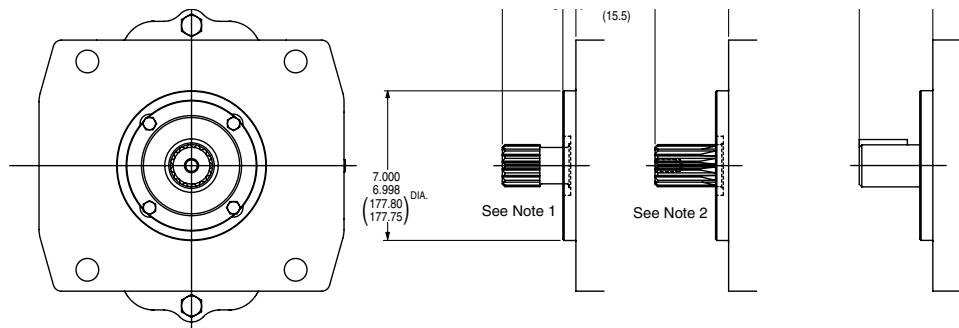

Code	S1
02, 07	3.47 (88.1) 3.41 (86.6)
09, 10	5.35 (135.9) 5.29 (134.4)

VIEW C-C

Shaft Code 03 or 08  
SAE F Spline

Shaft Code 02, 07, 09, 10  
SAE F Keyed

# Hydrostatic Transmissions

## GOLD CUP® Pump Model Ordering Code

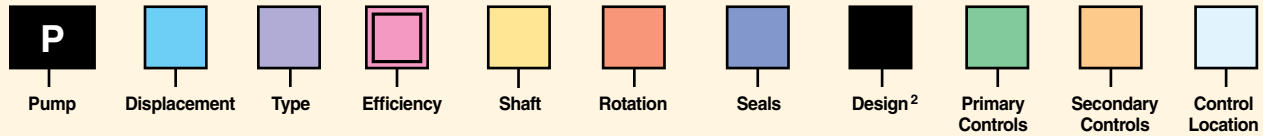

Code	Displacement
6	6.00 in <sup>3</sup> /rev (98 cc/rev)
7	7.25 in <sup>3</sup> /rev (119 cc/rev)
8	8.00 in <sup>3</sup> /rev (131 cc/rev)
11	11.0 in <sup>3</sup> /rev (180 cc/rev)
14	14.0 in <sup>3</sup> /rev (229 cc/rev)
24	24.6 in <sup>3</sup> /rev (403 cc/rev)
30	30.6 in <sup>3</sup> /rev (501 cc/rev)

Code	Type
F	Fixed Displacement, Open/Closed Circuit
M	Fixed Displacement with High Torque Thru-Drive, Open/Closed Circuit
P	Variable Displacement, Closed Circuit
X	Variable Displacement with Medium Torque Thru-Drive, Closed Circuit
S	Variable Displacement with Medium Torque Thru-Drive & Shuttle Package, Closed Circuit
R	Variable Displacement with High Torque Thru-Drive, Closed Circuit
L	Variable Displacement with High Torque Thru-Drive & Shuttle Package, Closed Circuit
V	Variable Displacement, Open Circuit (P6, 7, 8, 11 & 14 only)
D	Variable Displacement, Open & Closed Circuit (P6, 7 & 8 only)

Code	Efficiency
H	High Efficiency (P24 only)
Omit	Standard Efficiency

Code	Shaft
2	Keyed SAE – Mechanical Shaft Seal (Single Lip Seal on P6, 7, 8F/M)
3	Splined SAE – Mechanical Shaft Seal (Single Lip Seal on P6, 7, 8F/M)
4	Keyed SAE-D (Mounting & Shaft) – Mechanical Shaft Seal (P6, 7 & 8 only, Single Lip Seal on Fixed Displacement Pumps)
-5	Splined SAE-D (Mounting & Shaft) – Mechanical Shaft Seal (P6, 7 & 8 only, Single Lip Seal on Fixed Displacement Pumps)
7	Keyed SAE – Double Lip Shaft Seal
8	Splined SAE – Double Lip Shaft Seal
9	Keyed (long) SAE – Double Lip Shaft Seal
10	Keyed (long) SAE – Mechanical Shaft Seal

Code	Rotation
R	Clockwise
L	Counterclockwise

Code	Seals
1	Nitrile (Buna-N)
4	EPR <sup>1,3</sup>
5	Fluorocarbon

Code	Primary Controls
Omit	None (Fixed Displacement only)
10	Screw Adjustment (Spring Offset to Maximum Displacement)
2A	Cylinder Control w/Adjustable Maximum Volume Stops
2H	Cylinder Control – 3-Position (Spring Control with Zero Adjustment)
2M	Cylinder Control – 2-Position Electrohydraulic w/Adjustable Maximum Volume Stop (Spring Offset to Maximum Displacement) <sup>1</sup>
2N	Cylinder Control – 3-Position (Spring Centered) Electrohydraulic <sup>1</sup>
40	Rotary Servo – Spring Centered
4A	Rotary Servo – Spring Centered w/Adjustable Maximum Volume Stops
4B	Rotary Servo – Spring Centered w/Automatic Brake Control
4C	Rotary Servo – Spring centered w/Adjustable Maximum Volume Stops & Automatic Brake Control
5A	Electrohydraulic Stroker w/Adjustable Maximum Volume Stops <sup>1</sup>
5C	Electrohydraulic Stroker w/Adjustable Maximum Volume Stops & Automatic Brake Control <sup>1</sup>
7D	High IQ with 10 GPM Servo Valve & Volume Indicator <sup>1</sup>
7F	High IQ with 10 GPM Servo Valve & 4A (Rotary Servo) Control <sup>1</sup>
7J	High IQ with DF+ Valve & Volume Indicator <sup>1</sup>
7K	High IQ with DF+ Valve & 4A (Rotary Servo) Control <sup>1</sup>
8A	Hydraulic Stroker w/Adjustable Maximum Volume Stops
8C	Hydraulic Stroker w/Adjustable Maximum Volume Stops & Automatic Brake Control
9A	Electrohydraulic Stroker w/Adjustable Maximum Volume Stops <sup>1</sup>
9C	Electrohydraulic Stroker w/Adjustable Maximum Volume Stops & Automatic Brake Control <sup>1</sup>
9D	Electro-hydraulic stroker w/adjustable maximum volume stops

Code	Secondary Controls
Omit	None (Fixed Displacement only)
2	Volume Indicator
4	Torque Limiter & Volume Indicator
6	Cam Position Feedback Potentiometer <sup>1</sup>
7	Cam Position Feedback RVD (AC) <sup>1</sup>
8	Cam Position Feedback RVD (DC) <sup>1</sup>

Code	Control Location
Omit	None (Fixed Displacement only)
A	Primary Control on Port A Side
B	Primary Control on Port B Side

- 1 Not ATEX approved.
- 2 Assigned by manufacturer
- 3 Not available when using "5A" or "5C" primary controls. Pump will be unpainted unless otherwise specified.

 = Omit if not required



# Hydrostatic Transmissions

## GOLD CUP® Pump Model Ordering Code

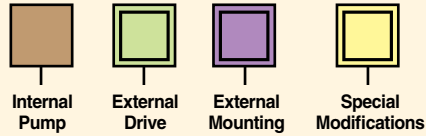
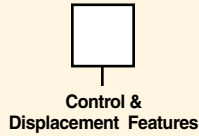

Control	Code	Control & Displacement Features
2M* & 2N*	00	CETOP3, NG6 Valve, 110VAC/60Hz with Hirschmann Connector <sup>1</sup>
	01	CETOP3, NG6 Valve, 12VDC with Hirschmann Connector <sup>1</sup>
	02	CETOP3, NG6 Valve, 240VAC/50Hz with Hirschmann Connector <sup>1</sup>
	03	CETOP3, NG6 Valve, 110VAC/60Hz, Wiring Box <sup>1</sup>
	04	CETOP3, NG6 Valve, 12VDC, Wiring Box <sup>1</sup>
	05	CETOP3 (D03, NG6) Interface, No Valve <sup>1</sup>
	06	CETOP3, NG6 Valve, 24VDC with Hirschmann Connector <sup>1</sup>
	07	CETOP3, NG6 Valve, 110VAC/50Hz with Hirschmann Connector <sup>1</sup>
5**	00	With Deadband <sup>1</sup>
	01	Without Deadband <sup>1</sup>
7**	00	Without Manual Override Shutoff <sup>1</sup>
	01	With Manual Override Shutoff <sup>1</sup> (required for F & K primary options)
8**	00	75-350 PSI (5-24 Bar)
	01	75-435 PSI (5-30 Bar)
	02	100-380 PSI (7-26 Bar)
	03	150-400 PSI (10-28 Bar)
	04	75-250 PSI (5-17 Bar)
9**	00	24VDC
	01	12VDC
All Other	00	None <sup>1</sup>
Pump	Code	Reduced Displacement
P**F & P**M	00	Standard Cam (19°)
	10	P6 with 17° Cam – 5.3 in <sup>3</sup> /rev (87cc/rev)
		P7 with 17° Cam – 6.4 in <sup>3</sup> /rev (105 cc/rev)
		P8 with 17° Cam – 7.1 in <sup>3</sup> /rev (116 cc/rev)
		P11 with 17° Cam – 9.7 in <sup>3</sup> /rev (160 cc/rev)
		P14 with 17° Cam – 12.5 in <sup>3</sup> /rev (205 cc/rev)
20	P24 with 17° Cam – 22.0 in <sup>3</sup> /rev (360 cc/rev)	
	P30 with 17° Cam – 27.2 in <sup>3</sup> /rev (446 cc/rev)	
	P6 with 15° Cam – 4.6 in <sup>3</sup> /rev (76 cc/rev)	
	P7 with 15° Cam – 5.6 in <sup>3</sup> /rev (92 cc/rev)	
30	P8 with 15° Cam – 6.2 in <sup>3</sup> /rev (102 cc/rev)	
	P11 with 15° Cam – 8.5 in <sup>3</sup> /rev (140 cc/rev)	
	P14 with 15° Cam – 10.9 in <sup>3</sup> /rev (179 cc/rev)	
	P6 with 13° Cam – 4.0 in <sup>3</sup> /rev (66 cc/rev)	
P7 with 13° Cam – 4.8 in <sup>3</sup> /rev (79 cc/rev)	P8 with 13° Cam – 5.3 in <sup>3</sup> /rev (88 cc/rev)	

Code	Internal Pump
0	1.07 in <sup>3</sup> /rev (17.5 cc/rev) – P6, 7, 8P/S/X/V/D & P11, 14V only** 2.14 in <sup>3</sup> /rev (35 cc/rev) – P11, 14P/S/X only** 2.81 in <sup>3</sup> /rev (46 cc/rev) – P24, 30P/S/X only (standard)**
1	1.61 in <sup>3</sup> /rev (26.4 cc/rev) – P24, 30P/S/X only (auxiliary external replenishing flow required)
2	1.05 in <sup>3</sup> /rev (17.2 cc/rev) – P24, 30P/S/X only (auxiliary external replenishing flow required)
3	3.56 in <sup>3</sup> /rev (58.3 cc/rev) – P24, 30P/S/X only
4	4.84 in <sup>3</sup> /rev (79.3 cc/rev) – P24, 30P/S/X only
5	5.42 in <sup>3</sup> /rev (88.8 cc/rev) – P24, 30P/S/X only
6	6.10 in <sup>3</sup> /rev (100.0 cc/rev) – P24, 30P/S/X only
X	No Internal Pump (standard on P*R/L/F/M)

\*\* Omit code if no external drive is required.

Code	External Drive
Omit	None <sup>1</sup>
M	Blanking plate – for P6, 7, 8, 11, 14S/X only
A	SAE-A (SAE 82-2) – P6, 7, 8, 11, 14S/X/R/L/M only
B	SAE-B (SAE 101-2) – P6, 7, 8, 11, 14, 24, 30S/X/R/L/M SAE-B (SAE 101-4) – P11, 14, 24, 30R/L/M
C	SAE-C (SAE 127-2) – P6, 7, 8, 11, 14, 24, 30R/L/M & P24, 30S/X SAE-C (SAE 127-4) – P11, 14, 24, 30R/L/M
D	SAE-D (SAE 152-4) – P11, 14, 24, 30R/L/M only
E	SAE-E (SAE 165-4) – P11, 14, 24, 30R/L/M only
F	SAE-F (SAE 177-4) – P24, 30R/L/M only

Code	External Mounting
Omit	No External Drive Required
0	No External Pump Mounted
1	External Pump Mounted (must be separately specified) – Requires Special Modification “-M2” <sup>1</sup>
2	ATEX Externally Mounted Pump

Code	Special Modifications
Omit	None
NP	No Paint <sup>1</sup>
EX	ATEX APPROVED PUMP (May contain additional modifications. Contact tech support.)
M2	Other Special Modification (example: bronze caged barrel bearing for low viscosity fluids, tandem pumps, etc.) <sup>1</sup>

= Omit if not required

# Hydrostatic Transmissions

## GOLD CUP® Motor Model Ordering Code

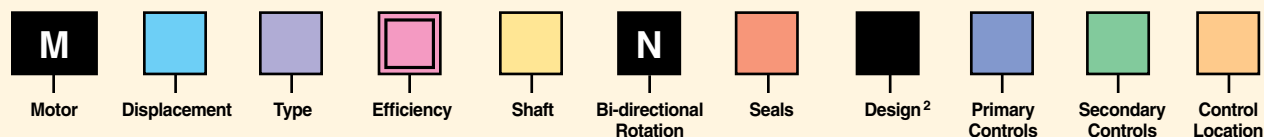

Code	Displacement
6	6.00 in <sup>3</sup> /rev (98cc/rev)
7	7.25 in <sup>3</sup> /rev (119 cc/rev)
8	8.00 in <sup>3</sup> /rev (131 cc/rev)
11	11.0 in <sup>3</sup> /rev (180 cc/rev)
14	14.0 in <sup>3</sup> /rev (229 cc/rev)
24	24.6 in <sup>3</sup> /rev (403 cc/rev)
30	30.6 in <sup>3</sup> /rev (501 cc/rev)

Code	Type
F	Fixed Displacement
G	Fixed Displacement with Shuttle Package
M	Fixed Displacement with Thru-Drive
N	Fixed Displacement with Thru-Drive & Shuttle Package
V	Variable Displacement
H	Variable Displacement with Shuttle Package
R	Variable Displacement with Thru-Drive
L	Variable Displacement with Thru-Drive & Shuttle Package

Code	Efficiency
H	High Efficiency (M24 only)
Omit	Standard Efficiency

Code	Shaft
2	Keyed SAE – Mechanical Shaft Seal (Single Lip Seal on M6, 7, 8F/G/M/N)
3	Splined SAE – Mechanical Shaft Seal (Single Lip Seal on M6, 7, 8F/G/M/N)
4	Keyed SAE-D (Mounting & Shaft) – Mechanical Shaft Seal (M6, 7 & 8 only, Single Lip Seal on Fixed Displacement Motors)
5	Splined SAE-D (Mounting & Shaft) – Mechanical Shaft Seal (P6, 7 & 8 only, Single Lip Seal on Fixed Displacement Motors)
7	Keyed SAE – Double Lip Shaft Seal
8	Splined SAE – Double Lip Shaft Seal
9	Keyed (long) SAE – Double Lip Shaft Seal
10	Keyed (long) SAE – Mechanical Shaft Seal

Code	Seals
1	Nitrile (Buna-N)
4	EPR <sup>3</sup>
5	Fluorocarbon

Code	Primary Controls
Omit	None (Fixed Displacement only)
2A	Cylinder Control w/Adjustable Maximum Volume Stops
2M	Cylinder Control – 2-Position Electrohydraulic w/Adjustable Maximum Volume Stop (Spring Offset to Maximum Displacement) <sup>1</sup>
5A	Electrohydraulic Stroker w/ Adjustable Maximum Volume Stops <sup>1</sup>
8A	Hydraulic Stroker w/Adjustable Maximum Volume Stops
9A	Electrohydraulic Stroker w/ Adjustable Maximum Volume Stops <sup>1</sup>

Code	Secondary Controls
Omit	None (Fixed Displacement only)
0	Volume Indicator
3	Reverse Compensator (spring offset to maximum displacement) + Volume Indicator
5	Reverse Compensator (spring offset to minimum displacement) + Volume Indicator
6	Cam Position Feedback Potentiometer <sup>1</sup>
7	Cam Position Feedback RVDT (AC) <sup>1</sup>
8	Cam Position Feedback RVDT (DC) <sup>1</sup>
U	Reverse Compensator (3) + Cam Position Feedback Potentiometer (6) <sup>1</sup>
W	Reverse Compensator (3) + Cam Position Feedback RVDT (8) <sup>1</sup>
X	Reverse Compensator (5) + Cam Position Feedback Potentiometer (6) <sup>1</sup>
Z	Reverse Compensator (5) + Cam Position Feedback RVDT (8) <sup>1</sup>

Code	Control Location
Omit	None (Fixed Displacement only)
A	Primary Control on Port A Side
B	Primary Control on Port B Side

1 Not ATEX approved.  
 2 Assigned by manufacturer.  
 3 Not available when using "5A" primary control. Motor will be unpainted unless otherwise specified.

= Omit if not required



# Hydrostatic Transmissions

## GOLD CUP® Motor Model Ordering Code



Control & Displacement Features



Shuttle Valve Features



External Drive



External Mounting



Special Modifications

Control	Code	Control & Displacement Features
2M	0	CETOP3, NG6 Valve, 110AC/60Hz with Hirschmann Connector <sup>1</sup>
	1	CETOP3, NG6 Valve, 12VDC with Hirschmann Connector <sup>1</sup>
	2	CETOP3, NG6 Valve, 240VAC/50Hz with Hirschmann Connector <sup>1</sup>
	3	CETOP3, NG6 Valve, 110VAC/60Hz, Wiring Box <sup>1</sup>
	4	CETOP3, NG6 Valve, 12VDC, Wiring Box <sup>1</sup>
	5	CETOP3 (D03, NG6) Interface, No Valve <sup>1</sup>
	6	CETOP3, NG6 Valve, 24VDC with Hirschmann Connector <sup>1</sup>
	7	CETOP3, NG6 Valve, 110VAC/50Hz with Hirschmann Connector <sup>1</sup>
5A	0	With Deadband <sup>1</sup>
	1	Without Deadband <sup>1</sup>
8A	0	75-250 PSI (5-17 Bar)
	1	250-450 PSI (17-31 Bar)
9A	0	24VDC <sup>1</sup>
	1	12VDC <sup>1</sup>
All Other	0	None
Motor	Code	Reduced Displacement
M*F M*G M*M M*N	0	Standard Cam (19°)
	1	M6 with 17° Cam – 5.3 in <sup>3</sup> /rev (87cc/rev) M7 with 17° Cam – 6.4 in <sup>3</sup> /rev (105 cc/rev) M8 with 17° Cam – 7.1 in <sup>3</sup> /rev (116 cc/rev) M11 with 17° Cam – 9.7 in <sup>3</sup> /rev (160 cc/rev) M14 with 17° Cam – 12.5 in <sup>3</sup> /rev (205 cc/rev) M24 with 17° Cam – 22.0 in <sup>3</sup> /rev (360 cc/rev) M30 with 17° Cam – 27.2 in <sup>3</sup> /rev (446 cc/rev)
	2	M6 with 15° Cam – 4.6 in <sup>3</sup> /rev (76 cc/rev) M7 with 15° Cam – 5.6 in <sup>3</sup> /rev (92 cc/rev) M8 with 15° Cam – 6.2 in <sup>3</sup> /rev (102 cc/rev) M11 with 15° Cam – 8.5 in <sup>3</sup> /rev (140 cc/rev) M14 with 15° Cam – 10.9 in <sup>3</sup> /rev (179 cc/rev)
	3	M6 with 13° Cam – 4.0 in <sup>3</sup> /rev (66 cc/rev) M7 with 13° Cam – 4.8 in <sup>3</sup> /rev (79 cc/rev) M8 with 13° Cam – 5.3 in <sup>3</sup> /rev (88 cc/rev)

Code	Shuttle Valve Features
Omit	M*F/M/V/R Motors only
0	Without Orifices
2	With Orifices

Code	External Drive
Omit	None (M*F/G/V/H units only)
A	SAE-A (SAE 82-2) – M6, 7, 8, 11, 14M/N/R/L only
B	SAE-B (SAE 101-2) – M6, 7, 8M/N/R/L SAE-B (SAE 101-2 & 101-4) – M11, 14, 24, 30M/N/R/L
C	SAE-C (SAE 127-2) – M6, 7, 8M/N/R/L SAE-C (SAE 127-2 & 127-4) – M11, 14, 24, 30M/N/R/L
D	SAE-D (SAE 152-4) – M11, 14, 24, 30M/N/R/L only
E	SAE-E (SAE 165-4) – M11, 14, 24, 30M/N/R/L only
F	SAE-F (SAE 177-4) – M24, 30M/N/R/L only
M	Blanking Plate-less Coupling

Code	External Mounting
0	No External Motor Mounted
1	External Motor Mounted (must be separately specified) – Requires Special Modification “-M2”
2	ATEX Externally Mounted Motor

Code	Special Modifications
Omit	None
NP	No Paint
M2	Other Special Modification (example: bronze caged barrel bearing for low viscosity fluids, tandem motors, etc.)
EX	ATEX APPROVED (May contain additional modifications. Contact tech support.)

= Omit if not required





# Vane Pumps

*Page*

**(M)** = Mobile **(I)** = Industrial **(B)** = Mobile & Industrial

<b>(B)</b>	<b>SDV 10/20 Medium Pressure Single Vane Pumps</b>	<b>77-80</b>
<b>(B)</b>	<b>SDV2010 Medium Pressure Double Vane Pumps</b>	<b>81-84</b>
<b>(B)</b>	<b>T7A Series High Performance Small Displacement Single Vane Pumps</b>	<b>85-86</b>
<b>(B)</b>	<b>T6 Series Single, Double &amp; Triple High Performance Vane Pumps</b>	<b>87-90</b>
<b>(B)</b>	<b>T7 Series Single, Double &amp; Triple High Performance Vane Pumps</b>	<b>91-93</b>
<b>(B)</b>	<b>T67 Series High Performance Vane Pumps</b>	<b>94-96</b>
<b>(B)</b>	<b>T6H/T7H Hybrid Technology Variable Piston Fixed Vane Pumps</b>	<b>97-100</b>



ENGINEERING YOUR SUCCESS.

## SDV 10/20 Medium Pressure Single Vane Pumps



The SDV Series are a fixed displacement vane pump ideal for low to mid-pressure applications. Their compact design and low noise features make them well suited for filter carts, test stands and remote pilot pumps.

### Pump Performance Data

Single Pump Model Series**	Displacement in <sup>3</sup> /rev (cc/rev)	Max. Outlet Pressure PSI (BAR)	Rated Drive Speed RPM	Flow @ 1800 rpm and 0 PSI GPM (LPM)	Input Horsepower @ 1800 rpm and 2500 PSI HP (KW)
SDV10-1*1	0.20 (3.3)	2500 (175)	1800	1.6 (6.1)	2.89 (2.2)
SDV10-1*2	0.40 (6.6)	2500 (175)	1800	3.1 (11.7)	4.83 (3.6)
SDV10-1*3	0.60 (9.8)	2500 (175)	1800	4.7 (17.8)	7.65 (5.7)
SDV10-1*4	0.80 (13.1)	2500 (175)	1800	6.2 (23.5)	9.87 (7.4)
SDV10-1*5	1.00 (16.4)	2500 (175)	1800	7.8 (29.5)	12.77 (9.5)
SDV10-1*6	1.19 (19.5)	2200 (150)	1800	9.3 (35.2)	15.11 (11.3)
SDV10-1*7	1.39 (22.8)	2000 (140)	1800	10.8 (40.9)	18.01 (13.4)

Single Pump Model Series**	Displacement in <sup>3</sup> /rev (cc/rev)	Max. Outlet Pressure PSI (BAR)	Rated Drive Speed RPM	Flow @ 0 PSI* GPM (LPM)	Input Horsepower @ 2500 PSI* HP (KW)
SDV20-1*6	1.19 (19.5)	2500 (175)	1800	9.27 (35.1)	14.5 (10.8)
SDV20-1*7	1.39 (22.8)	2500 (175)	1800	10.84 (41.0)	16.4 (12.2)
SDV20-1*8	1.62 (26.5)	2500 (175)	1800	12.60 (47.7)	19.5 (14.5)
SDV20-1*9	1.81 (29.7)	2500 (175)	1800	14.12 (53.5)	22.1 (16.5)
SDV20-1*11	2.22 (36.4)	2500 (175)	1800	17.31 (65.5)	28.6 (21.3)
SDV20-1*12	2.38 (39.0)	2200 (150)	1800	18.55 (70.2)	30.4 (22.7)
SDV20-1*13	2.59 (42.4)	2000 (140)	1800	20.16 (76.3)	33.2 (24.8)

\* @ 1800 RPM.

\*\* Based on combinations of SDV20 pumps.





# Vane Pumps (Mobile & Industrial)

## SDV 10/20 Medium Pressure Single Vane Pumps

### Benefits/Features

- Two compact frame sizes available
- Low noise
- 100% tested
- Easy to convert or repair

SDV10

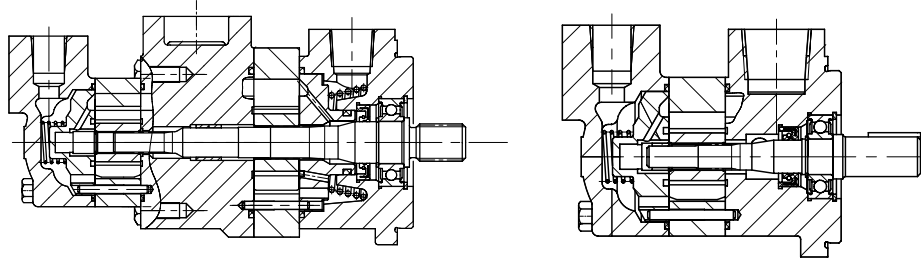

SDV20

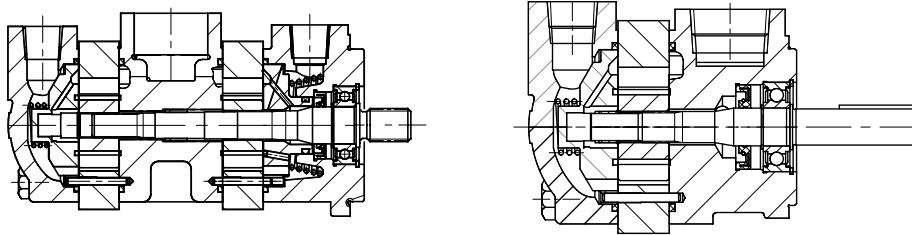

### Pump Performance Data

SDV10 Size	Output Flow (l/min)		Output Flow (GPM)		Input Power (kW)		Input Power (HP)	
	0 BAR	150 BAR	0 PSI	2000 PSI	7 BAR	150 BAR	80 PSI	2500 PSI
1	6.1	3.9	1.6	1.0	0.1	1.44	0.14	1.93
2	11.9	9.9	3.1	2.6	0.21	3.6	0.28	4.83
3	17.8	15.6	4.7	4.1	0.31	5.7	0.41	7.65
4	23.6	20.2	6.2	5.3	0.41	7.4	0.55	9.87
5	29.5	98.8	7.8	26.1	0.51	9.52	0.69	12.77
6	35.2	31.0	9.3	8.2	0.61	11.3	0.82	15.11
7	41.0	36.8	10.8	9.7	0.71	13.43	0.96	18.01

SDV20 Size	Output Flow (l/min)		Output Flow (GPM)		Input Power (kW)		Input Power (HP)	
	0 BAR	150 BAR	0 PSI	2000 PSI	7 BAR	150 BAR	80 PSI	2500 PSI
6	35.1	31.5	9.27	8.32	0.5	10.8	0.7	14.5
7	41.0	35.7	10.84	9.42	0.7	12.2	0.9	16.4
8	47.7	42.3	12.60	11.18	0.7	14.5	1.0	19.5
9	53.5	48.1	14.12	12.70	0.8	16.5	1.1	22.1
11	65.5	62.1	17.31	16.41	1.0	21.3	1.4	28.6
12	70.2	66.0	18.55	17.44	1.1	22.7	1.5	30.4
13	76.3	72.1	20.16	19.05	1.2	24.8	1.2	33.2

## SDV 10/20 Medium Pressure Single Vane Pumps

SDV10

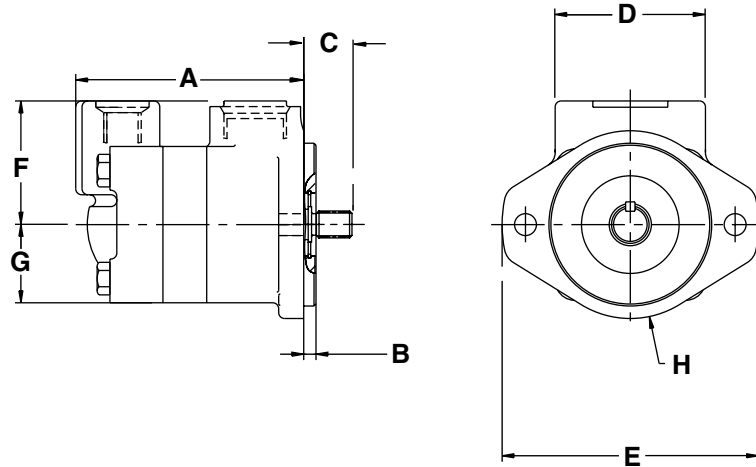

SDV20

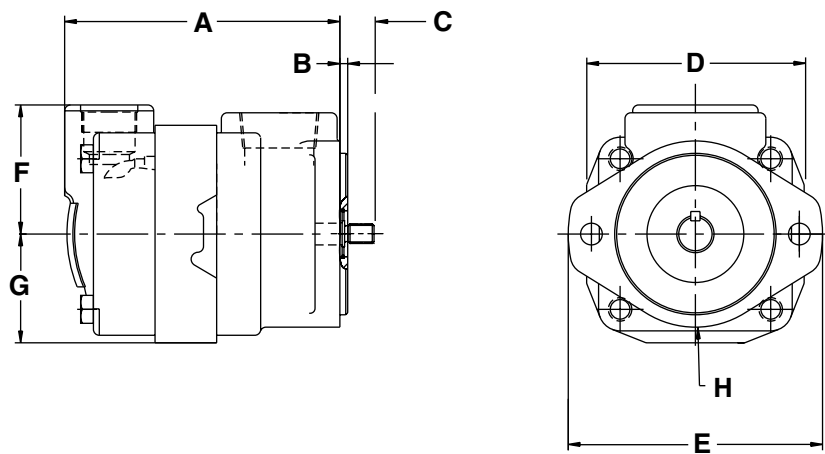

### Dimensions, inch (mm)

Ring Size	A*	B	C Max	D	ØE	F	G	ØH
SDV10	4.55 (115.6) to 5.00 (127.0)	0.250 (6.35)	1.75 (44.4)	3.00 (76.2)	5.12 (130.00)	2.47 (62.7)	1.50 (38.1)	3.75 (95.2)
SDV20	4.93 (125.2) to 5.52 (140.2)	0.173 (4.4)	2.66 (67.6)	4.38 (111.2)	5.12 (130.00)	2.60 (66.0)	2.19 (55.6)	3.75 (95.2)

\* Depending on ring size



# Vane Pumps

## SDV 10/20 Model Ordering Code

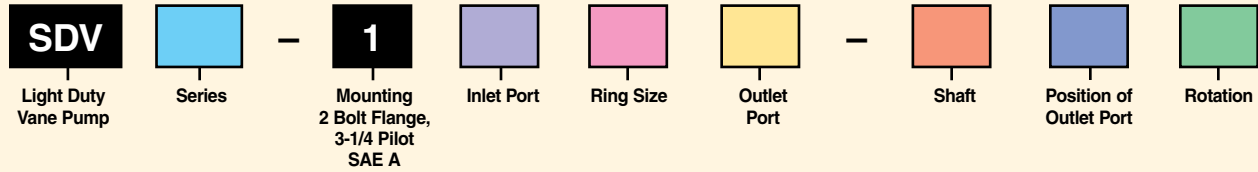

Code	Series
10	Size 10, 1-7 GPM (3.8-26.5 LPM)
20	Size 20, 6-13 GPM (22.7-49.2 LPM)

Code	Inlet Port Connection	
	SDV10	SDV20
P	1" NPTF Thread	1 1/4" NPTF Thread
S	1 5/16"-12 UNF-2B Thread	1 5/8"-12 UNF-2B Thread
B	G1" (BSPP)	G1 1/2" (BSPP)

Code	Ring Size ***
1*	1 GPM (3.8 LPM)
2*	2 GPM (7.6 LPM)
3*	3 GPM (11.4 LPM)
4*	4 GPM (15.1 LPM)
5*	5 GPM (18.9 LPM)
6	6 GPM (22.7 LPM)
7	7 GPM (26.5 LPM)
8**	8 GPM (30.3 LPM)
9**	9 GPM (34.1 LPM)
10**	10 GPM (37.9 LPM)
11**	11 GPM (41.6 LPM)
12**	12 GPM (45.4 LPM)
13**	13 GPM (49.2 LPM)

\* SDV10 only  
 \*\* SDV20 only  
 \*\*\* Delivery at 1200 RPM and 100 PSI

Code	Outlet Port Connection	
	SDV10	SDV20
P	1/2" NPTF Thread	3/4" NPTF Thread
S	3/4"-16 UNF-2B Thread	1 1/16"-12 UNF-2B Thread
B	G1/2" (BSPP)	G3/4" (BSPP)

Code	Shaft
1	Straight Keyed
11	Splined
38	11 Teeth - 3/4" OD
62*	Splined

\* SDV20 only

Code	Position of Outlet Port*
A	Opposite Inlet Port
B	90° CCW from Inlet
C	In Line with Inlet
D	90° CW from Inlet

\* Viewed from cover end of pump

Code	Rotation*
Omit	CW
L	CCW

\* As viewed from shaft end.

## SDV2010 Medium Pressure Double Vane Pumps



The SDV Series are a fixed displacement vane pump, ideal for low to mid pressure applications. The double pump provides the flexibility of two different displacements within one housing. The

compact design and low noise features make them well suited for filter carts, test stands, remote pilot pumps, and for hi/lo circuits.

### Pump Performance Data

Series SDV2010	-7	-8	-9	-11	-12	-13
Displacement* in <sup>3</sup> /rev (cc/rev)	1.6 - 2.8 (26.1 - 45.6)	1.8 - 3.0 (29.8 - 49.3)	2.0 - 3.2 (33.0 - 52.5)	2.4 - 3.6 (39.7 - 59.2)	2.6 - 3.8 (42.3 - 61.8)	2.8 - 4.0 (45.7 - 65.2)
Max. continuous pressure PSI (BAR)	2500 (175)	2500 (175)	2500 (175)	2500 (175)	2200 (150)	2200 (150)
Max. speed RPM	1800	1800	1800	1800	1800	1800

\* Range calculated by adding displacement for SDV20 to range of displacements for SDV10.

Series SDV2020	-7	-8	-9	-11	-12	-13
Displacement* in <sup>3</sup> /rev (cc/rev)	2.6 - 3.2 (42.3 - 52.5)	2.8 - 3.4 (46.0 - 56.2)	3.0 - 3.6 (49.2 - 59.4)	3.4 - 4.4 (55.9 - 72.8)	3.6 - 4.6 (58.5 - 75.4)	3.8 - 4.8 (61.9 - 78.8)
Max. continuous pressure PSI (BAR)	2500 (175)	2500 (175)	2500 (175)	2500 (175)	2200 (150)	2200 (150)
Max. speed RPM	1800	1800	1800	1800	1800	1800

\* Range calculated by adding displacement for SDV20 (shaft end) to range of SDV20 (cover end).

Double Pump Model Series**	Displacement Range* in <sup>3</sup> /rev (cc/rev)	Max. Outlet Pressure PSI (BAR)	Rated Drive Speed RPM	Flow @ 0 PSI @ 1800 RPM GPM (LPM)	Input Horsepower @2500 PSI @1800 RPM HP (KW)
SDV2010-1F7	10.28 - 17.95 (26.1 - 45.6)	2500 (175)	1800	12.4 - 21.6 (46.9 - 81.8)	19.3 - 34.4 (14.4 - 25.7)
SDV2010-1F8	11.73 - 19.41 (29.8 - 49.3)	2500 (175)	1800	14.2 - 23.4 (53.8 - 88.6)	22.4 - 37.5 (16.7 - 28.0)
SDV2010-1F9	12.99 - 20.67 (33.0 - 52.5)	2500 (175)	1800	15.7 - 24.9 (59.4 - 94.3)	25.0 - 40.1 (18.6 - 29.9)
SDV2010-1F11	15.63 - 23.31 (39.7 - 59.2)	2500 (175)	1800	18.9 - 28.1 (71.5 - 106.4)	31.5 - 46.6 (23.5 - 34.7)
SDV2010-1F12	16.65 - 24.33 (42.3 - 61.8)	2200 (150)	1800	20.2 - 29.4 (177.5 - 309.6)	33.3 - 48.4 (24.8 - 36.1)
SDV2010-1F13	17.99 - 25.67 (45.7 - 65.2)	2200 (150)	1800	21.8 - 31.0 (82.5 - 177.3)	36.1 - 51.2 (26.9 - 38.2)

\*Based on combinations with SDV10 sizes.

\*\*Complete model code required, see catalog on CD.

Double Pump Model Series**	Displacement Range* in <sup>3</sup> /rev (cc/rev)	Max. Outlet Pressure PSI (BAR)	Rated Drive Speed RPM	Flow @ 0 PSI @ 1800 RPM GPM (LPM)	Input Horsepower @2500 PSI @1800 RPM HP (KW)
SDV2020-1F7	16.65 - 25.67 (42.3 - 65.2)	2500 (175)	1800	20.1 - 25.0 (76.1 - 94.6)	30.9 - 38.5 (23.0 - 28.7)
SDV2020-1F8	18.11 - 27.13 (46.0 - 68.9)	2500 (175)	1800	21.9 - 26.7 (82.9 - 101.1)	34.0 - 41.6 (25.4 - 31.0)
SDV2020-1F9	19.37 - 28.39 (49.2 - 72.1)	2500 (175)	1800	23.4 - 28.2 (88.6 - 106.7)	36.6 - 44.2 (27.3 - 33.0)
SDV2020-1F11	22.01 - 31.02 (55.9 - 78.8)	2500 (175)	1800	26.6 - 37.5 (100.7 - 142.0)	43.1 - 61.8 (32.1 - 46.1)
SDV2020-1F12	23.03 - 32.05 (58.5 - 81.4)	2200 (150)	1800	27.8 - 38.7 (105.2 - 146.5)	44.9 - 63.6 (33.5 - 47.4)
SDV2020-1F13	24.37 - 33.39 (61.9 - 84.8)	2200 (150)	1800	29.4 - 40.3 (111.3 - 152.6)	47.7 - 66.4 (35.6 - 49.5)

\*Based on combinations of SDV20 pumps.

\*\*Complete model code required, see catalog on CD.

## SDV2010 Medium Pressure Double Vane Pumps

### Benefits/Features

- Two compact frame sizes available
- Low noise
- 100% tested
- Easy to convert or repair

### SDV2010

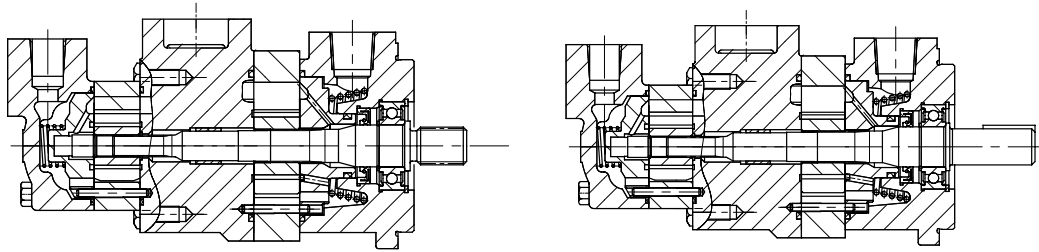

### SDV2020

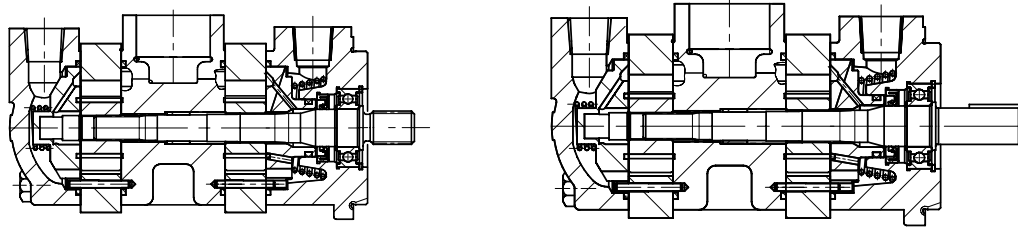

### Pump Performance Data

SDV10 Size	Output Flow (l/min)		Output Flow (GPM)		Input Power (kW)		Input Power (HP)	
	0 BAR	150 BAR	0 PSI	2000 PSI	7 BAR	150 BAR	80 PSI	2500 PSI
1	5.9	3.9	1.6	1.0	0.10	1.44	0.14	1.93
2	11.9	9.9	3.1	2.6	0.21	3.60	0.28	4.83
3	17.6	15.6	4.7	4.1	0.31	5.70	0.41	7.65
4	23.6	20.2	6.2	5.3	0.41	7.36	0.55	9.87
5	29.5	26.1	7.8	26.1	0.51	9.52	0.69	12.77
6	35.1	30.9	9.3	8.2	0.61	11.27	0.82	15.11
7	41.0	36.8	10.8	9.7	0.71	13.43	0.96	18.01

SDV20 Size	Output Flow (l/min)		Output Flow (GPM)		Input Power (kW)		Input Power (HP)	
	0 BAR	150 BAR	0 PSI	2000 PSI	7 BAR	150 BAR	80 PSI	2500 PSI
6	35.1	31.5	9.27	8.32	0.50	10.80	0.7	14.5
7	41.0	35.6	10.84	9.42	0.60	12.20	0.9	16.4
8	47.7	42.3	12.60	11.18	0.70	14.50	1.0	19.5
9	53.5	48.1	14.12	12.70	0.80	16.50	1.1	22.1
11	65.5	62.1	17.31	16.41	1.00	21.30	1.4	28.6
12	70.2	66.0	18.55	17.44	1.10	22.60	1.5	30.4
13	76.3	72.1	20.16	19.05	1.20	24.70	1.2	33.2

## SDV2010 Medium Pressure Double Vane Pumps

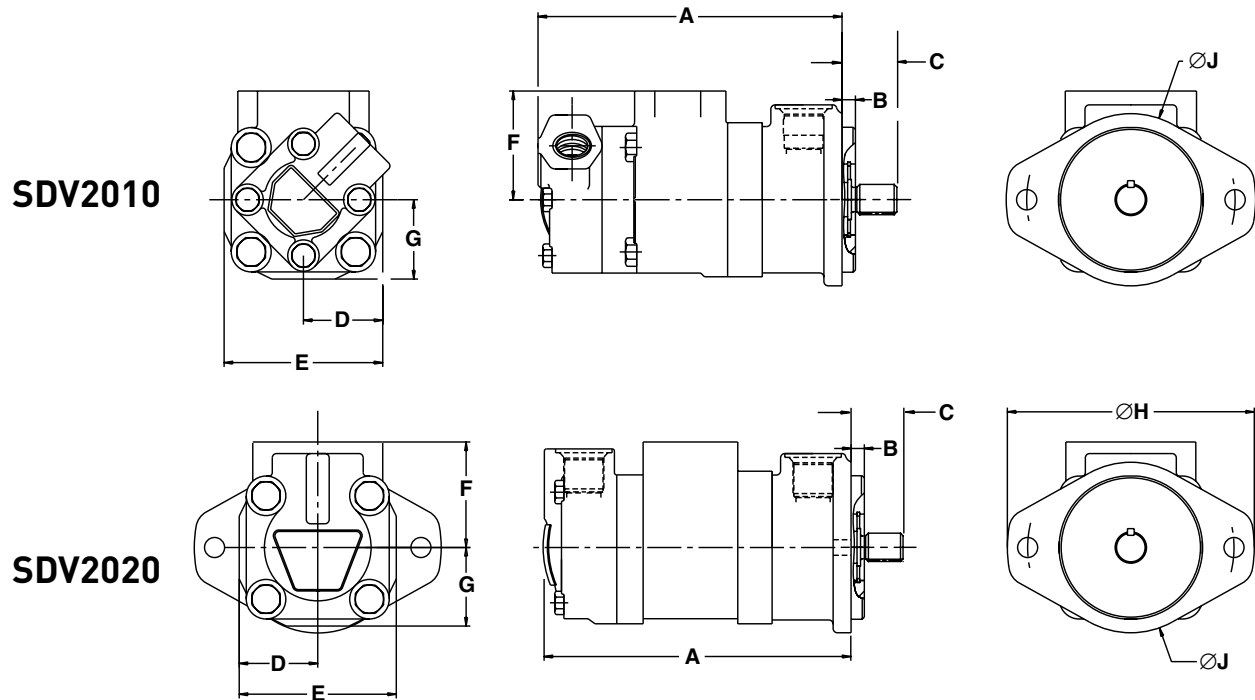

### Dimensions, inch (mm)

Ring Size	A*	B	C	D	E	F	G	ØH	ØJ
SDV2010	8.39 (213.1) to 9.17 (232.9)	0.37 (9.4)	2.31 (58.7)	2.19 (55.6)	4.38 (111.2)	3.00 (76.2)	2.19 (55.6)	8.88 (174.8)	4.75 (120.7)
SDV2020	8.41 (213.6) to 9.19 (233.4)	0.37 (9.4)	2.31 (58.7)	2.19 (55.6)	4.38 (111.2)	2.94 (74.7)	2.19 (55.6)	8.88 (174.8)	4.75 (120.7)

\* Depending on ring size



# Vane Pumps

## SDV 2010 Model Ordering Code

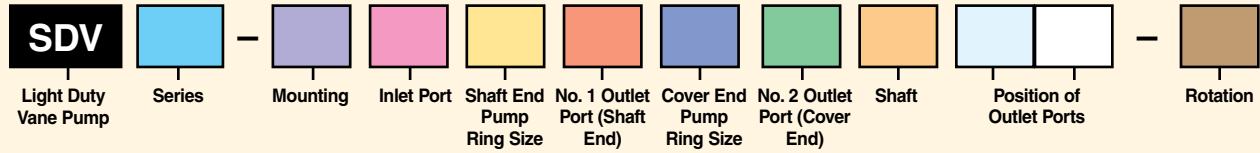

Code	Series
2010	SDV20/SDV10 Combination
2020	SDV20/SDV20 Combination

Code	Mounting
1	2 Bolt Flange, 4" Pilot (Standard)
6*	2 Bolt Flange, 3¼" Pilot

\* Available on SDV2020 only.

Code	Inlet Port Connection	
	SDV2010	SDV2020
F	4 Bolt Flange 1½" Dia.	4 Bolt Flange 2" Dia.

Code	Shaft End Pump Ring Size*
7	7 GPM (26.5 LPM)
8	8 GPM (30.3 LPM)
9	9 GPM (34.1 LPM)
11	11 GPM (41.6 LPM)
12	12 GPM (45.4 LPM)
13	13 GPM (49.2 LPM)

\* Delivery at 1200 RPM and 100 PSI.

Code	Shaft End Pump Outlet Port
S	1 1/16"-12 UNF-2B Thread
B	G3/4" BSPP

Code	Ring Size ***
1*	1 GPM (3.8 LPM)
2*	2 GPM (7.6 LPM)
3*	3 GPM (11.4 LPM)
4*	4 GPM (15.1 LPM)
5*	5 GPM (18.9 LPM)
6	6 GPM (22.7 LPM)
7	7 GPM (26.5 LPM)
8**	8 GPM (30.3 LPM)
9**	9 GPM (34.1 LPM)
11**	11 GPM (41.6 LPM)

\* SDV2010 only

\*\* SDV2020 only

\*\*\* Delivery at 1200 RPM and 100 PSI (6.9 BAR)

Code	Cover End Pump Outlet Port	
	SDV2010	SDV2020
S	3/4"-16 UNF-2B Thread	1 1/16"-12 UNF-2B Thread
B	G1/2" (BSPP)	G3/4" (BSPP)

Code	Shaft
1	Straight Keyed
11	Splined

Code	Position of Outlet Port No. 1*
A	Opposite Inlet Port
B	90° CCW from Inlet
C	In Line with Inlet
D	90° CW from Inlet

\* Viewed from cover end of pump

Code	Position of Outlet Port No. 2*
A	135° CCW from Inlet
B	45° CCW from Inlet
C	45° CW from Inlet
D	135° CW from Inlet

\* Viewed from cover end of pump

Code	Rotation*
Omit	CW
L	CCW

\* As viewed from shaft end.

## T7A Series High Performance Small Displacement Single Vane Pumps



The T Series fixed displacement vane pump is the highest performance pump of its kind. The balanced design and double lip vane technology are key features in providing a contamination resistant and reliable pump. High pressure

capabilities, extremely low noise, precise flow repeatability, and it's ability for fast pressure cycle changes make it the perfect fluid source for industrial applications.

### Pump Performance Data

Series T7AS	Displacement in <sup>3</sup> /rev (cc/rev)	Max. Outlet Pressure PSI (BAR)	Rated Drive Speed RPM	Flow @ 1800 RPM GPM (LPM)
B06	0.37 (6)	4000 (280)	3600	2.73 (10.3)
B10	0.61 (10)	4000 (280)	3600	4.68 (17.7)
B11	0.67 (11)	4000 (280)	3600	5.22 (19.8)
B13	0.79 (13)	4000 (280)	3600	6.08 (23.0)
B17	1.04 (17)	4000 (280)	3600	8.18 (31.0)
B20	1.22 (20)	4000 (280)	3600	9.43 (35.7)
B22	1.34 (22)	4000 (280)	3600	10.68 (40.4)
B25	1.53 (25)	3500 (240)	3000	11.84 (44.8)

Series T7ASW	Displacement in <sup>3</sup> /rev (cc/rev)	Max. Outlet Pressure PSI (BAR)	Rated Drive Speed RPM	Flow @ 1800 RPM GPM (LPM)
B26	1.59 (26)	4350 (300)	3600	12.39 (46.9)
B28	1.71 (28)	4350 (300)	3600	13.32 (50.4)
B30	1.83 (30)	4350 (300)	3600	14.26 (54.0)
B32	1.95 (32)	4350 (300)	3600	15.12 (57.2)
B34	2.07 (34)	4000 (280)	3000	16.13 (61.1)
B36	2.20 (36)	4000 (280)	3000	17.14 (64.9)
B40	2.44 (40)	4000 (280)	3000	19.01 (72.0)

### Markets

Material Handling	Lift Trucks
Recycling	Compactors

### Applications

### Benefits/Features

- Fully balanced pump
- 12-vane design for low pressure ripple
- Cam ring construction allows easy displacement changes
- Wide range of shafts
- SAE flanges or threaded ports
- Port orientations every 90°

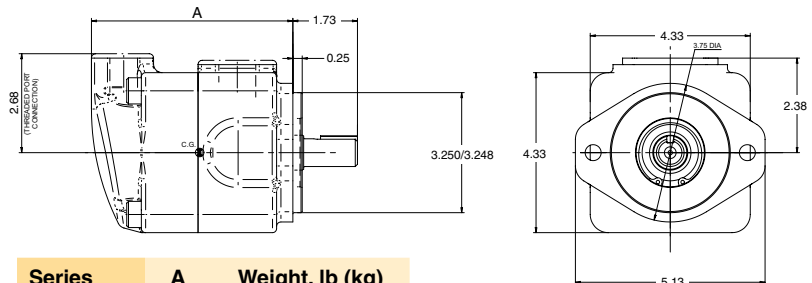

Series	A	Weight, lb (kg)
T7AS	5.45	20.9 (9.5)
T7ASW	6.33	23.9 (11.3)





# Vane Pumps

## T7A Model Ordering Code

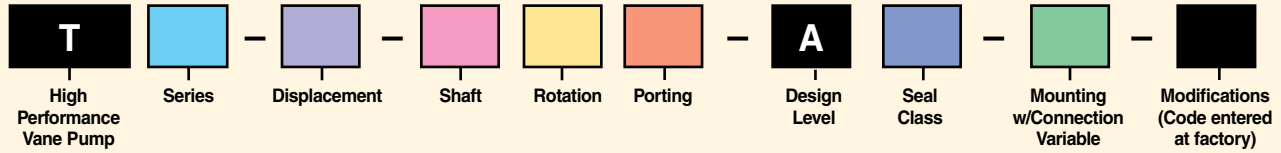

Code	Series Standard Mounting
7AS	SAE A 2-Bolt Flange (J744)
7ASW	SAE A 2-Bolt Flange (J744) Higher Displacement

7AS Codes	Displacement in <sup>3</sup> /rev (cc/rev)	7ASW Codes	Displacement, in <sup>3</sup> /rev (cc/rev)
B06	0.35 (5.73)	B26	1.59 (26.06)
B10	0.60 (9.83)	B28	1.71 (28.02)
B11	0.67 (10.98)	B30	1.83 (29.99)
B13	0.78 (12.78)	B32	1.94 (31.79)
B17	1.05 (17.21)	B34	2.07 (33.92)
B20	1.21 (19.83)	B36	2.20 (36.05)
B22	1.37 (22.45)	B40	2.44 (39.98)
B25	1.52 (24.91)		

Code	Shaft Type	
	7AS	7ASW
1	Keyed (non SAE) 0.75 Dia.	Keyed (non SAE) 0.75 Dia.
3	Splined 16/32 (SAE B) 13 Teeth	Splined 16/32 (SAE B) 13 Teeth
4	Splined 16/32 (non SAE) 9 Teeth	Splined 16/32 (non SAE) 11 Teeth

Code	Rotation*
R	CW
L	CCW

\*As viewed from shaft end.

Code	Porting Combinations*
00	
01	
02	
03	

\* P = Pressure Port; S = Suction Port

Code	Seal Class
1	S1 (Buna N)
5	S5 (fluorocarbon)*

\*Not available for 7ASW

Code	Mounting w/Connection Variables					
	7AS			7ASW		
	Type	Suction Port (S)	Pressure Port (P)	Type	Suction Port (S)	Pressure Port (P)
00	4-Bolt SAE Flange (J518) UNC Thread	1" SAE	3/4" SAE	4-Bolt SAE Flange (J518) UNC Thread	1 1/4" SAE	3/4" SAE
02	SAE Thread	1 5/16" (SAE16)	1 1/16" (SAE 12)	SAE Thread	1 5/8" (SAE20)	1 1/16" (SAE 12)
03	NPTF Thread	1 1/4" NPTF	3/4" NPTF	SAE & NPTF Threads	1 1/4" NPTF	1 1/16" (SAE 12)

## T6 Series Single, Double & Triple High Performance Vane Pumps



The T Series fixed displacement vane pump is the highest performance pump of its kind. The balanced design and double lip vane technology are key features in providing a contamination resistant and reliable pump. High pressure and speed capabilities,

extremely low noise, and a cartridge designed to prime in cold weather conditions, make this fluid power source ideal for mobile applications.

### Pump Performance Data

Single Pump Model Series	Displacement in <sup>3</sup> /rev (cc/rev)*	Max. Outlet Pressure** PSI (BAR)	Rated Drive Speed** RPM	Flow @1800 RPM and 0 PSI* GPM (LPM)	Input Horsepower @ 1800 RPM and 2000 PSI* HP (KW)
T6CM	0.66 - 6.10 (10.8 - 100)	4000 (280)	2800	5.14 - 47.56 (19.3 - 180.0)	8.45 - 57.95 (6.3 - 43.2)
T6DM	2.90 - 9.64 (47.5 - 158)	3500 (240)	2500	22.64 - 75.14 (85.7 - 284.4)	29.31 - 90.58 (21.9 - 67.5)
T6EM	8.07 - 13.85 (132.3 - 227)	3500 (240)	2200	62.92 - 108.00 (238.2 - 408.8)	78.44 - 129.09 (58.5 - 96.3)

\* Available range based on various combinations of displacements

\*\*Lower for larger displacements. See catalog.

### Markets

### Applications

Industrial	Injection Molding
Construction	Wheel Loader, ADTs, Fan Drives
Recycling	Shredders, Balers, Compactors, Vacuum Truck Systems, Refuse Trucks - ASL, Rear Loaders

## T6 Series Single, Double & Triple High Performance Vane Pumps

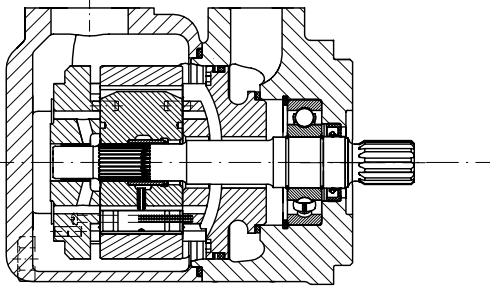

### Benefits/Features

- Mobile cartridge designed for cold start-ups
- Wide range of displacements
- Low noise provides machine operator safety
- Speed range from 400 to 2800 rpm
- Large flow within a small envelope
- Double shaft seal option allows direct mounting to gearboxes

### Pump Performance Data

T6CM/CP	Output Flow (lpm) @ 1800 RPM			Output Flow (GPM) @ 1800 RPM			Input Power (kW)			Input Power (HP)		
	0 BAR	140 BAR	280 BAR	0 PSI	2000 PSI	3500 PSI	7 BAR	140 BAR	280 BAR	100 PSI	2000 PSI	3500 PSI
B03	19.3	13.6	–	5.1	3.6	–	1.6	6.3	–	2.1	8.5	–
B05	31.0	25.0	21.2	8.2	6.6	5.6	1.7	8.9	14.6	2.3	12.0	19.6
B06	38.2	32.6	28.4	10.1	8.6	7.5	1.8	10.7	17.6	2.4	14.3	23.6
B08	47.3	41.6	37.5	12.5	11.0	9.9	1.9	12.8	21.3	2.5	17.1	28.5
B10	61.3	55.6	51.5	16.2	14.7	13.6	2.1	16.0	26.8	2.8	21.4	36.0
B12	66.6	60.9	56.8	17.6	16.1	15.0	2.1	17.2	29.0	2.8	23.1	38.9
B14	82.9	76.8	73.1	21.9	20.3	19.3	2.3	20.9	35.5	3.1	28.0	47.6
B17	104.8	99.2	95.0	27.7	26.2	25.1	2.5	26.0	44.4	3.4	34.8	59.5
B20	114.7	109.0	103.7	30.3	28.8	27.4	2.7	28.3	48.4	3.6	37.9	64.9
B22	126.4	120.7	116.6	33.4	31.9	30.8	2.8	30.9	53.1	3.8	41.5	71.2
B25	142.7	137.0	132.9	37.7	36.2	35.1	3.0	34.7	59.6	4.0	46.5	79.9
B28	159.8	154.1	151.0	42.23	40.7	39.9	3.2	38.6	57.2	4.3	51.7	76.7
B31	180.0	174.1	171.5	47.56	46.0	45.3	3.4	43.3	64.2	4.6	58.0	86.1

\*\* T6CP not available in sizes B03 through B12

T6DM	Output Flow (lpm) @ 1800 RPM			Output Flow (GPM) @ 1800 RPM			Input Power (kW)			Input Power (HP)		
	0 BAR	140 BAR	300 BAR	0 PSI	2000 PSI	3500 PSI	7 BAR	140 BAR	300 BAR	100 PSI	2000 PSI	3500 PSI
B14	85.5	77.2	71.2	22.6	20.4	18.8	3.0	21.9	36.8	4.0	29.3	49.3
B17	104.8	96.5	90.5	27.7	25.5	23.9	3.2	26.2	44.4	4.3	35.2	59.6
B20	118.9	110.5	104.5	31.4	29.2	27.6	3.4	29.5	50.1	4.5	39.5	67.2
B24	143.1	134.7	128.7	37.8	35.6	34.0	3.7	35.0	59.9	4.9	47.0	80.3
B28	161.6	153.3	146.9	42.7	40.5	38.8	3.9	39.3	67.3	5.2	52.7	90.2
B31	176.8	168.8	162.4	46.7	44.6	42.9	4.0	42.8	73.5	5.4	57.4	98.6
B35	199.8	191.5	185.5	52.8	50.6	49.0	4.3	48.1	82.7	5.8	64.5	110.9
B38	216.5	208.2	202.1	57.2	55.0	53.4	4.5	52.0	89.4	6.0	69.7	119.9
B42	244.9	236.6	230.5	64.7	62.5	60.9	4.8	58.5	100.8	6.5	78.4	135.2
B45	262.3	254.0	247.9	69.3	67.1	65.5	5.0	62.4	107.8	6.7	83.7	144.6
B50	284.3	276.3	271.8	75.1	73.0	71.8	5.3	67.6	100.3	7.1	90.6	134.5

Note: See catalog on CD for additional cartridge options and specific displacement operating parameters.

## T6 Series Single, Double & Triple High Performance Vane Pumps

### Pump Performance Data

T6EM	Output Flow (lpm) @ 1800 RPM			Output Flow (GPM) @ 1800 RPM			Input Power (kW)			Input Power (HP)		
	0 BAR	140 BAR	240 BAR	0 PSI	2000 PSI	3500 PSI	7 BAR	140 BAR	300 BAR	100 PSI	2000 PSI	3500 PSI
042	238.1	228.6	221.4	62.9	60.4	58.5	6.0	58.5	84.9	8.1	78.4	113.8
045	256.2	246.8	239.6	67.7	65.2	63.3	5.1	61.2	105.5	6.9	82.1	141.5
050	285.4	275.5	268.7	75.4	72.8	71.0	5.4	67.9	117.2	7.3	91.0	157.2
052	296.7	286.9	280.1	78.4	75.8	74.0	5.6	70.5	121.8	7.5	94.5	163.3
062	353.9	344.4	337.2	93.5	91.0	89.1	6.3	83.7	144.9	8.4	112.2	194.3
066	383.8	374.3	367.1	101.4	98.9	97.0	6.6	90.5	156.9	8.8	121.4	210.4
072	408.8	399.3	392.1	108.0	105.5	103.6	6.9	96.3	166.9	9.2	129.1	223.8

Note: See catalog on CD for additional cartridge options and specific displacement operating parameters.

### T6CM

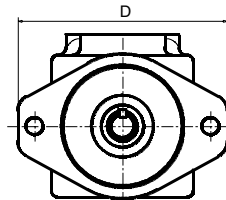
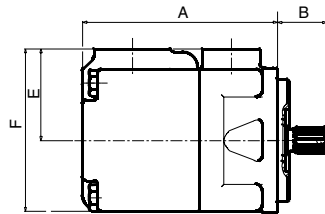

### T6DM

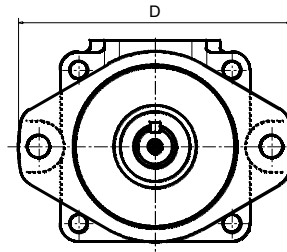
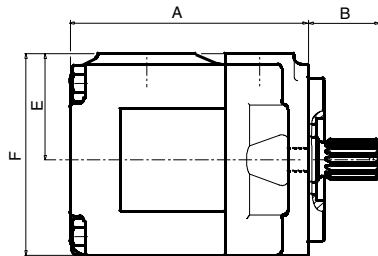

### T6EM

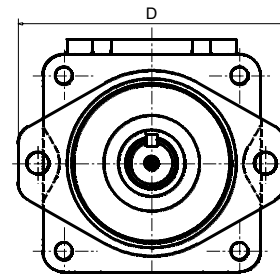
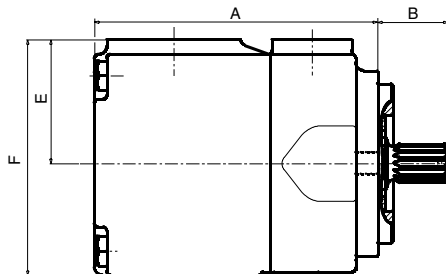

### Dimensions, inch (mm)

Series	A	B	D	E	F	Weight, lb (kg)
T6CM	6.36 (161.5)	2.81 (71.4)	6.87 (174.5)	3.00 (76.2)	5.31 (134.9)	34.0 (15.5)
T6DM	7.28 (184.9)	3.29 (83.6)	8.36 (212.3)	3.25 (82.6)	6.17 (156.7)	53.0 (24.0)
T6EM	8.87 (225.3)	3.58 (90.9)	8.39 (213.1)	3.88 (98.6)	7.38 (187.5)	95.4 (43.4)



# Vane Pumps

## T6 Model Ordering Code

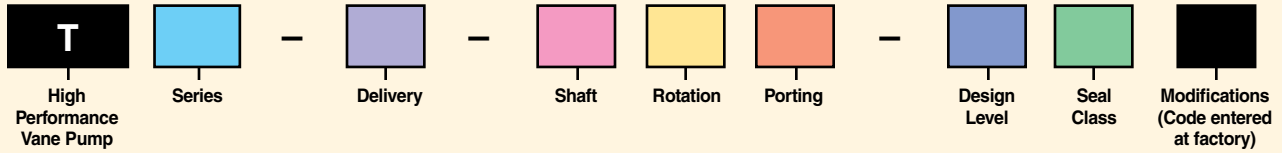

Code	Series Description
6CM	Size C, Mobile 1 Shaft Seal
6CP	Size C, Mobile 2 Shaft Seals
6DM	Size D, Mobile 1 Shaft Seal
6DP	Size D, Mobile 2 Shaft Seals
6EM	Size E, Mobile 1 Shaft Seal
6EP	Size E, Mobile 2 Shaft Seals

Delivery					
6C Codes	Delivery** GPM (LPM)	6D Codes	Delivery ** GPM (LPM)	6E Codes	Delivery** GPM (LPM)
B03*	3.42 (12.9)	B14	15.09 (57.1)	042	41.94 (158.8)
B05*	5.45 (20.6)	B17	18.45 (69.8)	045	46.15 (174.7)
B06*	6.76 (25.6)	B20	20.93 (79.2)	050	50.25 (190.2)
B08*	8.36 (31.6)	B24	25.20 (95.4)	052	52.25 (197.8)
B10*	10.81 (40.9)	B28	28.44 (107.7)	062	62.36 (236.1)
B12*	11.76 (44.5)	B31	31.16 (118.0)	066	67.62 (256.0)
B14	14.58 (55.2)	B35	35.19 (133.2)	072	72.00 (272.5)
B17	18.48 (70.0)	B38	38.14 (144.4)		
B20	20.23 (76.6)	B42	43.12 (163.2)		
B22	22.28 (83.9)	B45	46.19 (174.9)		
B25	25.14 (95.2)	B50	50.09 (189.6)		
B28	27.90 (105.6)				
B31	31.70 (120.0)				

\* Not available on T6CP  
 \*\* At 0 PSI (0 BAR) and 1200 RPM

Code	Shaft Type			
	6CM	6CP	6DM, 6DP	6EM, 6EP
1	Keyed SAE B		Keyed SAE C	Keyed SAE CC
2	Keyed (non SAE)	Keyed (non SAE)	Keyed (non SAE)	Keyed (non SAE)
3	Splined SAE B	Splined SAE C	Splined***	Splined***
4	Splined SAE BB		Splined (non SAE)	Splined SAE CC
T			Splined SAE J718c	Splined SAE J718c

\* SAE C for 6\*M, non SAE for 6\*P

Code	Rotation*
R	CW
L	CCW

\* As viewed from shaft end.

Code	Porting Combinations*
00	
01	
02	
03	

\* P = Pressure Port; S = Suction Port

Code	Design Level
A	T6CP only
B	T6EM, T6EP
C	All Others

Code	Seal Class
1	S1 (Buna N)
4	S4 (EPDM)
5	S5 (fluorocarbon)

*Pumps are also available in thru-drive version. See Catalog on CD.*

= Not Available

## T7 Series Single, Double & Triple High Performance Vane Pumps



The high performance T Series fixed displacement vane pumps have been specially designed to provide high flows within a small envelope. The balanced design and double lip vane technology are key features in providing

a contamination resistant and reliable pump. High pressure and speed capabilities, extremely low noise, and a cartridge designed to prime in cold weather conditions, make this fluid power source ideal for Mobile applications.

### Pump Performance Data

Double Pump Model Series	Displacement in <sup>3</sup> /rev (cc/rev)*	Max. Outlet Pressure** PSI (BAR)	Rated Drive Speed RPM	Flow @1800 RPM and 0 PSI* GPM (LPM)	Input Horsepower @ 1800 RPM and 2000 PSI* HP (KW)
T6CCM	1.32 - 12.20 (21.6 - 200)	4000 (280)	2800	10.3 - 95.1 (39.0 - 360.0)	16.9 - 115.9 (12.6 - 86.4)
T6DCM	3.56 - 15.74 (58.3 - 258)	4000 (280)	2500	27.8 - 122.7 (105.2 - 464.5)	37.8 - 148.5 (28.2 - 110.7)
T6ECM	8.73 - 19.95 (143.1 - 327)	4000 (280)	2200	68.1 - 155.6 (257.8 - 589.0)	86.9 - 187.0 (64.8 - 139.4)
T6EDM	10.97 - 23.49 (179.7 - 385)	3500 (240)	2200	85.5 - 183.1 (147.6 - 693.1)	107.7 - 219.7 (80.3 - 163.8)

\* Available range based on various combinations of displacements

\*\*Lower for larger displacements. See catalog.

### Markets

Industrial	Injection Molding
Construction	Wheel Loader, Fan Drives
Recycling	Shredders, Balers, Compactors, Vacuum Truck Systems, Refuse Trucks - ASL, Rear Loaders

### Applications

### T Series Double

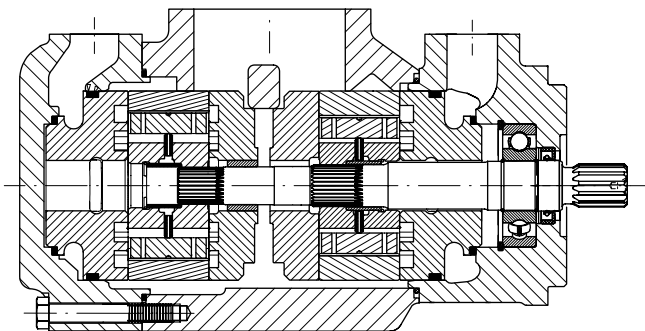

### Benefits/Features

- Low noise
- SAE or ISO standards
- One-piece shaft (no internal torque limitations)
- One inlet
- 32 porting orientations available
- Wide displacement possibility
- High power to weight ratio
- Wide range of options for shafts, threads and pilots
- Mobile cartridge design for cold start conditions

## T7 Series Single, Double & Triple High Performance Vane Pumps

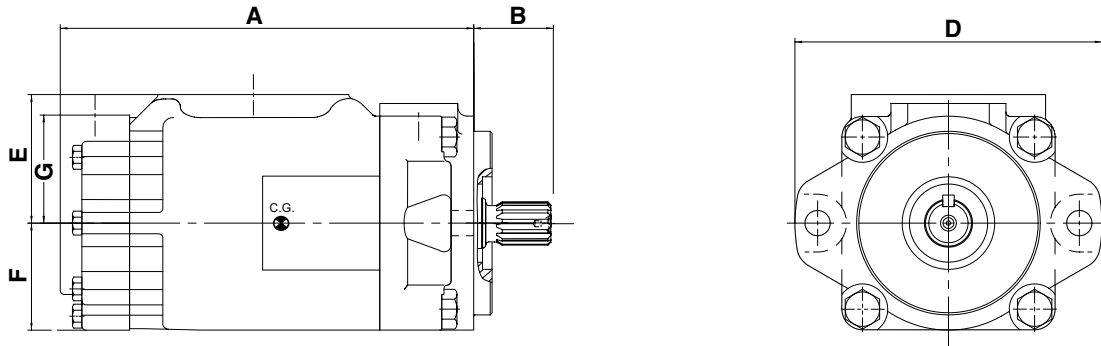

### Dimensions, inch (mm)

Series	A	B max	D	E	F	Weight, kg (lb)
T6CCM	10.46 (265.7)	2.81(71.4)	6.87 (174.5)	3.31 (84.1)	2.88 (73.2)	57.3 (26.0)
T6DCM	11.26 (286.0)	3.29 (83.6)	8.36 (212.3)	3.50 (88.9)	2.92 (74.2)	80.7 (36.7)
T6ECM	13.06 (331.7)	3.58 (90.9)	8.39 (213.1)	4.03 (102.4)	3.50 (88.9)	121.0 (55.0)
T6EDM	14.22 (361.2)	3.58 (90.9)	8.39 (213.1)	4.03 (102.4)	3.50 (88.9)	145.5 (66.1)

# Vane Pumps

## T7 Model Ordering Code

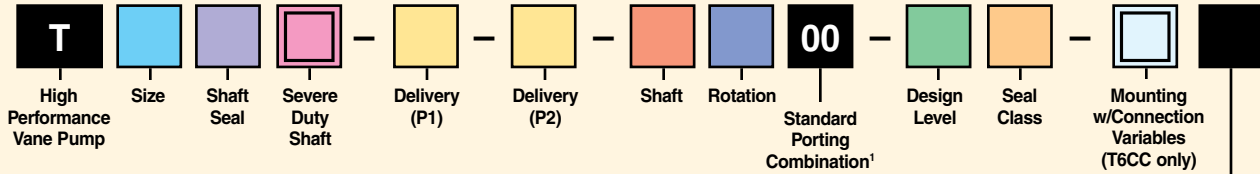

Size Code	
6CC	
6DC	
6EC	
6ED	

Code	Shaft Seal
M	Mobile 1 Seal
P	Mobile 2 Seals

Code	Severe Duty
Omit	Standard
W*	Severe Duty

\*Available on T6CCM and T6DCM only.

Size	Delivery (See Table Below)	
	P1	P2
6CC	Use Codes for 6C	Use Codes for 6C
6DC	Use Codes for 6D	Use Codes for 6C
6EC	Use Codes for 6E	Use Codes for 6C
6ED	Use Codes for 6E	Use Codes for 6D

Code	Shaft (See catalog on CD for severe duty options)				
	6CCM	6CCP	6DCM	6DCP 6ECP, 6EDP	6ECM 6EDM
1	Keyed (non SAE)		Keyed SAE C		Keyed SAE CC
2			Keyed (non SAE)		Keyed (non SAE)
3	Splined SAE BB	Splined (non SAE)	Splined SAE C	Splined (non SAE)	Splined SAE C
4		Splined SAE BB	Splined (non SAE)		Splined SAE CC
5	Splined SAE B				
6		Splined (non SAE)			
T					Splined SAE J718c

Modifications (Code entered at factory)

Code	Rotation*
R	CW
L	CCW

\*As viewed from shaft end.

Code	Design Level
D	T6CC only
C	All Others

Code	Seal Class
1	S1 (Buna N)
4	S4 (EPDM)
5	S5 (fluorocarbon)

Code	Connection Variables		
	T6CC		
	P1	P2	S
00	1"	1"	3"
01	1"	3/4"	3"
10	1"	1"	2 1/2"
11	1"	3/4"	2 1/2"

P = Pressure Port; S = Suction Port

### Delivery

6C Codes	Delivery* GPM (LPM)	6D Codes	Delivery* GPM (LPM)	6E Codes	Delivery* GPM (LPM)
B03	3.42 (12.9)	B14	15.09 (57.1)	042	41.94 (158.8)
B05	5.45 (20.6)	B17	18.45 (69.8)	045	46.15 (174.7)
B06	6.76 (25.6)	B20	20.93 (79.2)	050	50.25 (190.2)
B08	8.36 (31.6)	B24	25.20 (95.4)	052	52.25 (197.8)
B10	10.81 (40.9)	B28	28.44 (107.7)	062	62.36 (236.1)
B12	11.76 (44.5)	B31	31.16 (118.0)	066	67.62 (256.0)
B14	14.58 (55.2)	B35	35.19 (133.2)	072	72.00 (272.5)
B17	18.48 (70.0)	B38	38.14 (144.4)		
B20	20.23 (76.6)	B42	43.12 (163.2)		
B22	22.28 (84.3)	B45	46.19 (174.9)		
B25	25.14 (95.2)	B50	50.09 (189.6)		
B28	27.90 (105.6)				
B31	31.70 (120.0)				

\* At 0 PSI (0 BAR) and 1200 RPM

†Many other combinations are available See catalog on CD.

☐ = Not Available

☐ = Omit if not required or to select standard option coded "omit".



## T67 Series High Performance Vane Pumps



The high performance T Series fixed displacement vane pumps have been specially designed to provide high flows within a small envelope. The balanced design and double lip vane technology are key features in providing a contamination resistant and reliable pump. High pressure and

speed capabilities, extremely low noise, and a cartridge designed to prime in cold weather conditions, make this fluid power source ideal for mobile applications.

### Pump Performance Data

Triple Pump Model Series	Displacement in <sup>3</sup> /rev (cc/rev)*	Max. Outlet Pressure** PSI (BAR)	Rated Drive Speed RPM	Flow @1800 RPM and 0 PSI* GPM (LPM)	Input Horsepower @ 1800 RPM and 2000 PSI* HP (KW)
T6DCCM	4.22 - 21.85 (69.1 - 358)	4000 (280)	2500	32.9 - 170.3 (124.5 - 644.7)	46.2 - 206.5 (34.5 - 154.0)
T6EDCM/S	11.63 - 29.60 (190.5 - 485)	4000 (280)	2200	90.7 - 230.7 (343.3 - 873.3)	116.2 - 277.6 (86.7 - 207.0)

\* Available range based on various combinations of displacements.

\*\* Lower for larger displacements. See catalog.

### Markets

Industrial	Injection Molding
Construction	Wheel Loader, Fan Drives
Recycling	Shredders, Balers, Compactors, Vacuum Truck Systems, Refuse Trucks - ASL, Rear Loaders

### Applications

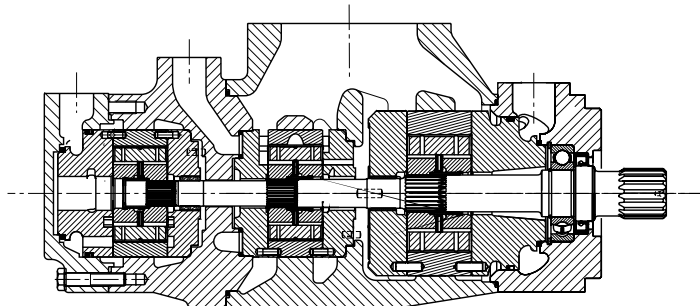

### Benefits/Features

- Low noise
- SAE or ISO standards
- One-piece shaft (no internal torque limitations)
- One inlet
- 128 porting orientations available
- Many displacement combinations per stage
- High power to weight ratio
- Wide range of options for shafts, threads and pilots
- Mobile cartridge design for cold start conditions

## T67 Series High Performance Vane Pumps

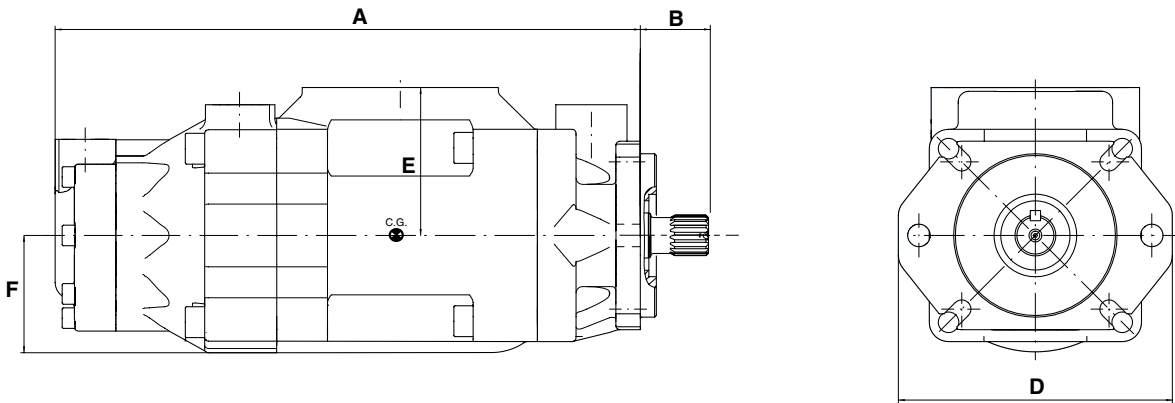

### Dimensions, inch (mm)

Series	A	B max.	D	E	F	Weight, lb (kg)
T6DCC	15.90 (403.9)	3.53 (89.7)	8.36 (212.3)	5.00 (127.0)	3.35 (85.1)	134.5 (61.1)
T6EDC	18.42 (467.9)	3.94 (100.1)	10.75 (273.1)	—	—	220.4 (100.2)



# Vane Pumps

## T67 Model Ordering Code

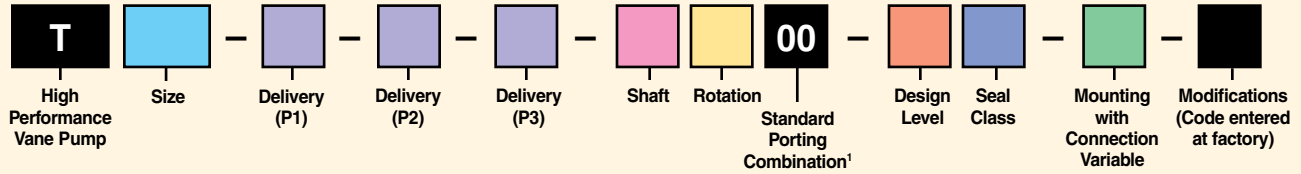

Size Code
6DCCM
6EDCS
6EDCM

Note: T6EDCS (SAE pilot)  
T6EDCM (ISO pilot)

Size	Delivery (See Table Below)		
	P1	P2	P3
6DCCM	Use Codes for 6D	Use Codes for 6C	Use Codes for 6C
6EDCS 6EDCM	Use Codes for 6E	Use Codes for 6D	Use Codes for 6C

Code	Shaft		
	6DCCM	6EDCM	6EDCS
1	Keyed (non SAE)	Keyed ISO G45N - 3019-2	
2	Keyed SAE CC		Keyed SAE D&E
3	Splined SAE C	Splined SAE D&E	Splined SAE D&E
4	Splined SAE CC		
6	Splined (non SAE)		

Code	Rotation*
R	CW
L	CCW

\*As viewed from shaft end.

Code	Design Level
A	6EDC
B	6DCC

Code	Seal Class
1	S1 (Buna N)
4	S4 (EPDM)
5	S5 (fluorocarbon)

Code	Connection Variables
Code 6DCCM	
M0	P3 = 1" Metric
M1	P3 = 3/4" Metric
00	P3 = 1" UNC
01	P3 = 3/4" UNC
Code 6EDC/S/M	
F0*	P3 = 1" SAE
F1*	P3 = 3/4" SAE
P0**	P3 = 1" SAE
P1**	P3 = 3/4" SAE

\*"F" is standard

\*\*"P" 4 holes for external support

### Delivery

6C Codes	Delivery* GPM (LPM)	6D Codes	Delivery * GPM (LPM)	6E Codes	Delivery* GPM (LPM)
B03	3.42 (12.9)	B14	15.09 (57.1)	042	41.94 (158.8)
B05	5.45 (20.6)	B17	18.45 (69.8)	045	46.15 (174.7)
B06	6.76 (25.6)	B20	20.93 (79.2)	050	50.25 (190.2)
B08	8.36 (31.6)	B24	25.20 (95.4)	052	52.25 (197.8)
B10	10.81 (40.9)	B28	28.44 (107.7)	062	62.36 (236.1)
B12	11.76 (44.5)	B31	31.16 (118.0)	066	67.62 (256.0)
B14	14.58 (55.2)	B35	35.19 (133.2)	072	72.00 (272.5)
B17	18.48 (70.0)	B38	38.14 (144.4)		
B20	20.23 (76.6)	B42	43.12 (163.2)		
B22	22.28 (83.3)	B45	46.19 (174.9)		
B25	25.14 (95.2)	B50	50.09 (189.6)		
B28	27.90 (105.6)				
B31	31.70 (120.0)				

\* At 0 PSI (0 BAR) and 1200 RPM

\*Many other combinations are available See catalog on CD.

□ = Not Available

## T6H/T7H Hybrid Technology Variable Piston Fixed Vane Pumps



The hybrid pump is a combination of fixed displacement vane pump B, C, D cartridges combined with a variable cartridge of PV20 or PV29 piston pump. The cartridges are driven by a common shaft without

coupling in between they have a large common suction port and two or three independent outlet ports: one for the piston, one or two for the vane pump.

### Pump Performance Data

Single Pump Model Series***	Displacement in <sup>3</sup> /rev (cc/rev)*	Max. Outlet Pressure** PSI (BAR)	Rated Drive Speed** RPM	Flow @1800 RPM and 0 PSI* GPM (LPM)	Input Horsepower @ 1800 RPM and 2000 PSI* HP (KW)
T6H20B	0.35 - 5.67 (5.7 - 92.9)	3500 (240)	2600	23.76 - 44.78 (89.9 - 169.5)	31.5 - 56.1 (23.5 - 41.8)
T6H20C	0.66 - 8.72 (10.8 - 142.9)	3500 (240)	2600	26.14 - 68.56 (99.0 - 259.5)	36 - 85.5 (26.8 - 63.8)
T6H29B	0.35 - 6.83 (5.7 - 111.9)	3000 (210)	2400	31.76 - 52.78 (120.2 - 199.8)	41 - 65.5 (30.6 - 48.8)
T6H29C	0.66 - 9.88 (10.8 - 161.9)	3000 (210)	2400	34.14 - 76.56 (129.2 - 289.8)	45.5 - 95 (33.9 - 70.8)
T6H29D	2.90 - 13.42 (47.5 - 219.9)	3000 (210)	2400	51.64 - 104.14 (195.5 - 394.2)	66.3 - 127.6 (49.4 - 95.2)
T6H29DB	32.46 - 16.47 (53.2 - 269.9)	3000 (210)	2400	56.78 - 151.7 (214.9 - 574.2)	70.3 - 156.1 (52.4 - 116.4)

\* Piston pump at full displacement.

\*\* Lower for larger displacements; see catalog.

\*\*\* See catalog on CD for complete information.

### Pump Performance Data

Tables show data by cam ring size for van portion only (does not include piston portion).

T6H**B	Output Flow (lpm) @ 1800 RPM			Output Flow (GPM) @ 1800 RPM			Input Power (kW) @ 1800 RPM			Input Power (HP) @ 1800 RPM		
	0 BAR	140 BAR	320 BAR	0 PSI	2000 PSI	4350 PSI	7 BAR	140 BAR	320 BAR	100 PSI	2000 PSI	4350 PSI
B02	10.4	8.8	6.8	2.76	2.33	1.8	0.6	3.0	6.0	0.74	4.02	8.1
B03	17.6	16.0	14.0	4.66	4.23	3.7	0.6	4.7	9.6	0.85	6.24	12.93
B04	23.1	21.4	19.4	6.09	5.66	5.13	0.7	5.9	12.3	0.94	7.9	16.55
B05	28.6	27.0	25.0	7.56	7.13	6.6	0.8	7.2	15.1	1.02	9.62	20.29
B06	35.7	34.0	32.0	9.42	8.99	8.46	0.8	8.8	18.6	1.13	11.79	25
B07	40.5	38.9	36.9	10.7	10.27	9.74	0.9	9.9	21.1	1.2	13.29	28.26
B08	44.8	43.2	41.2	11.84	11.41	10.88	0.9	10.9	23.2	1.27	14.62	31.15
B10	57.2	55.6	53.6	15.12	14.69	14.16	1.1	13.8	29.4	1.46	18.45	39.48
B12	73.8	72.2	70.2	19.5	19.07	18.54	1.3	17.6	37.7	1.72	23.55	50.58
B15	90.0	88.4	86.6	23.78	23.35	22.88	1.5	21.3	42.8	1.97	28.55	57.35

\*At 280 BAR (4060 PSI)

### Markets

Industrial

### Applications

Injection Molding

## T6H/T7H Hybrid Technology Variable Piston Fixed Vane Pumps

### Pump Performance Data

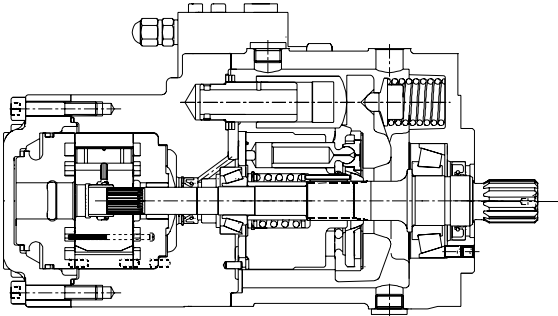

### Benefits/Features

- Very compact
- High pressure ratings
- Low noise
- Independent outlets for fixed and variable flow allow simultaneous cycles
- Internal or external drain
- Choice of controls
- Wide range of acceptable fluids

Tables show data by cam ring size for vane portion only (does not include piston portion).

T6H**C	Output Flow (lpm) @ 1800 RPM			Output Flow (GPM) @ 1800 RPM			Input Power (kW) @ 1800 RPM			Input Power (HP) @ 1800 RPM		
	Size	0 BAR	140 BAR	320 BAR	0 PSI	2000 PSI	3500 PSI	7 BAR	140 BAR	320 BAR	100 PSI	2000 PSI
*03	19.5	13.7	—	5.14	3.61	—	1.6	6.3	10.0	2.11	8.45	13.38
*05	31.0	25.2	21.0	8.18	6.65	5.56	1.7	8.9	14.6	2.29	12	19.59
*06	38.3	32.6	28.4	10.13	8.6	7.51	1.8	10.6	17.6	2.4	14.28	23.57
*08	47.5	41.7	37.6	12.55	11.02	9.93	1.9	12.8	21.3	2.54	17.11	28.53
*10	61.4	55.6	51.5	16.22	14.69	13.6	2.1	15.9	26.8	2.76	21.38	36
*12	66.8	61.0	56.9	17.64	16.11	15.02	2.1	17.2	29.0	2.84	23.05	38.92
*14	82.8	77.0	72.9	21.88	20.35	19.26	2.3	20.9	35.5	3.09	27.99	47.56
*17	105.0	99.2	95.0	27.73	26.2	25.11	2.6	26.0	44.4	3.43	34.81	59.51
*20	114.8	109.0	103.8	30.34	28.81	27.42	2.7	28.2	48.4	3.58	37.86	64.85
*22	126.5	120.7	116.6	33.43	31.9	30.81	2.8	30.9	53.1	3.76	41.47	71.16
*25	142.7	136.9	132.8	37.71	36.18	35.09	3.0	34.6	59.6	4.01	46.46	79.9
*28	159.8	154.1	151.2	42.23	40.7	39.94	3.2	38.6	57.2	4.27	51.74	76.73
*31	180.0	174.2	171.3	47.56	46.03	45.27	3.4	43.2	64.2	4.58	57.95	86.06

\*At 210 BAR (3000 PSI)

T6H29D	Output Flow (lpm) @ 1800 RPM			Output Flow (GPM) @ 1800 RPM			Input Power (kW) @ 1800 RPM			Input Power (HP) @ 1800 RPM		
	Size	0 BAR	140 BAR	320 BAR	0 PSI	2000 PSI	3500 PSI	7 BAR	140 BAR	320 BAR	100 PSI	2000 PSI
014	85.7	77.4	71.2	22.64	20.46	18.82	3.0	21.9	36.8	4.02	29.31	49.34
017	104.8	96.5	90.3	27.68	25.50	23.86	3.2	26.2	44.5	4.31	35.20	59.64
020	118.8	110.6	104.4	31.39	29.21	27.57	3.4	29.5	50.1	4.53	39.52	67.21
024	143.1	134.9	128.7	37.81	35.63	33.99	3.7	35.1	59.9	4.91	47.02	80.32
028	161.5	153.2	147.0	42.66	40.48	38.84	3.9	39.3	67.3	5.19	52.68	90.23
031	176.9	168.7	162.5	46.75	44.57	42.93	4.1	42.8	73.5	5.43	57.45	98.58
035	199.8	191.6	185.4	52.79	50.61	48.97	4.3	48.1	82.7	5.78	64.50	110.91
038	216.5	208.3	202.1	57.21	55.03	53.39	4.5	51.9	89.4	6.04	69.66	119.94
042	244.8	236.6	230.4	64.68	62.5	60.86	4.8	58.4	100.8	6.47	78.37	135.19
045	262.3	254.0	247.8	69.29	67.11	65.47	5.0	62.5	107.8	6.74	83.75	144.61
050	284.4	276.2	271.7	75.14	72.96	71.78	5.3	67.5	100.3	7.08	90.58	134.54

\* At 3000 PSI

## T6H/T7H Hybrid Technology Variable Piston Fixed Vane Pumps

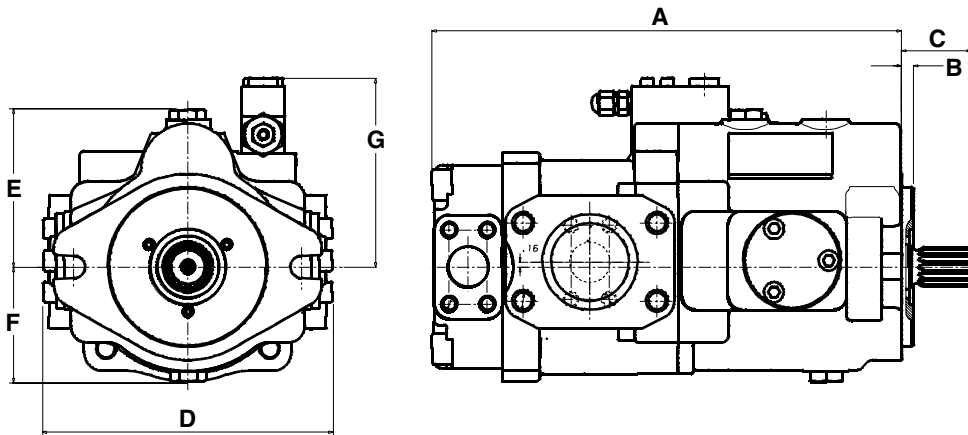

### Dimensions, inch (mm)

Series	A	B max	C Max.	D Max	E	F	G Max.	Weight, kg (lb)
T6H20B/C	12.64 (321.1)	0.31 (7.9)	2.75 (69.8)	8.86 (225.0)	4.54 (115.3)	3.19 (81.0)	6.77 (172.0)	81.6 (37.1)
T6H29B/C	13.27 (337.1)	0.375 (9.5)	3.31 (84.1)	9.056 (230.0)	4.91 (124.7)	3.59 (91.2)	5.9 (149.9)	108.0 (49.1)
T6H29D	14.70 (373.4)	0.375 (9.5)	3.31 (84.1)	9.06 (230.1)	4.92 (125.0)	3.59 (91.2)	5.9 (149.9)	132.2 (60.1)
T6H29DB	19.30 (490.2)	0.375 (9.5)	3.31 (84.1)	9.06 (230.1)	4.95 (125.7)	3.59 (91.2)	5.9 (149.9)	158.7 (72.1)



# Vane Pumps

## T6H/T7H Model Ordering Code

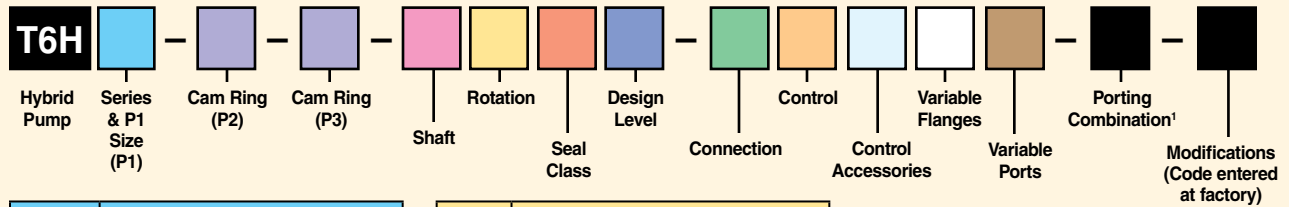

Code	P1 Size
20B 20C	2.62 in <sup>3</sup> /rev (42.9 cc/rev)
29B 29C 29D 29DB	3.78 in <sup>3</sup> /rev (62.0 cc/rev)

Size	P2 & P3 Cam Ring Size (See Table Below)	
	P2	P3*
T6H20B	Use B Codes	
T6H20C	Use C Codes	
T6H29B	Use B Codes	
T6H29C	Use C Codes	
T6H29D	Use D Codes	
T6H29DB	Use D Codes	Use B Codes

\*P3 required for double pumps (DB) only.  
Omit for single pumps.

Code	Shaft	
	T6H20	T6H29
1	Keyed SAE BB	Keyed SAE C
3	Splined SAE C	Splined SAE C
4	Splined SAE BB	
5	Keyed SAE C	

Code	Rotation*
R	CW
L	CCW

\*As viewed from shaft end.

Code	Seal Class
1	S1 (Buna N)
5	S5 (fluorocarbon)

Code	Design Level
C	T6H20C
B	All Other Sizes

Code	Connection (Drain + Vent.)
0	Ext. Drain + UNF Thread
2	Ext. Drain + BSPP Thread
3	Int. Drain + UNF Thread
4	Int. Drain + BSPP Thread

Code	Control
C	Compensator
F	RC Pilot Operated Compensator
L	RC Pilot Operated Compensator, Load Sensing
X*	RC Pilot Operated Compensator with Vent Valve 24 VDC

\*Use with external drain only.

Code	Control Accessories
0	Maximum Flow
9	90% Max Flow
8	80% Max Flow
7	70% Max Flow
6	60% Max Flow
5	50% Max Flow

Code	Variable Flange Connection
0	SAE 4 Bolt Flange (J518c), UNC Thread
M	SAE 4 Bolt Flange (J518c), Metric Thread

Code	Variable Port		
	B & C P2	D P2	DB P3
0	1"	1¼"	1"
1	¾"		¾"

### Cam Ring Codes

B Codes	Delivery GPM (LPM)	C Codes	Delivery GPM (LPM)	D Codes	Delivery GPM (LPM)
B02	1.84 (7.0)	*03	3.42 (12.9)	014	15.09 (57.1)
B03	3.11 (11.8)	*05	5.45 (20.6)	017	18.45 (69.8)
B04	4.06 (15.4)	*06	6.75 (25.6)	020	20.93 (79.2)
B05	5.04 (19.1)	*08	8.37 (31.7)	024	25.20 (95.4)
B06	6.28 (23.8)	*10	10.81 (40.9)	028	28.44 (107.7)
B07	7.13 (27.0)	*12	11.76 (44.5)	031	31.16 (118.0)
B08	7.89 (29.9)	*14	14.58 (55.2)	035	35.19 (133.2)
B10	10.08 (38.1)	*17	18.48 (70.0)	038	38.14 (144.4)
B12	13.00 (49.2)	*20	20.23 (76.6)	042	43.12 (163.2)
B15	15.85 (60.0)	*22	22.29 (84.4)	045	46.19 (174.9)
		*25	25.14 (95.2)	050	50.09 (189.6)
		*28	28.15 (106.6)		
		*31	31.70 (120.0)		

\* 0 = uni-rotational; B = bi-rotational

\*Several combinations are available. See Catalog on CD.

☐ = Not Available







# Motors

*Page*

**(M)** = Mobile **(I)** = Industrial **(B)** = Mobile & Industrial

<b>(M)</b>	<b>F11 Small Frame Fixed Displacement Bent-Axis Pumps/Motors</b>	<b>103-106</b>
<b>(M)</b>	<b>F12 Large Frame Fixed Displacement Bent-Axis Pumps/Motors</b>	<b>107-110</b>
<b>(M)</b>	<b>F1 Fixed Displacement Bent-Axis Truck Pumps/Motors</b>	<b>111-112</b>
<b>(M)</b>	<b>V12 Small Frame Variable Displacement Bent-Axis Motors</b>	<b>113-116</b>
<b>(M)</b>	<b>V14 Large Frame Variable Displacement Bent-Axis Motors</b>	<b>117-120</b>
<b>(M)</b>	<b>T12 Dual Displacement Bent-Axis Motors</b>	<b>121-124</b>
<b>(B)</b>	<b>M3/M4 High Performance Vane Motors</b>	<b>125-127</b>
<b>(B)</b>	<b>M5 High Performance Fan Drive Vane Motors</b>	<b>128-130</b>
<b>(B)</b>	<b>MR-MRE Low Speed High Torque Small Displacement Radial Piston Motors</b>	<b>131-134</b>
<b>(B)</b>	<b>MRT-MRTE-MRTF Low Speed High Torque Large Displacement Radial Piston Motors</b>	<b>131,135-137</b>
<b>(B)</b>	<b>MRD-MRDE, MRV-MRVE Low Speed High Torque Variable Displacement Radial Piston Motors</b>	<b>131,138-140</b>
<b>(B)</b>	<b>Gold Cup Open &amp; Closed Circuit Pumps &amp; Motors for Hydrostatic Transmissions</b>	<b>63-74</b>



ENGINEERING YOUR SUCCESS.

## F11 Small Frame Fixed Displacement Bent-Axis Motors



F11 is the well-proven, bent-axis, fixed displacement heavy-duty motor Series. They can be used in numerous applications on both open and closed loop circuits where high speed and extreme shaft loads are required.

### Motor Performance Data

Model Series	Displacement in <sup>3</sup> /rev (cc/rev)	Outlet Pressure PSI (BAR)	Continuous Drive Speed RPM	Flow @ Rated RPM GPM (LPM)
F11005	0.30 (4.9)	5000 (350)	12800	14 (53.0)
F11006	0.37 (6.0)	5000 (350)	10200	16 (60.6)
F11010	0.60 (9.8)	5000 (350)	10200	26 (98.4)
F11012	0.76 (12.5)	5000 (350)	9400	31 (117.3)
F11014	0.87 (14.3)	5000 (350)	9000	34 (128.7)
F11019	1.16 (19.0)	5000 (350)	8100	40 (151.4)

### Markets

### Applications

Forestry	Saw Drives, Feller Bunchers, Skidder, Forwarder, Cranes, Mowers / Cutters
Industrial	Aircraft Test Stands
Marine	Deck Cranes, Constant Tension Winches, Hatch Covers
Oil & Gas	Nitrogen Pumps, Frac Trucks, Coil Tubing
Construction	Skid Steer, Off-Highway Trucks, Fan Drives, Cranes, Dust Collector, Excavator
Mining	Drill Rigs, Top Drives, Loaders, Subsurface Loaders, Tunneling Equipment
Material Handling	Conveyor Drives, Truck Mounted Cranes, Mixers
Recycling	Shredders, Vacuum Truck Systems
Military	Fan Drives

## F11 Small Frame Fixed Displacement Bent-Axis Motors

### Performance Characteristics

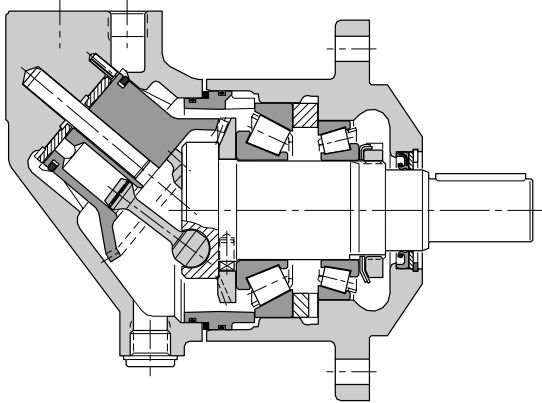

### Benefits/Features

- F11 motors can be used at unusually high shaft speeds
- Operating pressures to 6091.59 PSI (420 BAR)
- Compact, lightweight motor and pump
- Laminated piston ring provides low internal leakage and thermal shock resistance
- F11 Series have very few moving parts
- Heavy duty roller bearings

F11 Series Overall Efficiency

Motor - 250 bar (3625 PSI)

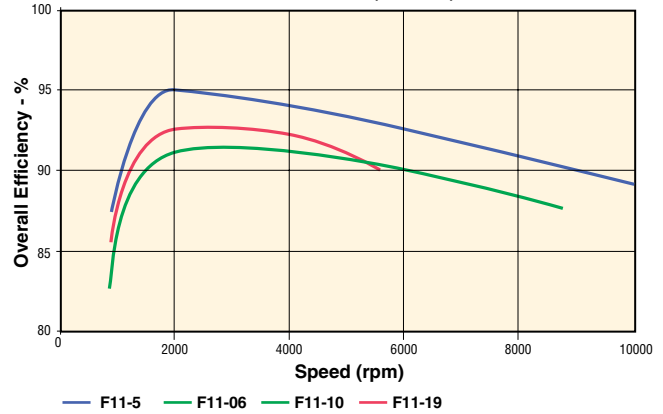

F11 Series Overall Efficiency

Motor - 250 bar (3625 PSI)

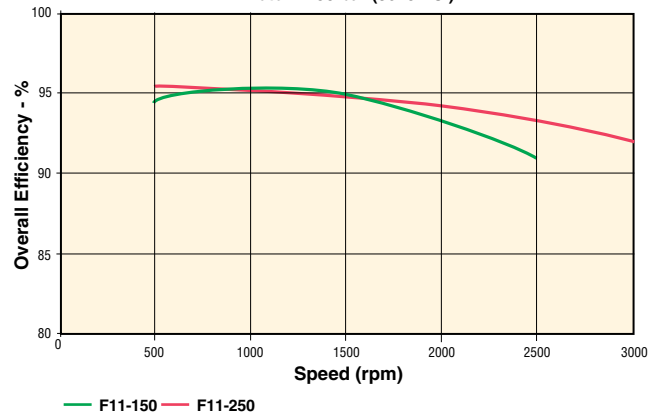

## F11 Small Frame Fixed Displacement Bent-Axis Motors

**F11-14**  
(SAE versions)

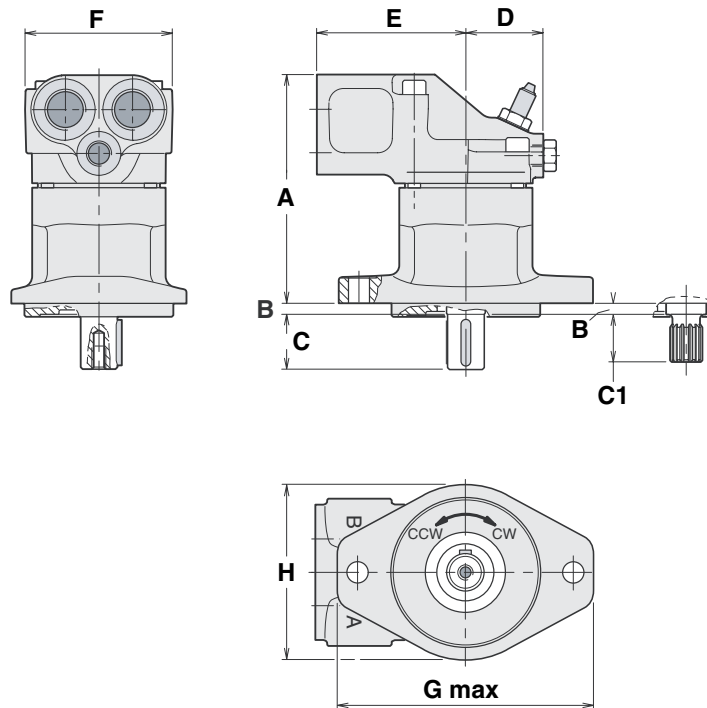

### Dimensions, inch (mm)

Series	A max	B	C	C1	D	E	F	G max	H
F11-10 F11-14	6.21 (175.7)	0.31 (7.9)	1.50 (38.1)	1.30 (33.0)	2.09 (53.1)	4.02 (102.1)	3.98 (101.1)	6.85 (174.0)	4.72 (119.9)
F11-19	7.13 (181.1)	0.31 (7.9)	1.50 (38.1)	1.30 (33.0)	2.48 (63.0)	3.46 (87.9)	4.49 (114.0)	6.93 (176.0)	4.84 (122.9)



# Motors

## F11 Model Ordering Code

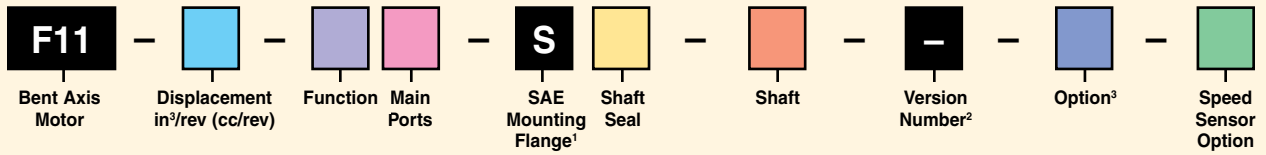

Code	Displacement in <sup>3</sup> /rev (cc/rev)
005*	0.30 in <sup>3</sup> /rev (4.9 cc/rev)
006*	0.37 in <sup>3</sup> /rev (6.0 cc/rev)
010*	0.60 in <sup>3</sup> /rev (9.8 cc/rev)
012*	0.76 in <sup>3</sup> /rev (12.5 cc/rev)
014	0.87 in <sup>3</sup> /rev (14.3 cc/rev)
019	1.16 in <sup>3</sup> /rev (19.0 cc/rev)

\* ISO or CETOP mounting options, see catalog on CD

Code	Function	005	006	010	012	014	019
M	Motor	x	x	x	—	—	x
H	Motor, High Pressure	x	—	x	x	x	x
S	Motor, High Speed	—	—	x	—	—	x

\* Internal drain

Code	Main Ports	005	006	010	012	014	019
U	SAE, UN Threads	x	x	x	x	x	x
B	BSP Threads	x	x	x	x	x	x
F	SAE 6000 psi (413.7 bar) Flange*	—	—	x	x	x	—

\* Metric female threads

\*\* UNF threads

x: Available —: Not Available

<sup>1</sup>NOTE: CETOP and ISO mounting also available. See catalog on CD.

<sup>2</sup>Assigned by factory for special versions

<sup>3</sup>None (see catalog on CD)

Code	Shaft Seal	005	006	010	012	014	019
N	NBR*, Low Pressure	x	x	x	—	—	x
V	FPM**, High Pressure, High Temperature	—	x	x	x	x	x
S	FPM**, Saw Motor	—	x	x	—	—	x

\* NBR - Nitrile rubber

\*\* FPM - Fluorocarbon rubber

Code	Shaft	005	006	010	012	014	019
T	SAE Key	—	—	—	—	x	x
S	SAE Spline	x	x	x	x	x	x
K	Metric Key	x	x	x	x	x	x
D	DIN 5480 Spline	x	x	x	x	x	x

For metric options, see catalog on CD.

Code	Option	005	006	010	012	014	019
MVR	Make-up valve clockwise	—	—	x	x	x	x
MVL	Make-up valve counter clockwise	—	—	x	x	x	x

Code	Speed Sensor	005	006	010	012	014	019
P	Prepared for Speed Sensor	—	—	—	x	x	x

Order speed sensor kit# 3785190 separately

## F12 Large Frame Fixed Displacement Bent-Axis Motors



Series F12 is the high performance bent-axis, fixed displacement heavy-duty motor series. They can be used in numerous applications at unusually high shaft speeds.

### Motor Performance Data

Model Series	Displacement in <sup>3</sup> /rev (cc/rev)	Maximum Outlet Pressure PSI (BAR)	Rated Drive Speed RPM	Flow GPM (LPM)
F12-030	1.83 (30.0)	6000 (420)	6700	44 (166.6)
F12-040	2.44 (40.0)	6000 (420)	6100	53 (200.6)
F12-060	3.64 (59.6)	6000 (420)	5300	68 (257.4)
F12-080	4.91 (80.4)	6000 (420)	4800	85 (321.8)
F12-090	5.68 (93.0)	6000 (420)	4600	—
F12-110	6.72 (110.1)	6000 (420)	4400	105 (397.5)
F12-125	7.63 (125.0)	6000 (420)	4200	—
F12-150	9.15 (150.0)	5000 (350)	3200	103 (139.9)
F12-250	14.77 (242.0)	5000 (350)	2700	154 (583.0)

### Markets

### Applications

Forestry	Saw Drives, Feller Bunchers, Skidder, Forwarder, Cranes, Mowers / Cutters
Industrial	Aircraft Test Stands
Marine	Deck Cranes, Constant Tension Winches, Hatch Covers
Oil & Gas	Nitrogen Pumpers, Frac Trucks
Construction	Skid Steer, Off-Highway Trucks, Fan Drives, Cranes, Dust Collector, Excavator
Mining	Drill Rigs, Top Drives, Loaders, Subsurface Loaders, Tunneling Equipment
Material Handling	Conveyor Drives, Truck Mounted Cranes, Mixers
Recycling	Shredders, Vacuum Truck Systems
Military	Fan Drives

## F12 Large Frame Fixed Displacement Bent-Axis Motors

### Performance Characteristics

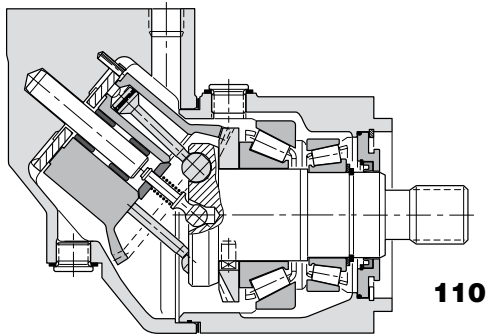
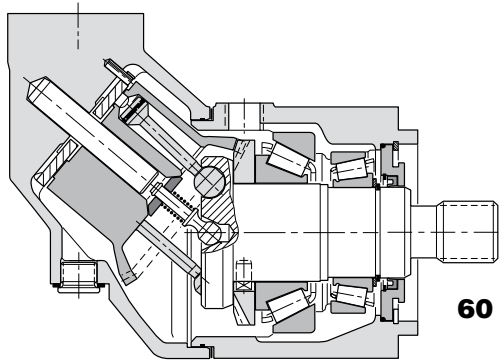

#### F12 Series Overall Efficiency

Motor - 420 bar (6092 PSI)

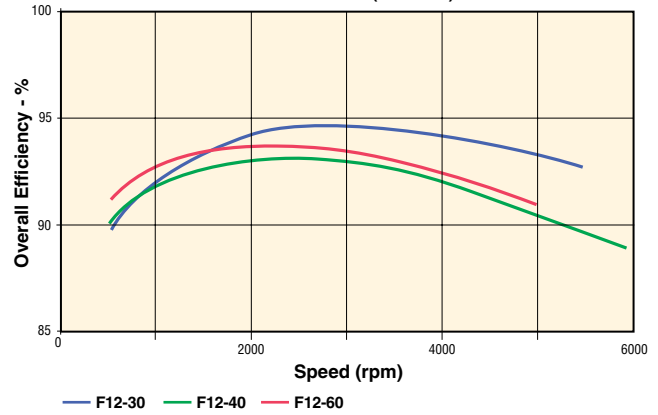

#### F12 Series Overall Efficiency

Motor - 420 bar (6092 PSI)

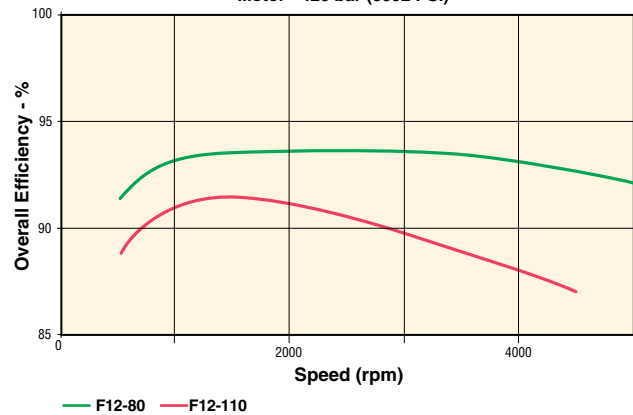

#### F12 Series Overall Efficiency

Motor - 250 bar (3625 PSI)

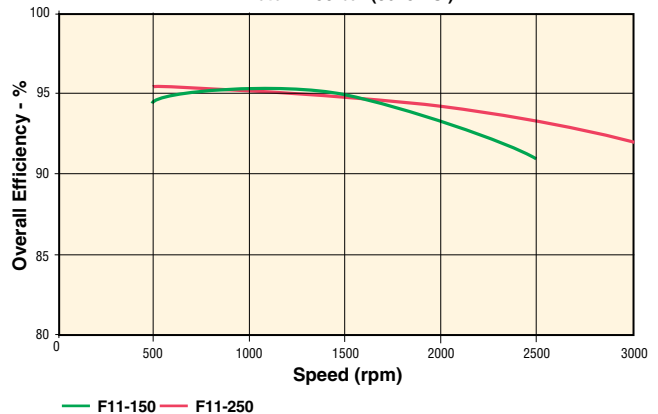

### Benefits/Features

- Operating pressures to 6961.81 PSI (480 BAR)
- Compact, lightweight motor and pump
- Laminated piston ring provides low internal leakage and thermal shock resistance
- F12 Series have very few moving parts
- Heavy duty roller bearings

## F12 Large Frame Fixed Displacement Bent-Axis Motors

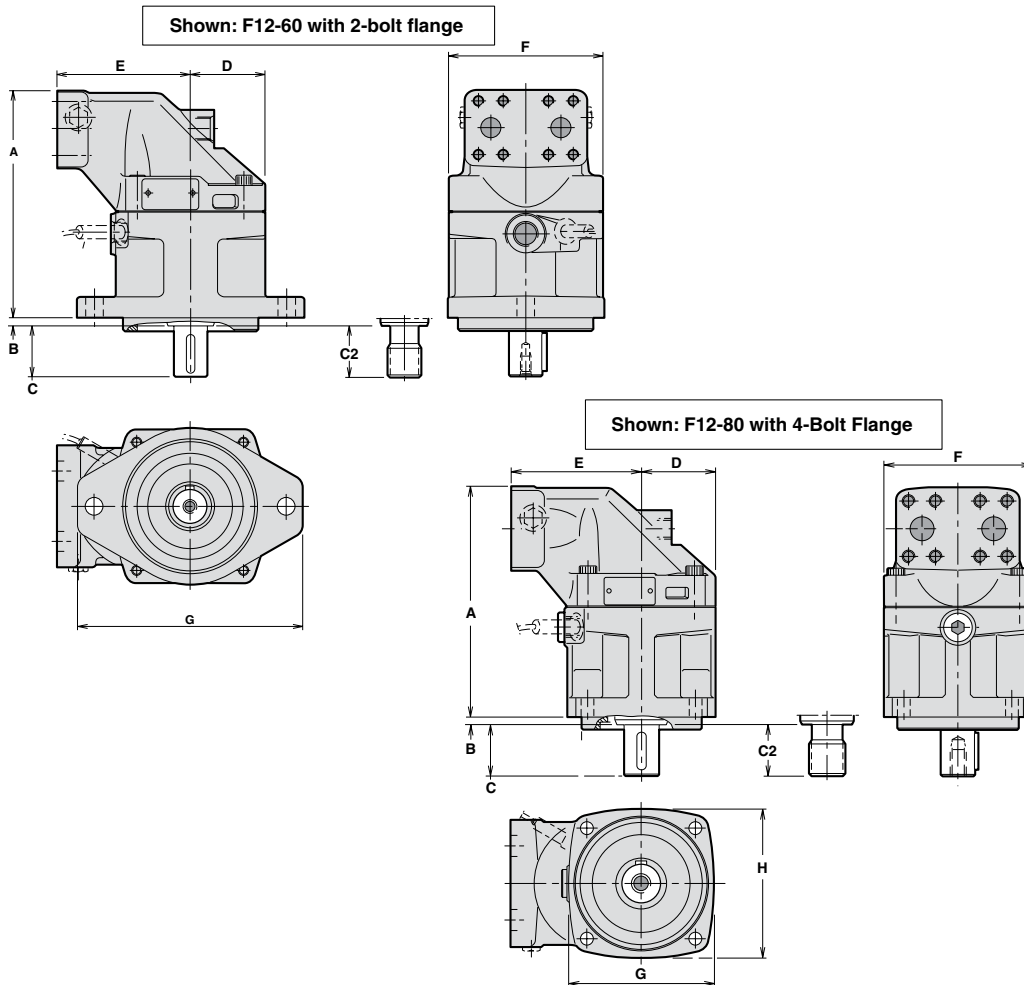

### Dimensions, inch (mm)

Series 2-BOLT	A	B	C	C2	D	E	F	G	
F12-30	7.46 (189.5)	0.31 (7.9)	1.5 (38.1)	1.3 (33.0)	2.32 (58.9)	3.94 (100.1)	4.80 (121.9)	6.93 (176.0)	
F12-40	7.76 (197.1)	0.3 (7.9)	1.89 (48.0)	1.89 (48.0)	2.56 (64.0)	4.33 (110.0)	5.28 (134.1)	8.46 (214.9)	
F12-60	8.43 (214.1)	0.31 (7.9)	1.89 (48.0)	1.89 (48.0)	2.76 (70.1)	4.92 (125.0)	5.67 (144.0)	8.46 (214.9)	
Series 4-BOLT	A	B	C	C2	D	E	F	G	H
F12-30	7.46 (189.5)	0.31 (7.9)	1.50 (38.1)	1.30 (33.0)	2.32 (58.9)	3.94 (100.1)	4.80 (121.9)	4.65 (118.1)	4.65 (118.1)
F12-40	7.76 (197.1)	0.31 (7.9)	1.89 (48.0)	1.89 (48.0)	2.56 (65.0)	4.33 (110.0)	5.28 (134.1)	5.83 (148.1)	5.67 (144.0)
F12-60	8.43 (214.1)	0.31 (7.9)	1.89 (48.0)	1.89 (48.0)	2.76 (70.1)	4.92 (125.0)	5.67 (144.0)	5.83 (148.1)	5.67 (144.0)
F12-80	9.45 (240.0)	0.31 (7.9)	2.13 (54.1)	2.13 (54.1)	3.05 (77.5)	5.31 (134.9)	6.10 (154.9)	6.10 (154.9)	6.10 (154.9)
F12-90	9.45 (240.0)	0.31 (7.9)	2.13 (54.1)	2.13 (54.1)	3.05 (77.5)	5.31 (134.9)	6.10 (154.9)	6.10 (154.9)	6.10 (154.9)
F12-110	10.39 (263.9)	0.31 (7.9)	2.64 (67.1)	2.63 (66.8)	3.35 (85.1)	5.71 (145.0)	6.69 (169.9)	8.03 (204.0)	7.87 (199.9)
F12-125	10.39 (263.9)	0.31 (7.9)	2.64 (67.1)	2.63 (66.8)	3.35 (85.1)	5.71 (145.0)	6.69 (169.9)	8.03 (204.0)	7.87 (199.9)





# Motors

## F12 Model Ordering Code

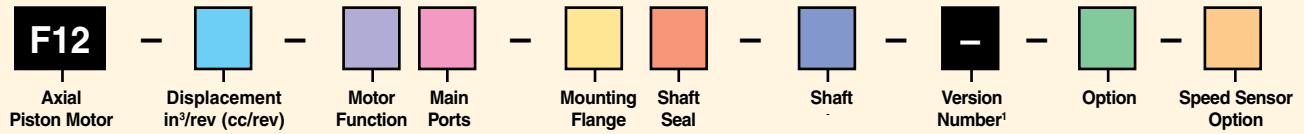

Code	Displacement in³/rev (cc/rev)
030	1.83 in³/rev (30.0 cc/rev)
040	2.44 in³/rev (40.0 cc/rev)
060	3.65 in³/rev (59.8 cc/rev)
080	4.91 in³/rev (80.4 cc/rev)
090	5.68 in³/rev (93.0 cc/rev)
110	6.72 in³/rev (110.1 cc/rev)
125	7.63 in³/rev (125.0 cc/rev)
150	9.15 in³/rev (150.0 cc/rev)
250	14.77 in³/rev (242.0 cc/rev)

Code	Motor Function	30	40	60	80	90	110	125	150	250
M	Motor	x	x	x	x	x	x	x	x	—
H	Motor-High Pressure	—	—	—	—	—	—	—	x	—
Q	Quiet	—	—	—	—	—	—	—	—	x

Code	Main Ports	30	40	60	80	90	110	125	150	250
S	SAE Flange Code 62 6000 PSI (413.7 BAR)	x	x	x	x	x	x	x	—	—
U*	SAE, UN Threads	x	x	x	x	x	x	x	—	—
F	SAE 6000 PSI Flange	—	—	—	—	—	—	—	x	x

\* Reduced pressure rating 350 bar

Code	Mounting Flange	30	40	60	80	90	110	125	150	250
S	SAE 4 bolt	x	x	x	x	x	x	x	x	x
T	SAE 2 bolt	x	x	x	—	—	—	—	—	—
X	SAE D 4 bolt	—	—	—	x	x	—	—	—	—

NOTE: ISO and cartridge mounting also available. See catalog on CD.

x: Available —: Not Available

¹Assigned by factory for special versions

²Order speed sensor kit# 3785190 separately.

Code	Shaft Seal	30	40	60	80	90	110	125	150	250
N	NBR*, Low Pressure	x	x	x	x	x	x	x	x	—
V	FPM**, High Pressure, High Temperature	x	x	x	x	x	x	x	x	x

\* NBR - Nitrile rubber

\*\* FPM - Fluorocarbon rubber

Code	Shaft	30	40	60	80	90	110	125	150	250
S	SAE Spline (std)	x	x	x	x	x	x	x	x	x
U	SAE Spline (opt.)	—	—	—	x	x	—	—	—	—
T	SAE Key (std)	x	x	x	x	x	x	x	x	—
K	Metric Key	—	—	—	—	—	—	—	x	x
F	SAE Spline	—	—	—	—	—	—	—	—	x
D	Spline, DIN 5480	—	—	—	—	—	—	—	—	x

Code	Option	30	40	60	80	90	110	125	150	250
000	Standard	x	x	x	x	x	x	x	x	x
L01	Integr. Flushing Valve	x	x	x	x	x	—*	—*	—	—
MVL	Make-up valve counter clockwise rotation	x	—	—	—	—	—	—	—	—
MVR	Make-up valve clockwise rotation	x	—	—	—	—	—	—	—	—

\* F12-110 accessory valve block. See page 36 of catalog on CD.

Code	Speed Sensor Option	30	40	60	80	90	110	125	150	250
0	Standard	x	x	x	x	x	x	x	x	x
P	Prepared for Speed Sensor	x	x	x	x	x	x	x	—	—

## F1 Fixed Displacement Bent-Axis Truck Motors



F1 Motors are used on applications that do not require high shaft sideloading. Their light weight, compact size and efficient design make them the first choice on many mobile applications including winches, augers and spreaders.

### Motor Performance Data

Model Series	Displacement in <sup>3</sup> /rev (cc/rev)	Maximum Cont. Pressure PSI (BAR)	Rated Drive Speed RPM	Max. Theoretical Torque in-lb (m-kg)	Maximum Output Power @ Rated Speed HP (KW)
F1-25-M	1.56 (25.6)	3600 (250)	2300	719 (82.8)	27 (20.1)
F1-41-M	2.50 (40.9)	3600 (250)	2000	1154 (133.0)	36 (26.8)
F1-51-M	3.12 (51.1)	3600 (250)	1800	1439 (165.8)	41 (30.6)
F1-61-M	3.63 (59.5)	3600 (250)	1700	1678 (193.2 g)	45 (33.6)
F1-81-M	4.98 (81.6)	3600 (250)	1500	2300 (265.0)	55 (41.0)
F1-101-M	6.28 (102.9)	3600 (250)	1400	2904 (334.6)	64 (47.7)

### Markets

### Applications

Forestry	Knuckle Boom Loader, Cranes, Mowers / Cutters
Construction	Off-Highway Trucks, Fan Drives
Mining	Dump Trucks
Material Handling	Truck Mounted Cranes, Lift Trucks
Recycling	Vaccum Truck Systems, Refuse Trucks - ASL, Rear Loaders
Military	Fan Drives

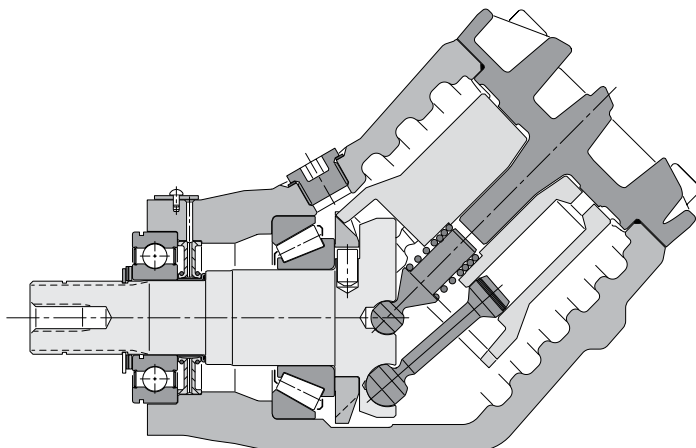

### Benefits/Features

- Higher self-priming speeds
- Operating pressures to 5801.51 PSI (400 BAR)
- New frame sizes to meet market requirements
- Higher overall efficiency
- Increased reliability
- Reduced noise level
- Smaller installation dimensions

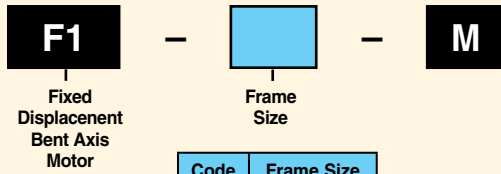

Code	Frame Size
25	1.56 in <sup>3</sup> /rev (25.6 cc/rev)
41	2.50 in <sup>3</sup> /rev (40.9 cc/rev)
51	3.12 in <sup>3</sup> /rev (51.1 cc/rev)
61	3.66 in <sup>3</sup> /rev (59.5 cc/rev)
81	4.98 in <sup>3</sup> /rev (81.6 cc/rev)
101	6.28 in <sup>3</sup> /rev (102.9 cc/rev)

**NOTES:**

1. Pressure port on 25, 41, 51 and 61 sizes is 3/4". Pressure port on 81 and 101 sizes is 1".
2. Suction fitting must be ordered separately.
3. Use seven digit number when placing order.

Ordering Code	Ordering No.
F1-25-M	378 1724
F1-41-M	378 1740
F1-51-M	378 1750
F1-61-M	378 1760
F1-81-M	378 1780
F1-101-M	378-1800

## F1 Fixed Displacement Bent-Axis Truck Pumps/Motors

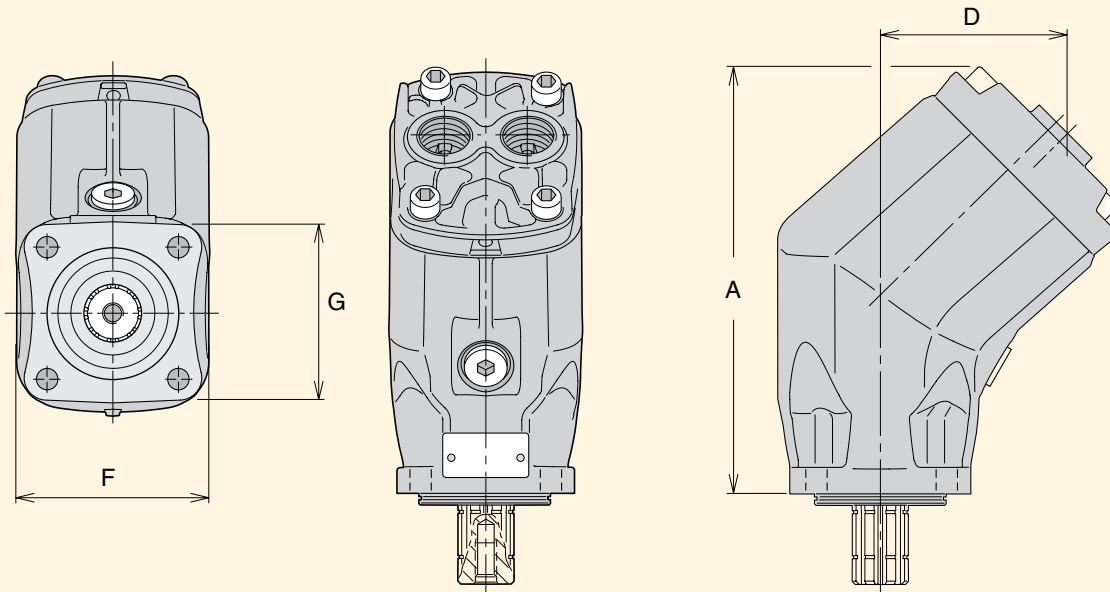

### Dimensions, inch (mm)

Series	A	B	C	D	E	F	G
F1-25 F1-41 F1-51 F1-61	8.07 (205)	0.27 (7)	2.17 (55)	5.10 (129.5)	2.22 (56.5)	4.25 (108)	4.29 (109)
F1-81 F1-101	10.20 (259)	0.27 (7)	2.17 (55)	5.67 (144)	2.48 (63)	4.65 (118)	4.33 (110)

## V12 Small Frame Variable Displacement Bent-Axis Motors



Series V12 is a bent-axis, variable displacement motor. It is intended for both open and closed circuits, mainly in mobile applications, but the V12 can also be utilized in a wide variety of other applications.

### Motor Performance Data

Model Series	Displacement	Outlet Pressure	Drive Speed	Flow @ Rated RPM
V12-60	3.66 (60)	6000 (420)	5600	57 (215.8)
V12-80	4.88 (80)	6000 (420)	5000	66 (249.8)

### Markets

### Applications

Forestry	Feller Bunchers, Skidder, Forwarder, Cranes
Marine	Deck Cranes, Constant Tension Winches
Construction	Wheel Loader, Cranes, Excavator
Mining	Drill Rigs, Top Drives, Loaders, Subsurface Loaders, Tunneling Equipment
Power Gen	Turbine Start
Material handling	Conveyor Drives, Truck Mounted Cranes, Mixers
Recycling	Shredders
Military	Fan Drives

## V12 Small Frame Variable Displacement Bent-Axis Motors

### Performance Characteristics

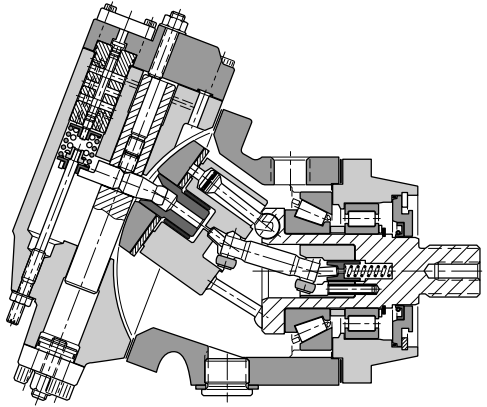

### Benefits/Features

- Tolerates very high speeds due to low weight pistons with laminated piston rings and a compact design of the rotating parts
- High output power; the overall efficiency remains high throughout the entire displacement range
- The 9-piston design provides high start-up torque and smooth motor operation
- Wide displacement ratio (5:1)
- Broad range of controls and accessory valves for most applications
- Small envelope size and a high power-to-weight ratio
- ISO, cartridge and SAE versions
- Low noise levels due to a very compact and sturdy design with smooth fluid passages
- Positive piston locking, strong synchronizing shaft, heavy-duty bearings and small number of parts add up to a compact and robust motor with long service life and proven reliability.

### V12-60 Series Overall Efficiency

Motor - 420 bar (6092 PSI)

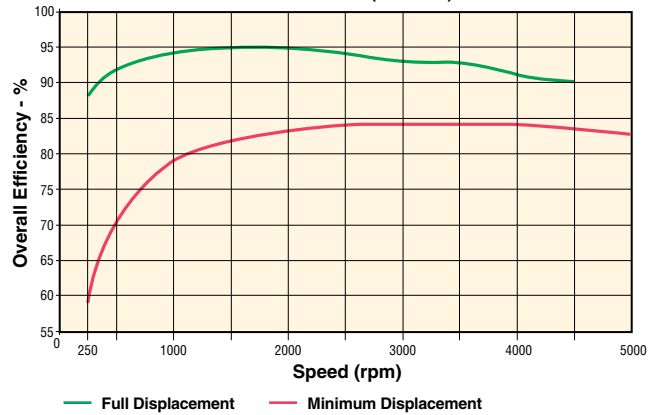

### V12-80 Series Overall Efficiency

Motor - 420 bar (6092 PSI)

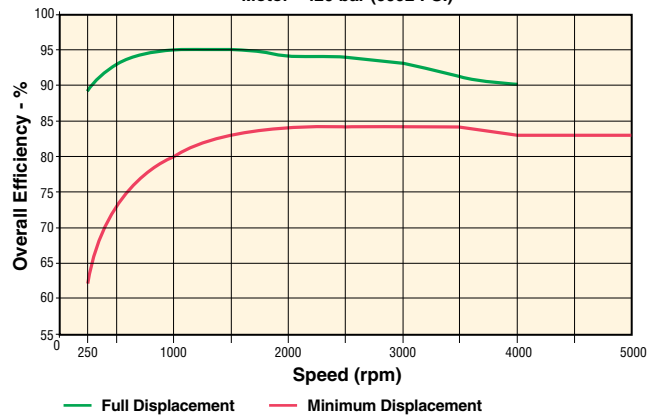

## V12 Small Frame Variable Displacement Bent-Axis Motors

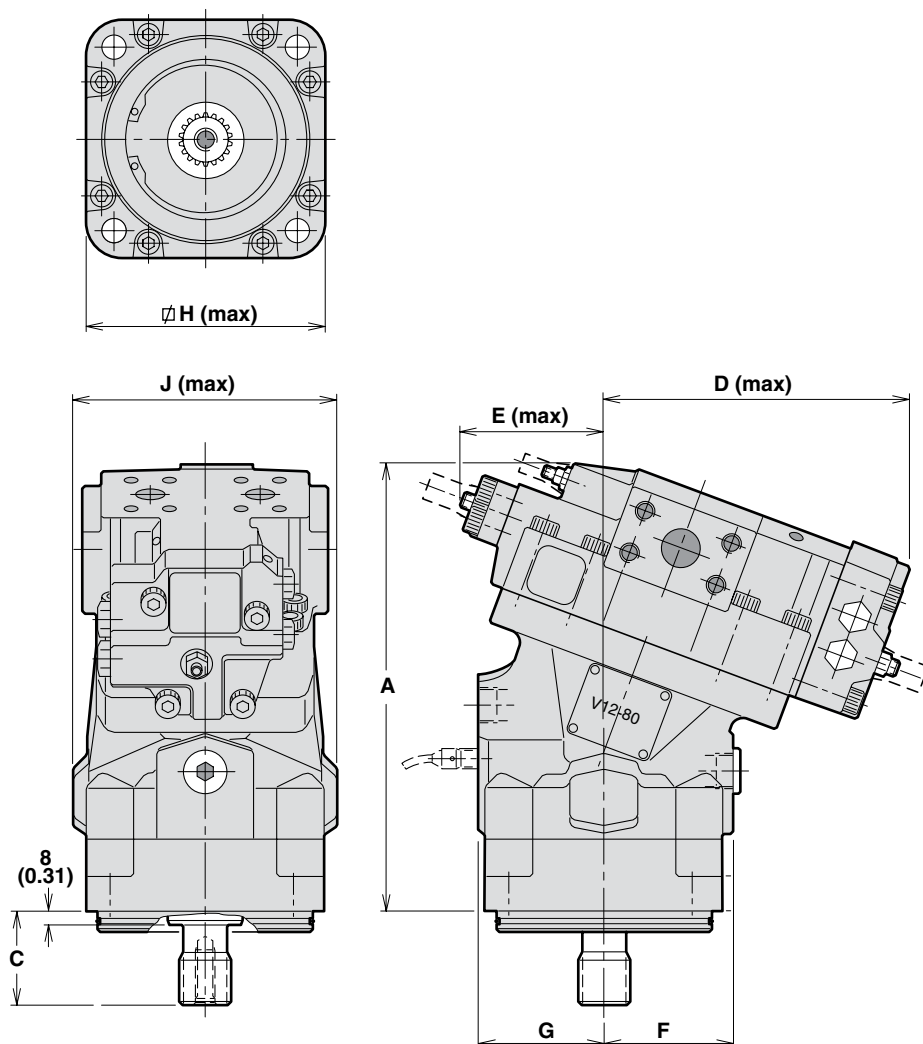

### Dimensions, inch (mm)

Series	A	C max	D max	E max	F	G	H max	J max
V12-60	10.51 (267)	2.19 (55.6)	7.40 (188)	3.43 (87)	3.03 (77)	2.99 (76)	5.87 (149)	6.26 (159)
V12-80	11.02 (280)	2.19 (55.6)	7.60 (193)	3.54 (90)	3.15 (80)	3.07 (78)	5.87 (149)	6.50 (165)



# Motors

## V12 Model Ordering Code

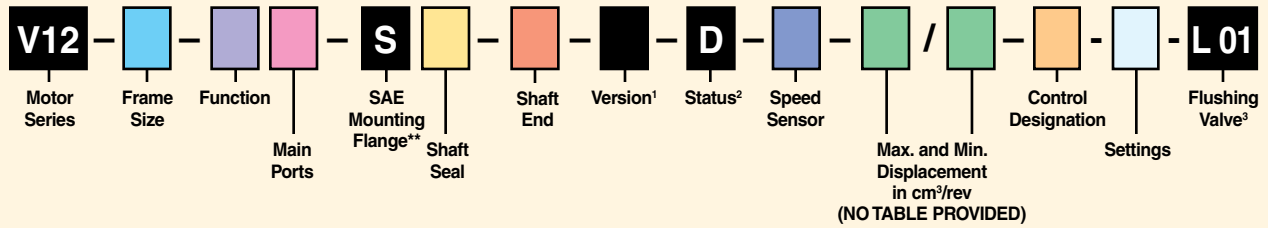

Code	Frame Size
60	3.66 in³/rev (60 cm³/rev)
80	4.88 in³/rev (80 cm³/rev)

Code	Function
M	Motor; normal end cap position (EO, EP, HO & HP only)
T	Motor; normal end cap position (AC & AH only)

Code	Main Ports*
S	SAE Flange; UN Threads, Side Ports
U	SAE Flange; UN Threads, Rear Ports

Code	Shaft Seal	60	80
H	NBR (Nitrile)	x	x
V	FPM (High Temperature Fluorocarbon)	(x)	(x)

Code	Shaft End***	60	80
S	Spline (SAE J498b)	(x)	(x)

Code	Speed Sensor
0	No Sensor
S	Speed Sensor (not installed)
P	Prepared for Speed Sensor

Code	Control	60	80
AC I 01 I	Pressure Compensator, internal pilot pressure, internal servo supply	x	x
AC E 01 I	Pressure Compensator, external pilot pressure, internal servo supply	(x)	(x)
AH I 01 I	Pressure Compensator, hydraulic override internal pilot pressure, internal servo supply	x	x
AH E 01 I	Pressure compensator, hydraulic override, external pilot pressure, internal servo supply	(x)	(x)
EOL 01 I	Electrohydraulic, two-position, 12 VDC, internal servo supply	x	x
EOL 01 E	Electrohydraulic, two-position, 12 VDC, external servo supply	(x)	(x)
EOH 01 I	Electrohydraulic, two-position, 24 VDC, internal servo supply	x	x
EPL 01 I	Electrohydraulic, proportional, 12 VDC, internal servo supply	x	x
EPL 01 E	Electrohydraulic, proportional, 12 VDC, external servo supply	(x)	(x)
EPH 01 I	Electrohydraulic, proportional, 24 VDC, internal servo supply	x	x
EPH 01 E	Electrohydraulic, proportional, 24 VDC, external servo supply	(x)	(x)
HOS 01 I	Hydraulic, two-position, standard version, internal servo supply	x	x
HOS 01 E	Hydraulic, two-position, standard version, external servo supply	(x)	(x)
HPS 01 I	Hydraulic, proportional, standard version, internal servo supply	x	x
HPS 01 E	Hydraulic, proportional, standard version, external servo supply	(x)	(x)

Settings
<b>AC, AH:</b> Threshold Pressure: <b>2175.57, 2900.76, or 3625.94</b> PSI ( <b>150, 200 or 250</b> bar) Modulating Pressure: <b>217.56, 362.59, 725.19</b> PSI ( <b>015, 025 or 050</b> bar)
<b>EO, EP:</b> Threshold Current: <b>400</b> mA (12 VDC), <b>200</b> mA (24 VDC) Modulating Current: <b>000</b> (EO), <b>600</b> mA (EP 12 VDC), <b>300</b> mA (EP 24 VDC)
<b>HO, HP:</b> Threshold Pressure: <b>145.14</b> PSI ( <b>010</b> bar) Modulating Pressure: <b>000</b> (HO), <b>217.56 or 362.59</b> PSI (HP) <b>(000</b> (HO), <b>015 or 025</b> bar (HP))

x = standard; (x) = option

\* Main ports also available with metric threads. See CD.

\*\* Cartridge and ISO options available. See CD.

\*\*\* DIN shaft ends also available. See CD.

¹ Factory issued for special versions

² Control pressure setting; max and min displacement screws sealed

³ Integrated flushing valve with standard nozzle. See CD for options.

## V14 Large Frame Variable Displacement Bent-Axis Motors



Series V14 is a new generation of variable displacement, bent-axis motors, a further development of our well known V12 motor. It is designed for both open and closed circuit transmissions with focus on high performance machines.

### Motor Performance Data

Model Series	Displacement in <sup>3</sup> /rev (cc/rev)	Outlet Pressure PSI (BAR)	Drive Speed RPM	Flow GPM (LPM)
V14-110	6.71 (110)	6000 (420)	5700	99 (374.8)
V14-160	9.76 (160)	6000 (420)	5000	127 (480.8)

### Markets

### Applications

Markets	Applications
Forestry	Feller Bunchers, Skidder, Forwarder, Cranes
Marine	Deck Cranes, Constant Tension Winches
Construction	Wheel Loader, Cranes, Excavator
Mining	Drill Rigs, Top Drives, Loaders, Subsurface Loaders, Tunneling Equipment
Power Gen	Turbine Start
Material handling	Conveyor Drives, Truck Mounted Cranes, Mixers
Recycling	Shredders
Military	Fan Drives



## V14 Large Frame Variable Displacement Bent-Axis Motors

### Performance Characteristics

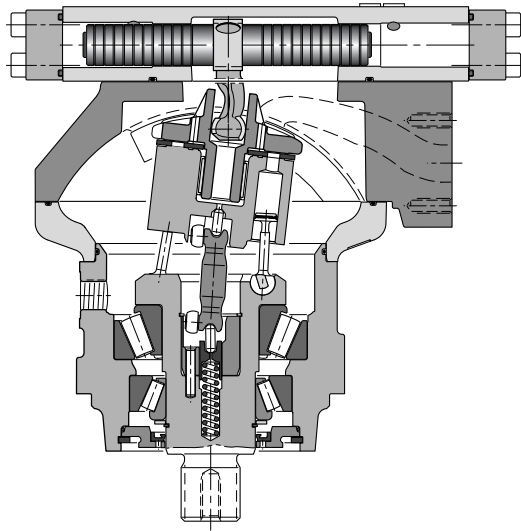

### Applications

- Excavators
- Forestry machines
- Mining and drilling machines
- Wheel loaders
- Winch drives

### Optional equipment

- Integrated sensors for speed and displacement
- Integrated flushing and pressure relief valves

### Additional benefits

- Improved speed capability
- Improved control performance
- Reduced number of parts
- Stronger shaft bearing support.

### V14-110 Series Overall Efficiency

Motor - 420 bar (6092 PSI)

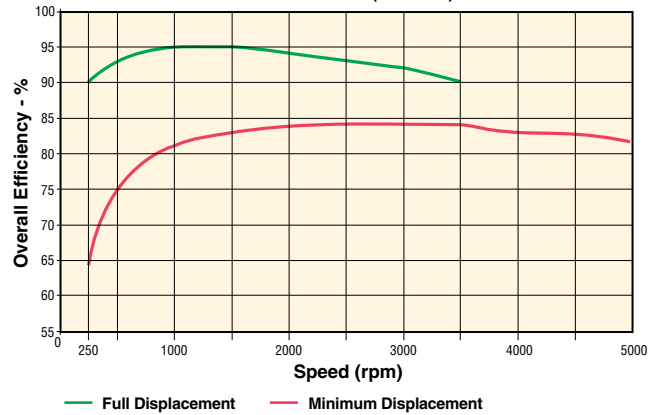

### V14-160 Series Overall Efficiency

Motor - 420 bar (6092 PSI)

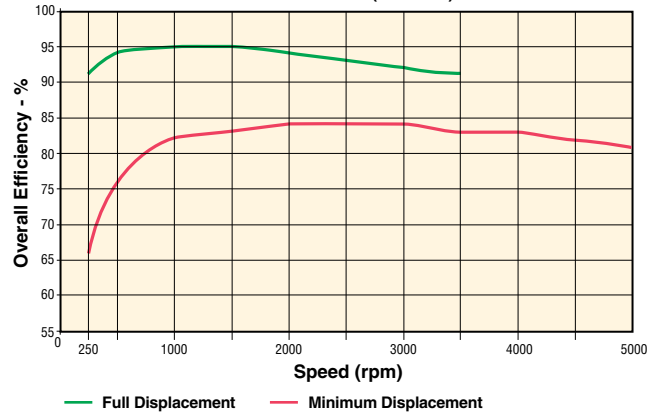

V14 Large Frame Variable Displacement Bent-Axis Motors

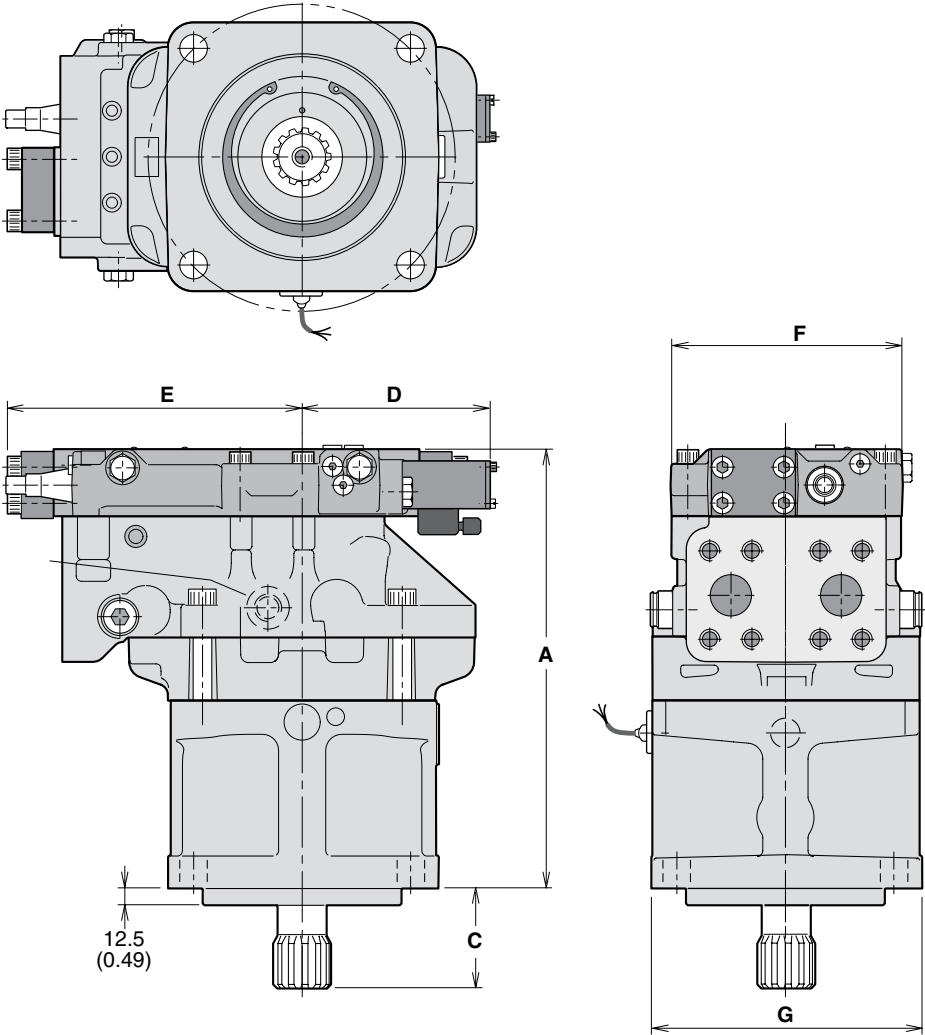

Dimensions, inch (mm)

Series	A	C	D	E	F	G
V14-110	11.54 (293)	2.93 (74.5)	5.91 (150)	8.19 (208)	6.85 (174)	8.03 (204)
V14-160	12.91 (328)	2.95 (75)	5.47 (139)	8.62 (219)	6.85 (174)	7.87 (200)



# Motors

## V14 Model Ordering Code

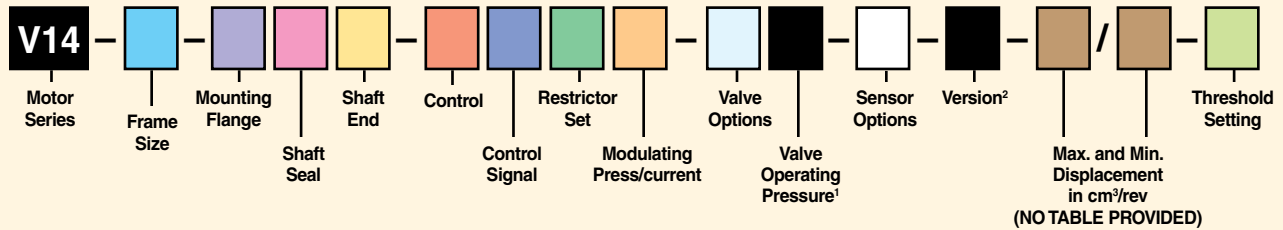

Code	Frame Size
110	6.71 in <sup>3</sup> /rev (110 cm <sup>3</sup> /rev)
160	9.76 in <sup>3</sup> /rev (160 cm <sup>3</sup> /rev)

Code	Mounting Flange
S	SAE version
I	ISO version
C*	Cartridge version

\* 110 only

Code	Shaft Seal
H	NBR (Nitrile)
V	FPM (High Temperature Fluorocarbon)

Code	Shaft End
S	SAE (SAE Version)
C	DIN (ISO Version)
D	DIN (ISO Version)

Code	Control
AC	Pressure Compensator
AD	Press. Compensator with electrohydraulic override and brake defeat valve
AH	Pressure Compensator with hydraulic override
EO	Electrohydraulic, two-position
EP	Electrohydraulic, proportional
HO	Hydraulic, two-position
HP	Hydraulic, proportional

Code	Control Signal
E	External Pressure (HO, HP)
I	Internal Pressure (AC, AD, AH)
H	24 VDC (EO, EP)
L	12 VDC (EO, EP)

Code	Control Restrictor Set (orifice dia. in mm)
1	0.7
2	0.8
3	1.0 (standard)
4	1.2

Code	Control Modulating Pressure/Current
N	AC: 0 bar EP: Non-selectable current
A	217.56 PSI (15 bar) (AC, HP)
B	362.59 PSI (25 bar) (AC, HP)
C	725.19 PSI (50 bar) (AC)

Code	Valve Options
N	None
L	Flushing Valve
P	Pressure Relief Valve

Code	Sensor Options
N	None
C	Prepared for Setting Piston Position and Shaft Speed Sensors (EP, HP)
D	Setting Piston Position and Shaft Speed Sensors (EP, HP)
L	Setting Piston Position Sensor (EP, HP)
P	Prepared for Speed Sensor
S	Speed Sensor
T	Prepared for Setting Piston Position Sensor

Code	Threshold Setting
***	Select pressure between 1450.38-5076.32 PSI (100-350 bar) (AC, AD, AH only)
400	400 mA - 12 VDC (EO, EP only)
200	200 mA - 24 VDC (EO, EP only)
10	145.14 PSI (10 bar) (HO, HP only)

<sup>1</sup> Pressure Relief Valve opening pressure (bar)

Alternately: Flushing Valve restrictor

<sup>2</sup> Factory issued for special versions

## T12 Dual Displacement Bent-Axis Motors



The T12 two-displacement motor is tailor-made for track drives. It allows a high ratio between high and low speed and installs as easily as a fixed displacement motor. Max speed ratio is 3.33-to-1. The T12 is a cartridge motor based on the well proven V12 series. The specially designed end cap with dual side ports permits a very short installation. A simple setting device moves the cylinder barrel to the maximum or

minimum displacement position. The setting is controlled by an external hydraulic pilot signal. A brake valve can be fitted without increasing the axial length of the motor. The twin ports have the same mounting pattern as those of the F12 and V12 motors. The F12/V12 accessory valve program also fits the T12 motor. As an option, integrated pressure relief valves can be included.

### Motor Performance Data

Model Series	Displacement in <sup>3</sup> /rev (cc/rev)	Outlet Pressure PSI (BAR)	Drive Speed RPM	Flow @ Rated RPM GPM (LPM)
T12-60	3.66 (60)	6000 (420)	5600	57 (215.8)
T12-80	4.88 (80)	6000 (420)	5000	66 (249.8)

### Markets

### Applications

Forestry	Feller Bunchers, Skidder, Forwarder
Construction	Dozers, Excavator

## T12 Dual Displacement Bent-Axis Motors

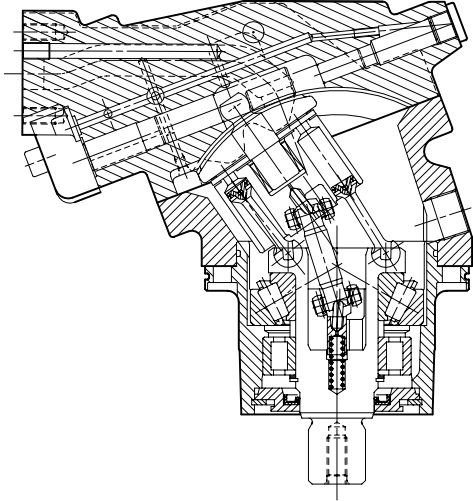

### Benefits/Features

- Designed for Track drive applications the 3.33 to 1 speed ratio provides versatility
- Cartridge mount allows very short installation dimension
- Optional valve blocks do not add to length F12/V12 accessory valves will fit T12 motor

## T12 Dual Displacement Bent-Axis Motors

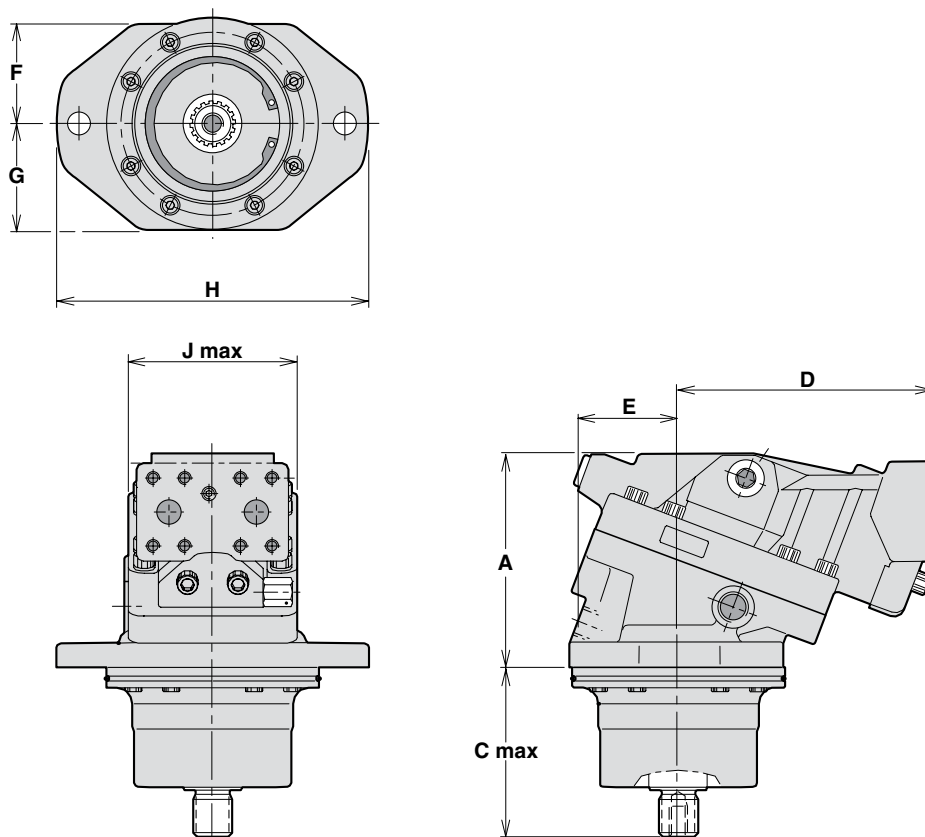

### Dimensions, inch (mm)

Series	A	C max	D	E	F	G	ØH	J max
T12-60	6.46 (164)	5.20 (132)	7.52 (191)	–	3.09 (78.5)	3.29 (83.5)	9.09 (231)	5.00 (127)
T12-80	6.30 (160)	6.12 (155.5)	8.07 (205)	3.07 (78)	3.52 (89.5)	3.92 (99.5)	10.35 (263)	5.35 (136)



# Motors

## T12 Model Ordering Code

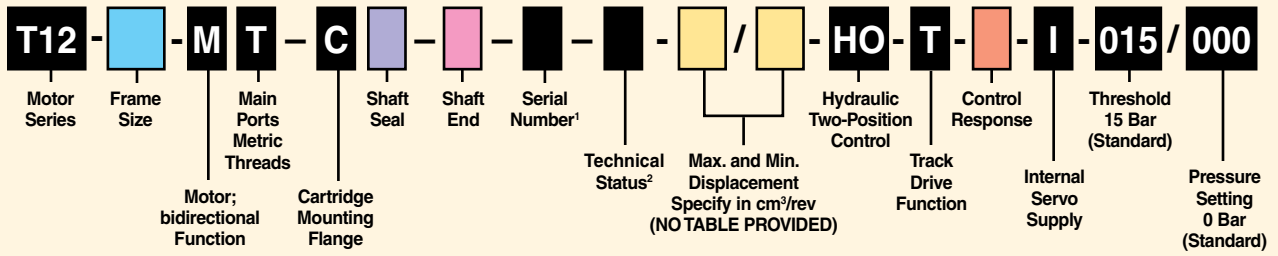

Code	Frame Size
060	3.66 in³/rev (60 cm³/rev)
080	4.88 in³/rev (80 cm³/rev)

Code	Shaft Seal
H	NBR (Nitrile)
V	FPM (High Temperature Fluorocarbon)

Code	Shaft End
C	Spline DIN 5480 (Std)
D	Spline DIN 5480

Code	Control Response
01	Fast (Standard)
02	Slow (Optional)

<sup>1</sup> Assigned for special versions

<sup>2</sup> Assigned by factory

## M3/M4 High Performance Vane Motors



The M3 and M4 Series vane motors are fixed displacement and designed especially for severe duty applications. The balance vane cartridge concept provides high volumetric efficiency, longer life, lower noise, and a high starting torque efficiency. The double motor is ideal for applications to obtain three-speed operation.

### Motor Performance Data

Single Pump Model Series	Displacement in <sup>3</sup> /rev (cc/rev)	Max. Outlet Pressure* PSI (BAR)	Rated Drive Speed* RPM	Torque (in-lb/PSI)
M3B	0.56 - 2.26 (9.2 - 37.1)	3000 (210)	4000	0.08 - 0.38
M4C	1.49 - 4.89 (24.4 - 80.1)	2500 (175)	4000	0.24 - 0.78
M4SC	1.49 - 4.89 (24.4 - 80.1)	3400 (235)	4000	0.24 - 0.78
M4D	3.97 - 8.81 (65.1 - 144.4)	2500 (175)	4000	0.63 - 1.40
M4SD	3.97 - 8.81 (65.1 - 144.4)	3400 (235)	4000	0.63 - 1.40
M4E	9.69 - 13.55 (158.8 - 222)	2500 (175)	3600	1.54 - 2.16
M4SE	9.69 - 13.55 (158.8 - 222)	2800 (190)	3600	1.54 - 2.16

Double Pump Model Series	Displacement in <sup>3</sup> /rev (cc/rev)	Max. Outlet Pressure* PSI (BAR)	Rated Drive Speed* RPM	Torque @2000 RPM and 2500 PSI
M4DC	5.46 - 13.70 (89.5 - 224.5)	2500 (175)	4000	0.87 - 2.18
M4SDC	5.46 - 13.70 (89.5 - 224.5)	3400 (235)	4000	0.87 - 2.18

\* Intermittent conditions are to be less than 10% of each minute.

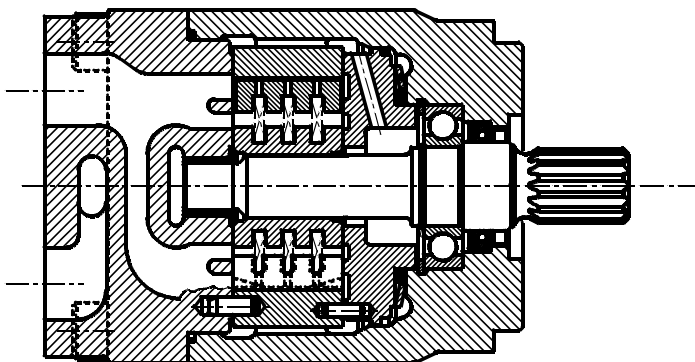

### Benefits/Features

- Low ripple torque
- Low starting torque
- Low noise
- Bi-rotational technology
- Various pilot, threaded port and porting configurations
- External/internal drain option
- Many displacement combinations for double motor



## M3/M4 High Performance Vane Motors

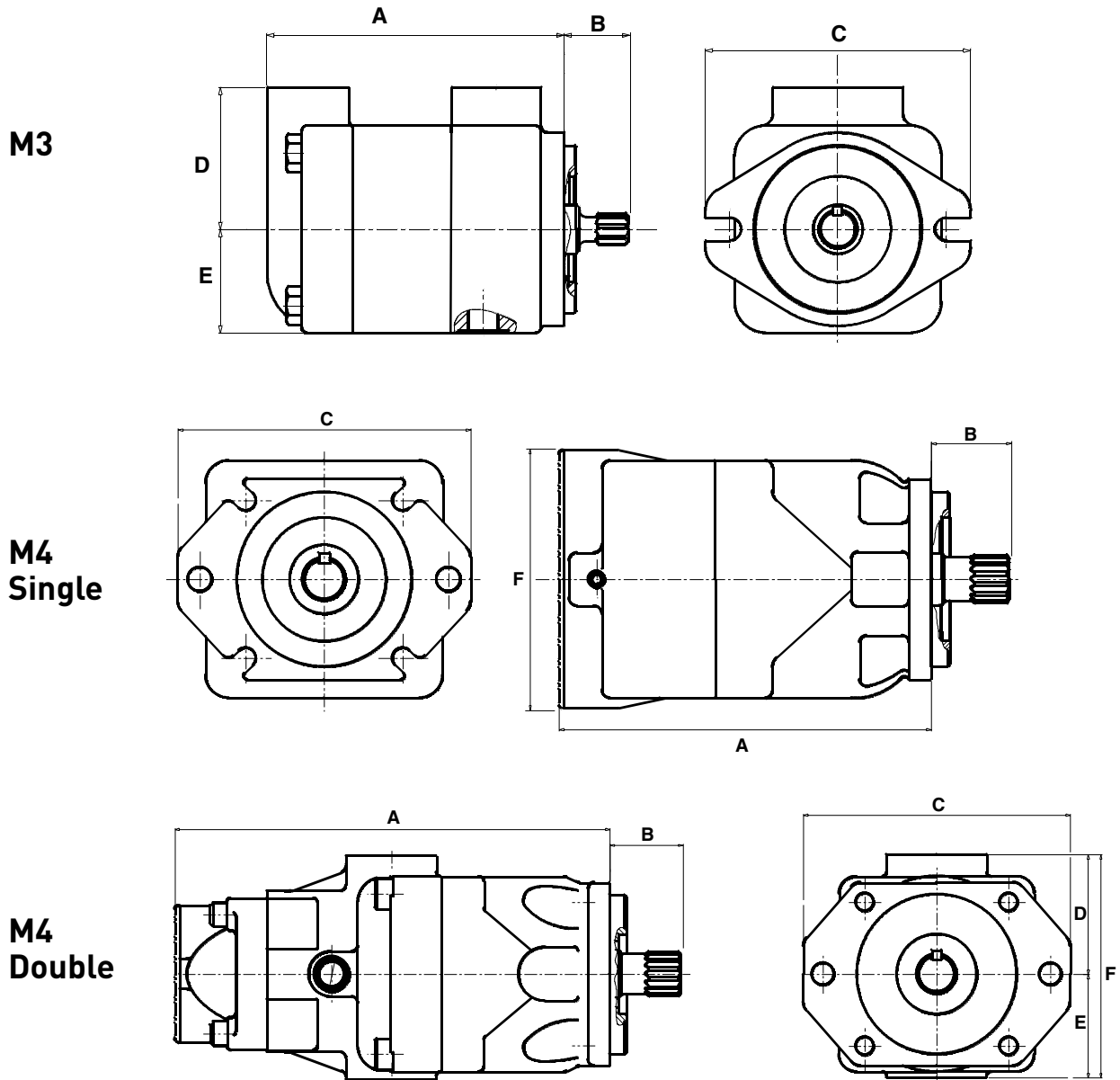

### Dimensions, inch (mm)

Series	A	B	C	D	E	F	Weight, lb (kg)
M3B	5.74 (145.8)	2.19 (55.6)	5.12 (130.0)	—	—	4.75 (120.7)	17.6 (8.0)
M4C	7.23 (183.6)	2.81 (71.4)	6.93 (176.0)	—	—	4.75 (120.7)	34.0 (15.5)
M4D	8.01 (203.5)	2.19 (55.6)	8.36 (212.3)	—	—	—	59.5 (27.0)
M4E	10.66 (270.8)	3.31 (84.1)	8.38 (212.9)	—	—	—	99.0 (45.0)
M4DC	13.63 (346.2)	2.19 (55.6)	8.36 (212.3)	3.75 (95.3)	3.25 (82.6)	7.0 (177.8)	88.0 (40.0)

# Motors

## M3/M4 Model Ordering Code

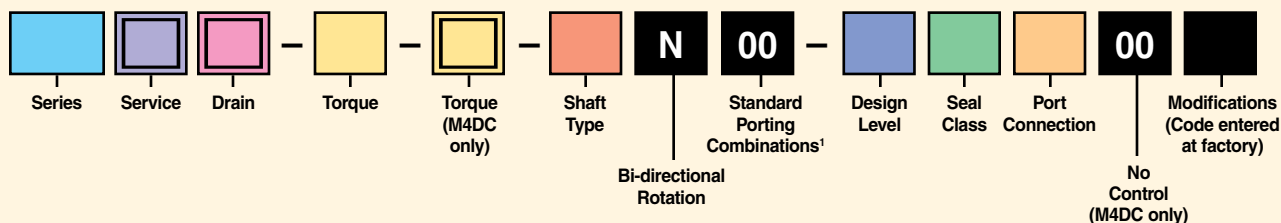

Series	
M3B	
M4C	
M4D	
M4E	
M4DC	

Code	Service
Omit	Standard
S*	Severe Duty

\* Not available on M3B

Code	Drain
Omit	External
1	Internal

Series	Torque Codes (See Table Below)		
	Single Pumps	Double Pumps A1 - B1	Double Pump A2 - B2
M3B	Use M3B Codes		
M4C	Use M4C Codes		
M4D	Use M4D Codes		
M4E	Use M4E Codes		
M4DC		Use M4D Codes	Use M4C Codes

Code	Shaft Type			
	3B	4C/4CS	4D/4DS, 4DC	4E/4ES
1	Keyed (non SAE)	Keyed SAE B	Keyed SAE C	Keyed SAE C
2		Keyed (non SAE)		
3	Splined SAE A	Splined SAE B	Splined SAE C	Splined SAE C
4	Splined SAE B			

### Torques

M3B Codes	Torque, in-lb/PSI	M4C Codes	Torque, in-lb/PSI	M4D Codes	Torque, in-lb/PSI	M4E Codes	Torque, in-lb/PSI
009	0.08	024	0.24	062	0.63	153	1.54
012	0.11	027	0.28	074	0.75	185	1.86
018	0.19	031	0.33	088	0.88	214	2.16
027	0.30	043	0.45	102	0.96		
036	0.38	055	0.57	113	1.13		
		067	0.69	128	1.28		
		075	0.78	138	1.40		

= Omit if not required  
 = Not Available

Code	Design Level
A	M4C only
B	M3B, M4D, M4E, M4DC

Code	Seal Class
1*	S1 Buna N
4**	S4 EPDM
5 †	S5 Fluorocarbon

\* Not available on M4E.

\*\* Available on M3B only.

† Must be ordered for severe duty motors.

Code	Port Connection	
	M3B	M4C/M4D/M4E M4DC
00	SAE Threaded Port SAE Drain	
01	SAE 4 Bolt Flange BSPP Drain	SAE Threaded Port SAE Drain
02	BSPP Threaded Port BSPP Drain	SAE 4 Bolt Flange UNC Threaded SAE Drain
04		SAE 4 Bolt Flange UNC Threaded BSPP Drain
M4*		SAE 4-Bolt Flange Metric Thread BSPP Drain

\* Not available on M4DC.

<sup>1</sup> Other combinations available. See catalog on CD.

## M5 High Performance Fan Drive Vane Motors



Keep the M5 fixed displacement vane motors in mind when your application requires radial and/or axial shaft loads. The fan-drive version comes equipped with a rugged double row bearing that can eliminate the need for external supports. An integrated proportional valve option

provides speed control for fan circuits. Both fan-drive and standard versions use the same high performance cartridge, giving repeatable speed at specified flows.

### Motor Performance Data

Single Pump Model Series	Displacement in <sup>3</sup> /rev (cc/rev)	Max. Outlet Pressure* PSI (BAR)	Rated Drive Speed* RPM	Torque (in-lb/PSI)
M5AF	0.38 - 1.53 (6.3 - 25)	4350 (300)	6000	0.060 - 0.242
M5B/S	0.73 - 2.75 (12 - 45)	4600 (320)	6000	0.116 - 0.437
M5BF	0.73 - 2.75 (12 - 45)	4600 (320)	6000	0.116 - 0.437

### Markets

Construction Fan Drives

### Applications

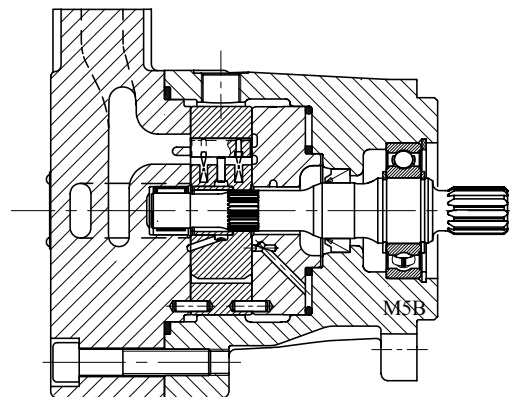
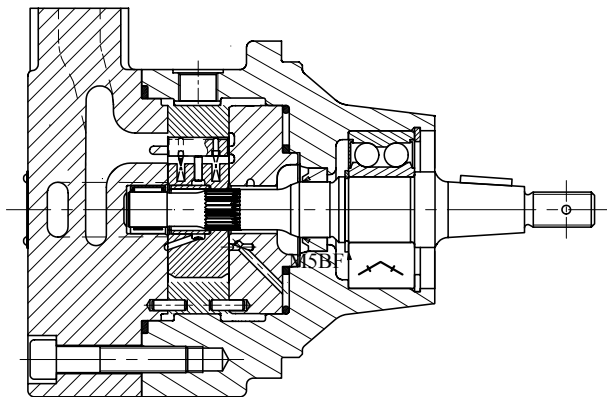

### Benefits/Features

- Low noise
- Designed for severe duty applications
- High efficiency
- High starting torque
- Low torque ripple
- Long life
- Interchangeable rotating groups
- Cross port check valve on M5BF/1

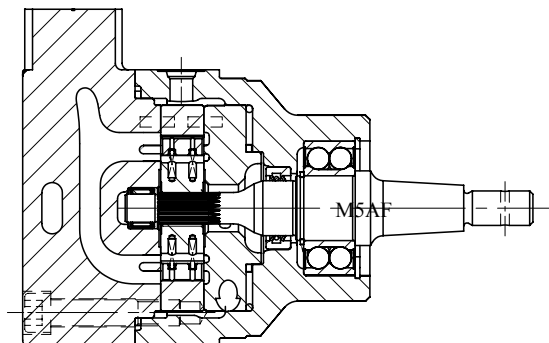

M5 High Performance Fan Drive Vane Motors

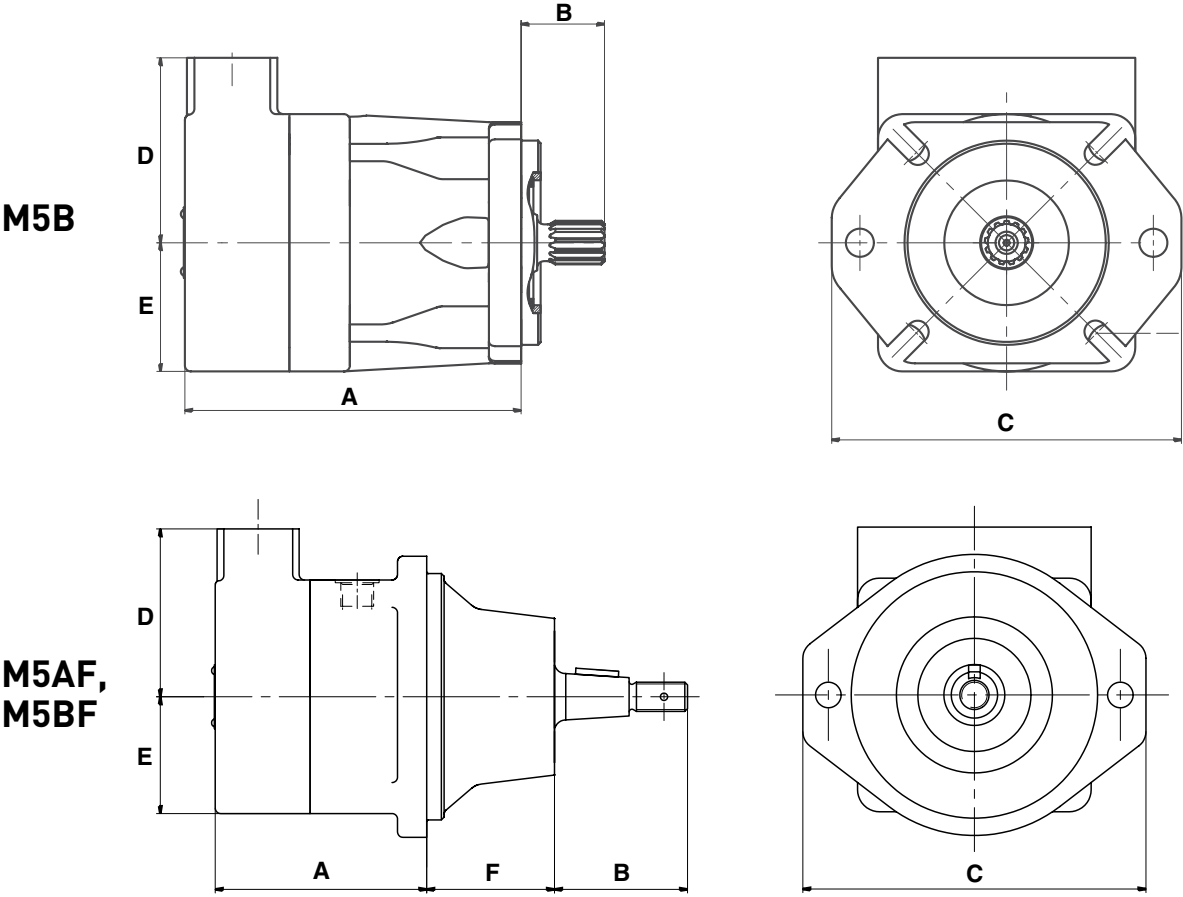

Dimensions, inch (mm)

Series	A	B	C	D	E	F	Weight, lb (kg)
M5AF	3.58 (90.9)	2.97 (75.4)	—	3.62 (91.9)	2.52* (64.1)	2.74 (69.6)	33.0 (15.0)
M5B	6.59 (167.4)	2.75 (69.8)	6.85 (174.0)	3.62 (91.9)	2.52 (64.1)	—	40.8 (18.5)
M5BF	4.56 (115.8)	2.87 (72.9)	7.40 (188.0)	3.62 (91.9)	2.52 (64.1)	2.75 (69.8)	40.8 (18.5)

\* For relief valve option, add 2.66" (67.6 mm) max.



# Motors

## M5 Model Ordering Code

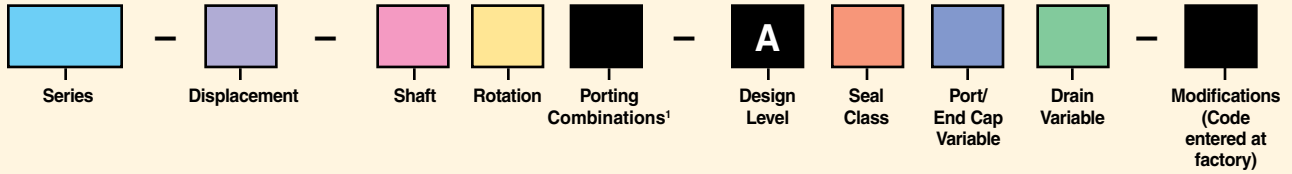

Code	Series Description
M5AF	Fan Motor, External Drain
M5AF1	Fan Motor, Internal Drain
M5B	ISO Flange
M5BS	SAE Flange
M5BF	Fan Motor, External Drain
M4BF1	Fan Motor, Internal Drain

M5AF Codes	Displacement in <sup>3</sup> /rev (cm <sup>3</sup> /rev)	M5B/M5BF Codes	Displacement in <sup>3</sup> /rev (cm <sup>3</sup> /rev)
006	0.38 (6.2)	012	0.73 (12)
010	0.61 (10)	018	1.10 (18)
012	0.76 (11.1)	023	1.40 (22.9)
016	0.98 (16.1)	028	1.71 (28)
018	1.10 (18)	036	2.20 (36.1)
025	1.52 (24.9)	045	2.75 (45.1)

Code	Shaft Type		
	M5AF/1	M5B/S	M5BF/1
1	Taper (non SAE)	Keyed SAE B J744	Keyed Taper (non SAE)
2	Keyed (non SAE)	Keyed ISO E25M - 3019-2	Keyed SAE C J744c
3		Splined SAE B J498	
4		Splined SAE BB J498	
W			Keyed ISO G32N

Code	Rotation
N*	Bi-directional
R**	CW
L**	CCW

\* Not available on M5AF1, M5BF1.

\*\* Viewed from shaft end; not available on M5B, M5BS.

Code	Seal Class
1	S1 Buna N
5	S5 Fluorocarbon

Code	Port/End Cap Variables	
	M5AF End Cap Variables**	M5B/S, M5BF/1 Port Variables
0	4 Bolt SAE Flange (J518) UNC Thread	3/4" SAE 4 Bolt Flange (J518c), UNC Thread†
M	4 Bolt SAE Flange (J518) Metric Thread	3/4" SAE 4 Bolt Flange (J518c), Metric Thread
Y	Metric Threaded Ports (ISO 6149) M22x1.5	
W	SAE Str. Threaded Ports 1-1/6"-12 UNF-2B	
A*	4 Bolt SAE Flange (J518) Metric Thread, 3045.79 PSI (210 bar)	
B*	4 Bolt SAE Flange (J518) Metric Thread, 2030.53 PSI (140 bar)	
C*	4 Bolt SAE Flange (J518) Metric Thread, 1015.26 PSI (70 bar)	

\* Motors with proportional pressure relief valve only (external drain and uni-rotational only)

\*\* All uni-rotational motors have an internal check valve included.

† Not available on M5BF1.

Code	Drain Variables				
	M5AF	M5AF1	M5B/S	M5BF	M5BF1
2	9/16" SAE		9/16" SAE	9/16" SAE	
3	M12 x 1.5 Metric		M18 x .06 Metric	M18 x .06 Metric	
X		No Drain			No Drain

† Several combinations available. See catalog on CD

= Not Available

## Calzoni



**MR-MRE Low Speed High Torque Small Displacement Radial Piston Motors**

The outstanding performance of this robust product is the result of our original, patented design. Used widely in the injection molding, mining, off shore drilling, oil field, and marine markets, the Parker Calzoni motor is produced in sizes from 32cc up to 23034cc per revolution. The efficiency of our design allows for

a smaller installed product for the same displacement vs. our competitors. Since there are no internal connecting rods, we have greatly reduced frictional drag as well as most thrust loading. By creating a static balance on the shaft we have extended the expected lifetime as well.



**MRT-MRTE-MRTF Low Speed High Torque Large Displacement Radial Piston Motors**



**MRD-MRDE, MRV-MRVE Low Speed High Torque Variable Displacement Radial Piston Motors**

## Performance Data

Series	Displacement in <sup>3</sup> /rev (cc/rev)	Max. Pressure PSI (BAR)	Max. Speed RPM	Torque (in-lb/PSI)
MR	1.96 - 425.16 (32.1 - 6967.2)	4350 (300)	1400	0.025 - 5.665
MRE	20.28 - 502.01 (332.4 - 8226.4)	3600 (250)	750	0.270 - 6.657
MRT	433.27 - 1190.45 (7100 - 19508)	4350 (300)	150	5.75 - 15.79
MRTE/MRTF	476.47 - 1405.62 (7808 - 23034)	3600 (250)	130	6.32 - 18.64

Series	Displacement in <sup>3</sup> /rev (cc/rev)	Max. Pressure PSI (BAR)	Max. Speed RPM	Min. Torque (in-lb/PSI)	Max. Torque (in-lb/PSI)
MRD/MRV	18.56 - 419.05 (304.1 - 6867)	4350 (300)	1100	0.123 - 1.823	0.244 - 3.646
MRDE/MRVE	20.28 - 501.98 (332.4 - 8226)	3600 (250)	1000	0.135 - 2.187	0.270 - 4.374



## MR-MRE Low Speed High Torque Small Displacement Radial Piston Motors

### Performance Data

Series	Displacement in <sup>3</sup> /rev (cc/rev)	Max. Pressure PSi (BAR)	Max. Speed RPM	Torque (in-lb/PSI)
MR33	1.96 (32.1)	4350 (300)	1800	0.025
MR57	3.44 (56.4)	4350 (300)	1600	0.046
MR73	4.43 (72.6)	4350 (300)	1200	0.061
MR93	5.65 (92.6)	4350 (300)	1150	0.076
MR110	6.65 (109.0)	4350 (300)	1100	0.087
MR125	7.61 (124.7)	4350 (300)	900	0.102
MR160	9.75 (159.7)	4350 (300)	900	0.129
MR190	11.69 (191.6)	4350 (300)	850	0.155
MR200	12.16 (199.2)	4350 (300)	800	0.163
MR250	15.31 (250.9)	4350 (300)	800	0.203
MR300	18.56 (304.4)	4350 (300)	750	0.244
MR350	21.33 (349.5)	4350 (300)	640	0.283
MR450	27.56 (451.6)	4350 (300)	600	0.366
MR600	37.10 (607.9)	4350 (300)	520	0.493
MR700	43.09 (706.9)	4350 (300)	500	0.575
MR1100	68.7 (1125.8)	4350 (300)	330	0.910
MR1600	97.54 (1598.4)	4350 (300)	260	1.292
MR1800	110.43 (1809.6)	4350 (300)	250	1.465
MR2400	139.93 (2293.1)	4350 (300)	220	1.937
MR2800	170.38 (2792.0)	4350 (300)	215	2.263
MR3600	221.93 (3636.8)	4350 (300)	180	2.944
MR4500	274.77 (4502.7)	4350 (300)	170	3.346
MR6500	394.24 (6460.5)	4350 (300)	130	5.267
MR7000	425.16 (6967.2)	4350 (300)	130	5.665
MRE330	20.28 (332.4)	3600 (250)	750	0.270
MRE500	30.38 (497.9)	3600 (250)	600	0.403
MRE800	49.08 (804.2)	3600 (250)	450	0.651
MRE1400	83.57 (1369.5)	3600 (250)	280	1.109
MRE2100	127.61 (2091.2)	3600 (250)	250	1.693
MRE3100	189.40 (3103.7)	3600 (250)	215	2.512
MRE5400	329.6 (5401.2)	3600 (250)	160	4.374
MRE8200	502.0 (8226.4)	3600 (250)	130	6.657

## MR-MRE Low Speed High Torque Small Displacement Radial Piston Motors

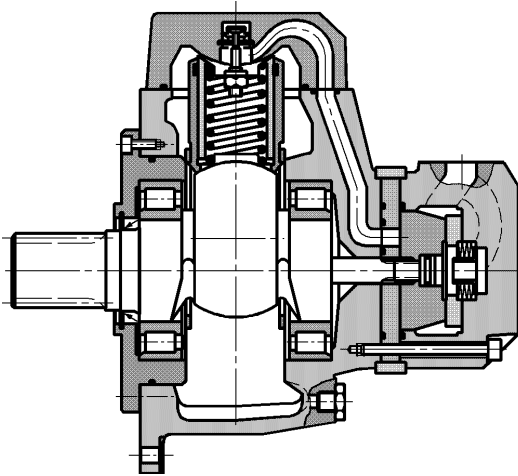

### Benefits/Features

- 5-piston design
- Wide range of displacements
- Starting torque from 90-95% theoretical
- Total efficiency up to 96%
- Resistance to thermal shocks  
T = 176°F
- Speed feedback accessories optional

### Dimensions, inch (mm)

Series	A	C Max.	D
MR33 MR57	7.72 (196.1)	2.25 (57.2)	9.27 (235.5)
MR73 MR93 MR110	9.0 (228.6)	2.70 (68.6)	9.84 (249.9)
MR125 MR160 MR190	9.53 (242.1)	2.64 (67.1)	12.33 (313.2)
MR200 MR250 MR300 MRE330	9.53 (242.1)	3.19 (81.0)	12.91 (327.9)
MR350 MR450 MRE500	10.98 (178.9)	3.82 (97.0)	14.49 (368.0)
MR600 MR700 MRE800	11.77 (299.0)	3.98 (101.1)	15.95 (405.1)
MR1100 MRE1400	13.43 (341.1)	4.61 (117.1)	18.5 (469.9)
MR1600 MR1800 MRE2100	14.72 (373.9)	5.20 (132.1)	21.97 (558.0)
MR2400 MR2800 MRE3100	18.35 (466.1)	6.02 (152.9)	25.28 (642.1)
MR3600 MR4500 MRE5400	19.27 (489.5)	8.27 (210.1)	30.16 (766.1)
MR6500 MR7000 MRE8200	22.28 (565.9)	9.06 (230.1)	34.02 (864.1)

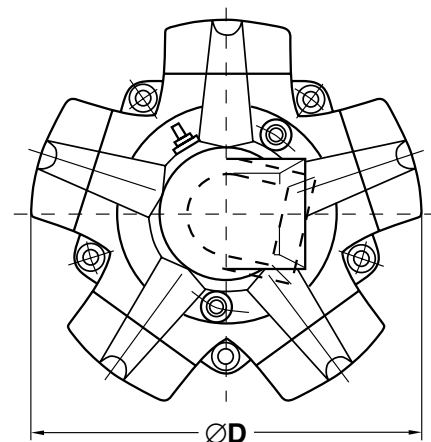
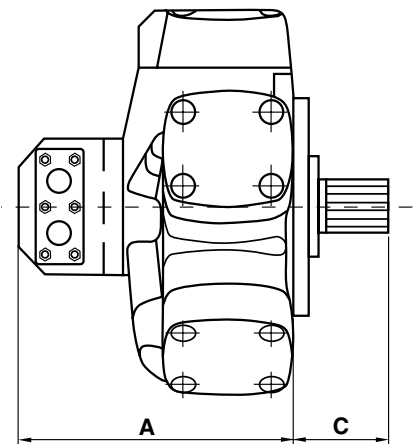





# Motors

## MR/MRE Model Ordering Code

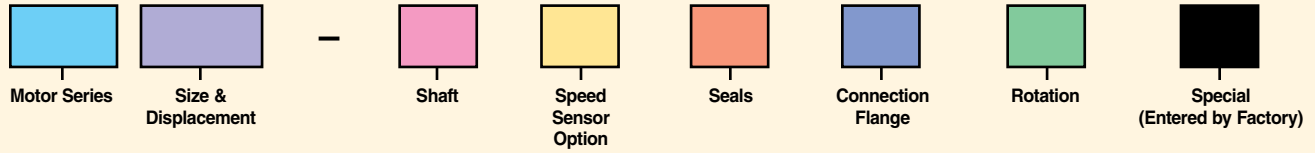

Code	Motor Series
MR	Standard 3626 PSI (250.0 BAR) Max. Continuous
MRE	Expanded 3026 PSI (208.6 BAR) Max. Continuous

Size & Displacement			
Code	Displacement in <sup>3</sup> (cm <sup>3</sup> )	MR	MRE
33A	1.96 (32.1)	x	—
57A	3.44 (56.4)	x	—
73B	4.43 (72.6)	x	—
93B	5.65 (92.6)	x	—
110B	6.65 (109.0)	x	—
125C	7.61 (124.7)	x	—
160C	9.75 (159.8)	x	—
190C	11.69 (191.6)	x	—
200D	12.16 (199.3)	x	—
250D	15.31 (250.9)	x	—
300D	18.56 (304.5)	x	—
330D	20.28 (332.3)	—	x
350E	21.33 (349.5)	x	—
450E	27.56 (451.6)	x	—
500E	30.38 (497.8)	—	x
600F	37.10 (608.0)	x	—
700F	43.09 (706.1)	x	—
800F	49.08 (804.3)	—	x
1100G	68.7 (1126)	x	—
1400G	83.6 (1370)	—	x
1600H	97.5 (1598)	x	—
1800H	110.4 (1809)	x	—
2100H	127.6 (2091)	—	x
2400I	139.9 (2292)	x	—
2800I	170.4 (2792)	x	—
2100I	189.4 (3104)	—	x
3600L	221.9 (3636)	x	—
4500L	274.8 (4503)	x	—
5400L	329.6 (5401)	—	x
6500M	394.2 (6460)	x	—
7000M	408.7 (6697)	x	—
8200M	502.0 (8226)	—	x

Code	Shaft
N1	Spline Ex DIN 5463
D1	Spline DIN 5480
F1	Female Spline DIN 5480
P1	Shaft with Key
B1	Spline B.S. 3550

Code	Speed Sensor Option
N1	None
Q1	Encoder Drive
C1	Mechanized Tachometer Drive
T1	Tachometer Drive
M1	Incremental Elcis Encoder, Uni-directional*
B1	Incremental Elcis Encoder, Bi-directional*

\* 500 pulse/rev

Code	Seals
N1	NBR Mineral Oil
F1	NBR, 218 PSI (15.0 BAR) Shaft Seal
V1	Fluorocarbon
U1	No Shaft Seal (for Brake)

Code	Connection Flange
N1	None
C1	Standard DENISON Calzoni
S1	Standard SAE Metric
T1	Standard SAE UNC
G1	SAE 6000 PSI (413.7 BAR) Metric
L1	SAE 6000 PSI (413.7 BAR) UNC

Code	Rotation
N	Standard Rotation (CW: Inlet in A; CCW: Inlet in B)
S	Reversed Rotation (CW: Inlet in B; CCW: Inlet in A)

## MRT-MRTE-MRTF Low Speed High Torque Large Displacement Radial Piston Motors

### Performance Data

Series	Displacement in <sup>3</sup> /rev (cc/rev)	Max. Pressure PSI (BAR)	Max. Speed RPM	Torque (in-lb/PSI)
MRT7100	433.29 (7100.4)	4350 (300)	150	5.75
MRTF7800	476.50 (7808.4)	3600 (250)	130	6.32
MRTE8500	519.76 (8517.3)	3600 (250)	120	6.90
MRT9000	549.54 (9005.4)	4350 (300)	130	7.29
MRTF9900	604.37 (9903.9)	3600 (250)	120	8.02
MRTE10800	659.20 (10802.4)	3600 (250)	110	8.75
MRT14000	854.94 (14010)	4350 (300)	80	11.34
MRTF15500	932.20 (15276)	3600 (250)	75	12.36
MRTE16500	1009.46 (16542)	3600 (250)	70	13.39
MRT17000	1022.70 (16759)	4350 (300)	70	14.58
MRTF18000	1099.95 (18025)	3600 (250)	65	14.59
MRT19500	1190.45 (19508)	4350 (300)	60	15.79
MRTE20000	1207.54 (19788)	3600 (250)	60	16.01
MRTF21500	1298.04 (21271)	3600 (250)	55	17.21
MRTE23000	1405.62 (23034)	3600 (250)	50	18.64

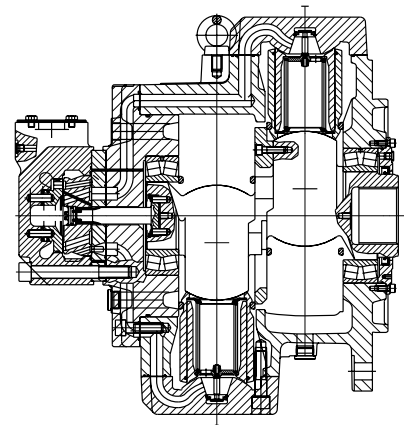

10-Piston Design

### Benefits/Features

- Hydraulically balanced 10 and 14-piston twin row design
- Wide range of displacements
- Starting torque from 91% theoretical
- Total efficiency up to 96%
- Speed feedback accessories optional

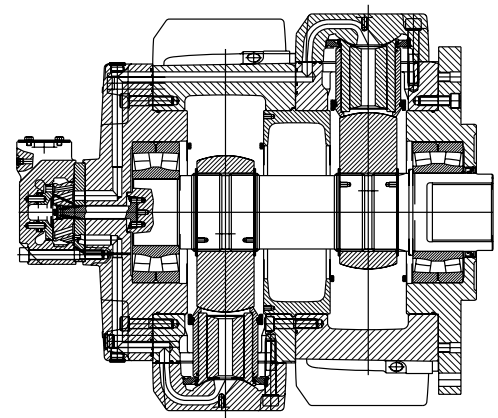

14-Piston Design

## MRT-MRTE-MRTF Low Speed High Torque Large Displacement Radial Piston Motors

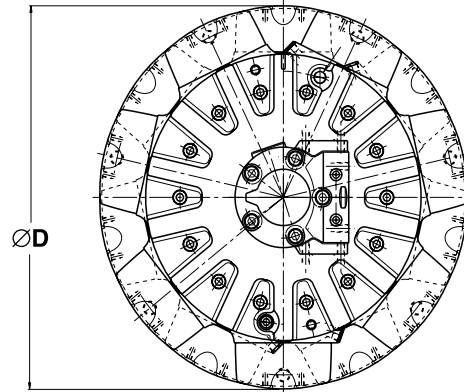
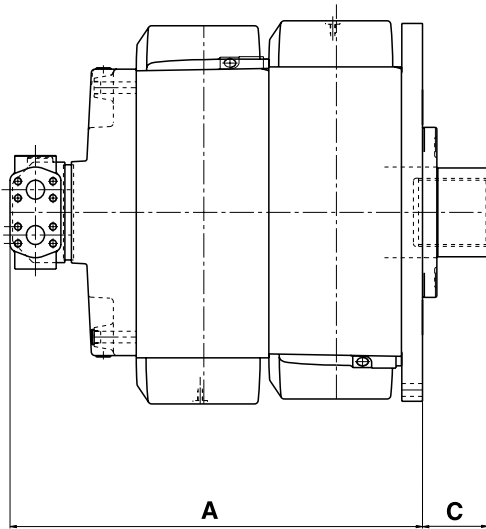
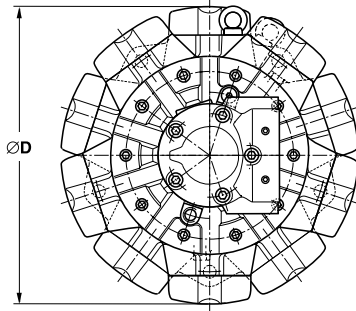
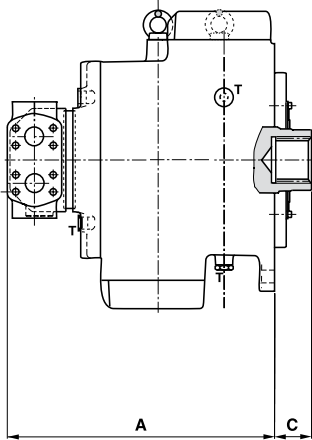

### Dimensions, inch (mm)

Series			A	C Max.	D
MRT7100	MRTE8500	MRTF7800	27.106	1.969	30.157
MRT9000	MRTE10800	MRTF9900	(688.5)	(50.0)	(766.0)
MRT1400	MRTE16500	MRTF1550	44.705	3.15	39.921
MRT17000	MRTE20000	MRTF18000	(1135.5)	(80.0)	(1014.0)
MRT19500	MRTE23000	MRTF21500			

# Motors

## MRT-MRTE-MRTF Model Ordering Code



Code	Motor Series
MRT	Standard 3626 PSI (250.0 BAR) Max. Continuous
MRTE MRTF	Expanded 3026 PSI (208.6 BAR) Max. Continuous

Size & Displacement				
Code	Displacement in <sup>3</sup> (cm <sup>3</sup> )	MRT	MRTE	MRTF
7100P	433.3 (7103)	x	—	—
7800P	476.5 (7808)	—	—	x
8500P	529.8 (8518)	—	x	—
9000P	549.5 (9005)	x	—	—
9800P	604.4 (9904)	—	—	x
10800P	659.2 (10802)	—	x	—
14000Q	854.9 (14009)	x	—	—
15500Q	832.3 (15278)	—	—	x
16500Q	1009.5 (16543)	—	x	—
17000Q	1022.7 (16759)	x	—	—
18000Q	1100.0 (18026)	—	—	x
19500Q	1190.5 (19509)	x	—	—
20000Q	1207.5 (19787)	—	x	—
21500Q	1298.0 (21270)	—	—	x
23000Q	1405.6 (23034)	—	x	—

Code	Shaft
D1	Spline DIN 5480
F1	Female Spline DIN 5480

Code	Speed Sensor Option
N1	None
Q1	Encoder Drive
C1	Mechanized Tachometer Drive
T1	Tachometer Drive
M1	Incremental Elcis Encoder, Uni-directional*
B1	Incremental Elcis Encoder, Bi-directional*

\* 500 pulse/rev

Code	Seals
N1	NBR Mineral Oil
F1	NBR, 218 PSI (15.0 BAR) Shaft Seal
V1	Fluorocarbon
U1	No Shaft Seal (for Brake)

Code	Connection Flange
S1	Standard SAE Metric
G1	SAE 6000 PSI (413.7 BAR) Metric
M1	SAE 6000 PSI (413.7 BAR) Metric Special Timing

Code	Rotation
N	Standard Rotation (CW: Inlet in A; CCW: Inlet in B)
S	Reversed Rotation (CW: Inlet in B; CCW: Inlet in A)

## MRD-MRDE, MRV-MRVE Low Speed High Torque Variable Displacement Radial Piston Motors

### Performance Data

Series	Displacement in <sup>3</sup> /rev (cc/rev)	Max. Pressure PSI (BAR)	Max. Speed RPM	Min-Max Torque (in-lb/PSI)
MRD300 —	18.56 (304.1)	4350 (300)	1000	0.123 0.244
MRD450 —	27.56 (451.6)	4350 (300)	850	0.183 0.366
— MRV450	27.56 (451.6)	4350 (300)	850	0.107 0.366
MRD700 MRV700	43.14 (706.9)	4350 (300)	700	0.275 0.575
MRD1100 MRV1100	68.70 (1125.8)	4350 (300)	580	0.412 0.910
MRD1800 MRV1800	110.43 (1809.6)	4350 (300)	400	0.733 1.465
MRD2800 MRV2800	170.38 (2792.0)	4350 (300)	280	1.130 2.263
MRD4500 MRV4500	274.77 (4502.7)	4350 (300)	250	1.823 3.646
MRDE330 —	20.28 (332.4)	3600 (250)	1000	0.135 0.270
MRDE500 —	30.38 (497.9)	3600 (250)	800	0.201 0.403
MRDE800 MRVE800	20.28 (804.2)	3600 (250)	650	0.313 0.651
MRDE1400 MRVE1400	83.57 (1369.5)	3600 (250)	550	0.501 1.109
MRDE2100 MRVE2100	127.61 (2091.2)	3600 (250)	370	0.847 1.693
MRDE3100 MRVE3100	189.40 (3103.7)	3600 (250)	280	1.257 2.512
MRDE5400 MRVE5400	329.60 (5401.2)	3600 (250)	210	2.187 4.374

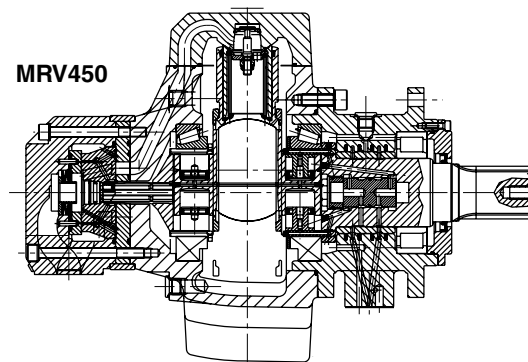
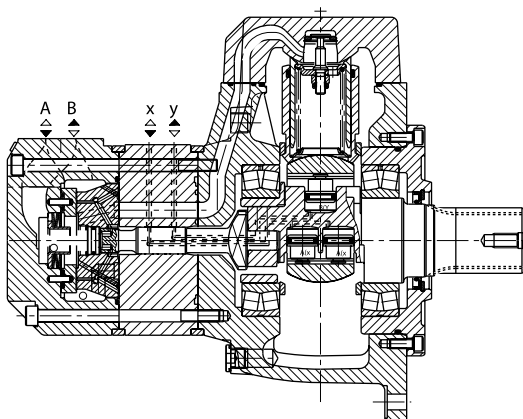

### Benefits/Features

- 5-piston design
- Displacement ratios of 1:2 or 1:3
- Starting torque from 90-95% theoretical
- Total efficiency up to 96%
- Resistance to thermal shocks  
T = 176°F
- Speed feedback accessories optional

## MRD-MRDE, MRV-MRVE Low Speed High Torque Variable Displacement Radial Piston Motors

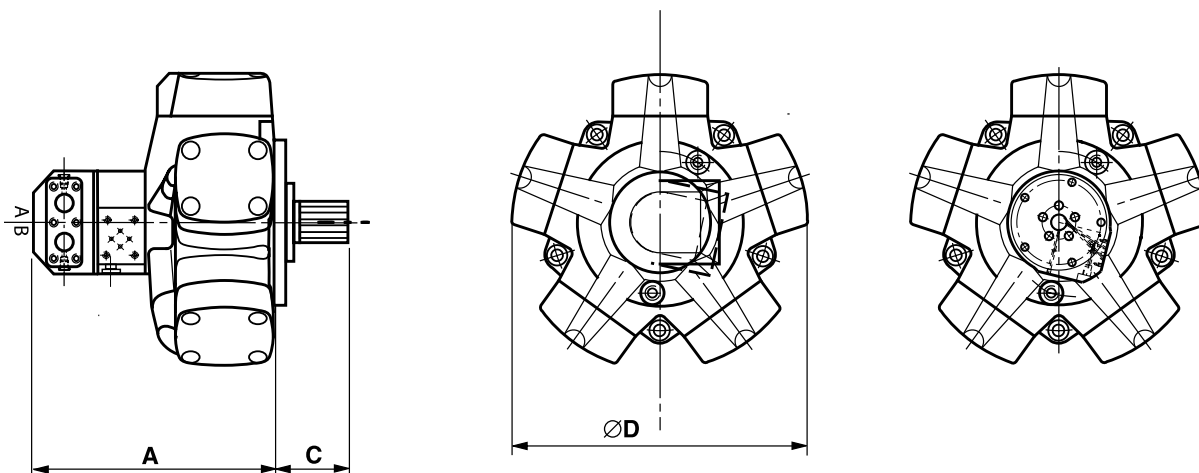

### Dimensions, inch (mm)

Series	A	C Max.	D
MRD300 MRDE330	11.10 (281.9)	3.19 (81.0)	12.91 (327.9)
MRD450 MRDE500	12.95 (328.9)	3.82 (97.0)	14.49 (368.0)
MRV450	16.06 (407.9)	4.33 (110.0)	14.49 (368.0)
MR*700 MR*E800	13.74 (349.0)	3.98 (101.1)	15.94 (404.9)
MR*1100 MR*E1400	15.79 (401.1)	4.61 (117.1)	18.50 (469.9)
MR*1800 MR*E2100	17.09 (434.1)	5.20 (132.1)	21.97 (558.0)
MR*2800 MR*E3100	20.71 (526.0)	6.02 (152.9)	25.28 (642.1)
MR*4500 MR*E5400	20.71 (526.0)	8.27 (210.1)	30.16 (766.1)

\* MRD and MRV



# Motors

## MRD-MRDE, MRV-MRVE Model Ordering Code

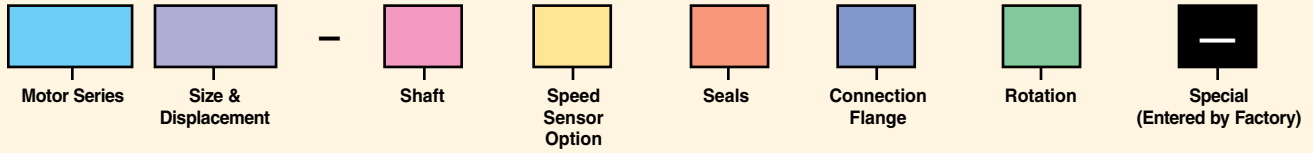

Code	Motor Series
<b>MRD</b>	Dual, Standard 3626 PSI (250.0 BAR) Max. Continuous
<b>MRDE</b>	Dual, Expanded 3026 PSI (208.6 BAR) Max. Continuous
<b>MRV</b>	Variable, Standard 3626 PSI (250.0 BAR) Max. Continuous
<b>MRVE</b>	Variable, Expanded 3026 PSI (208.6 BAR) Max. Continuous

Code	Speed Sensor Option
<b>N1</b>	None
<b>Q1</b>	Encoder Drive
<b>C1</b>	Mechanized Tachometer Drive
<b>T1</b>	Tachometer Drive
<b>M1</b>	Incremental Elcis Encoder, Uni-directional*
<b>B1</b>	Incremental Elcis Encoder, Bi-directional*

\*500 pulse/rev

Size & Displacement					
Code	Displacement in <sup>3</sup> /rev (cc/rev)	MRD	MRDE	MRV	MRVE
<b>300 D 150</b>	18.56 / 9.28 (304.1 / 152.1)	x	—	—	—
<b>330 D 165</b>	20.28 / 10.14 (332.4 / 166.2)	—	x	—	—
<b>450 E 133</b>	27.56 / 8.12 (451.6 / 133)	—	—	x	—
<b>450 E 225</b>	27.56 / 13.78 (451.6 / 225.8)	x	—	—	—
<b>500 E 250</b>	30.38 / 15.19 (497.9 / 248.9)	—	x	—	—
<b>700 F 235</b>	43.14 / 14.38 (706.9 / 235.6)	x	—	x	—
<b>800 F 270</b>	49.08 / 16.36 (804.2 / 268.1)	—	x	—	x
<b>1100 G 375</b>	68.70 / 22.90 (1125.8 / 375.3)	x	—	x	—
<b>1400 G 450</b>	83.57 / 27.86 (1369.5 / 456.5)	—	x	—	x
<b>1800 H 600</b>	110.43 / 36.81 (1809.6 / 603.2)	x	—	x	—
<b>2100 H 700</b>	127.61 / 42.54 (2091.2 / 697.1)	—	x	—	x
<b>2800 I 930</b>	170.38 / 56.79 (2792.0 / 930.7)	x	—	x	—
<b>3100 I 1035</b>	189.40 / 63.14 (3103.7 / 1034.6)	—	x	—	x
<b>4500 L 1500</b>	274.77 / 91.59 (4502.7 / 1500.9)	x	—	x	—
<b>5400 L 1800</b>	329.60 / 109.87 (5401.2 / 1800.4)	—	x	—	x
<b>7000 M 2300</b>	425.15 / 141.72 (6967 / 2322.4)	x	—	x	—
<b>8200 M 2750</b>	501.98 / 167.33 (8226 / 2742.1)	—	x	—	x

Code	Seals
<b>N1</b>	NBR Mineral Oil
<b>F1</b>	NBR, 218 PSI (15.0 BAR) Shaft Seal
<b>V1</b>	Fluorocarbon
<b>U1</b>	No Shaft Seal (for Brake)

Code	Connection Flange
<b>N1</b>	None
<b>C1</b>	Standard Denison Calzoni
<b>S1</b>	Standard SAE Metric
<b>T1</b>	Standard SAE UNC
<b>G1</b>	SAE 6000 PSI (413.7 BAR) Metric
<b>L1</b>	SAE 6000 PSI (413.7 BAR) UNC

Code	Rotation
<b>N</b>	Standard Rotation (CW: Inlet in A; CCW: Inlet in B)
<b>S</b>	Reversed Rotation (CW: Inlet in B; CCW: Inlet in A)

Code	Shaft
<b>N1</b>	Spline Ex DIN 5463
<b>D1</b>	Spline DIN 5480
<b>F1</b>	Female Spline DIN 5480
<b>P1</b>	Shaft with Key
<b>B1</b>	Spline B.S. 3550







## Power Units

*Page*

**(M)** = Mobile **(I)** = Industrial **(B)** = Mobile & Industrial

<b>(I)</b>	<b>D-Pak 5 Gallon 0.9 - 2.7 GPM</b>	<b>143-144</b>
<b>(I)</b>	<b>H-Pak 10-40 Gallon, 0.9 - 9.6 GPM</b>	<b>145-152</b>
<b>(I)</b>	<b>V-Pak 10-40 Gallon, 2 - 15.6 GPM</b>	<b>145-152</b>
<b>(I)</b>	<b>V-Pak Low Profile 80 Gallon, 15-36 GPM</b>	<b>145-152</b>



ENGINEERING YOUR SUCCESS.

# Power Units (Industrial)



## D-Pak 5 Gallon



D-Pak style power units are ideal for many industrial applications. The space saving vertical style units are available with gear pumps and are designed for quiet and leak-free operation. Standard Parker filtration on each unit will help ensure a long service life.

## Power Unit Performance Data

Model Series	Tank (Gal)	Pump Flow, GPM (LPM) @ 1725 RPM	Electric Motor HP (KW)	Maximum Pressure PSI (BAR)
D-Pak	5	0.9 - 2.7 (3.4 - 10.2)	0.5 - 3 (0.37 - 2.24)	3000 (210)

## Markets

Industrial

## Applications

Presses, Shears, Test Equipment, Simulators

## Features

- Vertical design
- Submerged pump
- Spare return ports
- Precision pump mounting adapters
- Suction strainer
- Glycerine filled pressure gage with shut off
- Oil level gage with thermometer
- Relief valve
- Breather and fill cap
- SAE drain plug
- Parker connector technology

## Benefits

- Saves floor space
- Quieter operation, elimination of potential leak point
- Longer pump life
- Protects pump from contamination
- Improved diagnostics
- Helps to maintain trouble-free performance
- Protects against system shock
- Easy to fill reservoir
- Prevents leaks

\* Stainless units & other options available on request

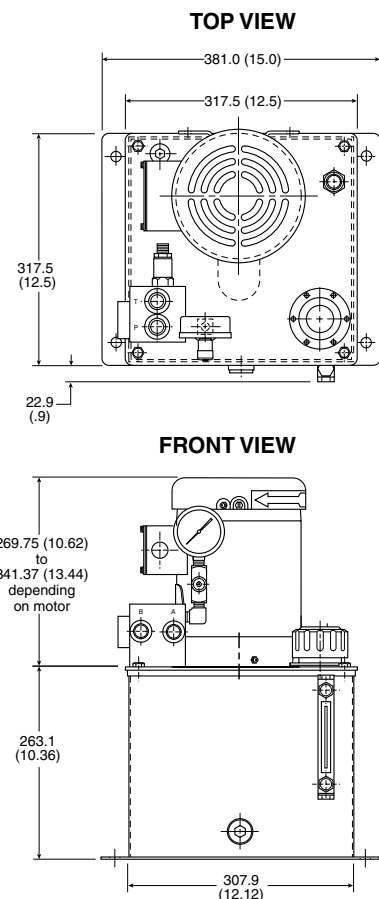



# Power Units

## D-Pak Model Ordering Code

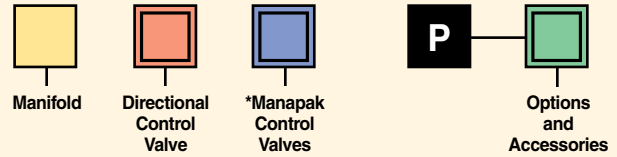
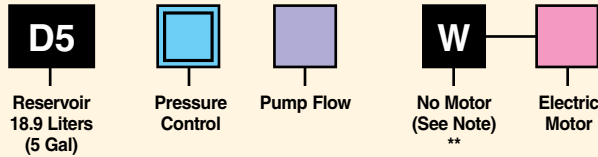

Code	Pressure Control
Omit	System Pressure Relief Valve Only
B	System Pressure Relief Valve with Unloading Valve (2-Way 120VAC) N.O. (Energize coil to close)
J	System Pressure Relief Valve with Unloading Valve (2-Way 24VDC) N.O. (Energize coil to close)

Code	Pump Flow Used
0.9	331-9110-267
1.3	331-9110-011
1.8	331-9110-010
2.7	331-9110-101

Code	Electric Motor Description HP (KW) - RPM - Frame - Phase
U1	.5 (.37) - 1725 - 56 C - 1
T1	1 (.75) - 1725 - 56 C - 1
T3	1 (.75) - 1725 - 56 C - 3
G	2 (1.5) - 1725 - 56 C - 3
K	3 (2.2) - 1725 - 56 C - 3

Single phase electric motors are rated as follows:  
115/230V, 1PH, TEFC - 60 Hz 1800 RPM

Three phase electric motors are rated as follows:  
200-230/460V, 3PH, TEFC - 60 Hz 1800 RPM

Consult factory for other motor speeds (RPM) and voltages.

\*\* Use W prefix when no motor is required on unit.  
When ordering, W must be followed by motor model code equivalent. Motor coupling will have interface for a 56C frame motor.

Code	Porting Block/Subplate or Manifold Type	Supply/Return Port or Actuator Port Size	Other
O	Pressure and Return Port Block with Safety Relief Valve	P & T Ports SAE-10 Str. Thr'd	Convertible to S3 Option
S3	D03 Single Station Subplate with Safety Relief Valve	A & B Ports SAE-8 Str. Thr'd	Spare P & T SAE-10 Ports
M33	D03 Multistation Parallel Circuit Manifold with Safety Relief Valve	A & B Ports SAE-8 Str. Thr'd	Spare G Port SAE-6

Manifolds are mounted vertically. Bottom station is number 1.

Code	Directional Control Valve Model Number	NFPA Mounting Pad	Nominal Flow GPM (LPM)	Description	Circuit Symbol
B	D1VW001CN***	D03	7 (26.5)	Double (Spr. Ctr)	
C	D1VW004CN***	D03	7 (26.5)	Double (Spr. Ctr)	
T	D1VW008CN***	D03	7 (26.5)	Double (Spr. Ctr)	

Units less valves will be supplied with station cover plates installed.

Code	Manapak Control Valves Function	Valve Model Number	NFPA Mounting Pad	Nominal Flow GPM (LPM)	Circuit Symbol
1	Flow Control Meter-Out	FM2DDKN	D03	7 (26.5)	
3	Pilot Operator Check	CPOM2DDN	D03	7 (26.5)	

Manapak valves mounted in order of callout.  
First valve will be nearest DCV; last valve will be on manifold.

Code	Options and Accessories		
	Function	Model Number	Technical Data
B1*	Exchanger	RM-08-2-2	Air/Oil: 0.7 HP (52 kW) Rej. @ 3 GPM (11.4 LPM)
H	Pressure Filter	15P110QXRS	Microglass II Element Vis. Ind. - 50 PSI (3.4 bar) Bypass - 2 PSI (0.14 bar) Diff. @ 3 GPM (11.4 LPM)
K	Check Valve Pump Outlet	DT370MOMF05	5 PSI (0.34 bar) Cracking Pressure 7 PSI (0.48 bar) Diff. @ 3 GPM (11.4 LPM)
L	Bypass Check (on Heat Exch)	C1020S65	65 PSI (4.5 bar) Cracking Pressure
O	Return Filter	12AT10C 45LPM (12 GPM)	Cellulose Element Ind. Gage - 15 PSI (1.03 bar) Bypass Max. Oil Flow
R1	Combination Float/Temp. Switch N.O. Float Up	8767820-1	Fixed Temp at 65°C (149°F) Close @ Low Level and/or 65°C (149°F) (N.O.)
R2	Combination Float/Temp. Switch Float Up	876782-02	Fixed Temp at 65°C (149°F) Open @ Low Level and/or 65°C (149°F) (N.C.)

\*Heat rejection based on flow given with a 40°F differential between transfer medium.

= Omit if not required

# Power Units



## H-Pak & V-Pak



**V-Pak Low Profile**

H-Pak and V-Pak style power units are ideal for many industrial applications. These space saving vertical style units are available with gear or piston pumps and are designed for quiet and leak-free operation. Standard Parker filtration on each unit will help ensure a long service life. Also available in V-Pak Low Profile.

## Performance Data

Model Series	Tank (Gal)	Pump Flow, GPM (LPM) @ 1725 RPM	Electric Motor HP (KW)	Max. Pressure PSI (BAR)
H-Pak	10, 20, 30, 40	0.9 - 9.6 (2.2 - 36.3)	0.5 - 20 (0.37 - 14.9)	3000 (210)
V-Pak	10, 20, 30, 40	2.0 - 15.6 (7.6 - 59.1)	2 - 20 (1.4 - 14.9)	3000 (210)
V-Pak Low Profile	80	36.1 (136.7)	7.5 - 40 (5.6 - 30)	3000 (210)

## Markets

Industrial

## Applications

Presses, Shears, Test Equipment, Simulators

\* Stainless units & other options available on request

## H-Pak and V-Pak

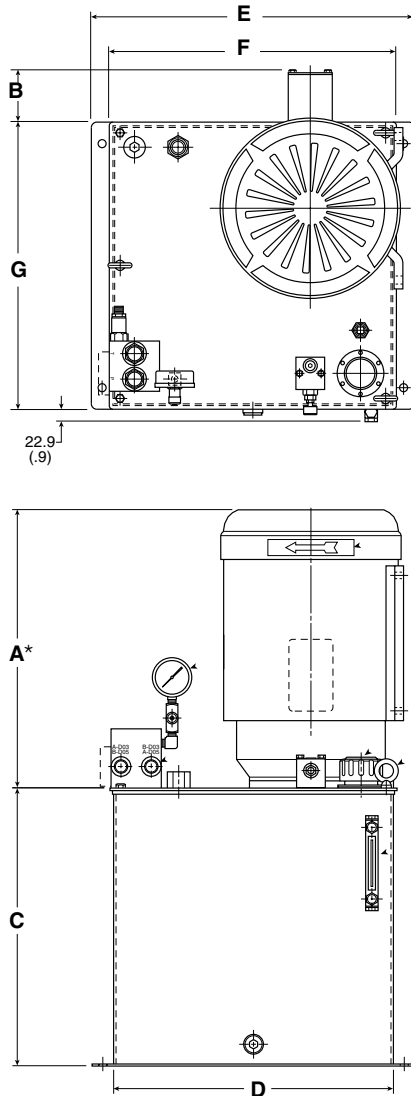

## Low Profile V-Pak

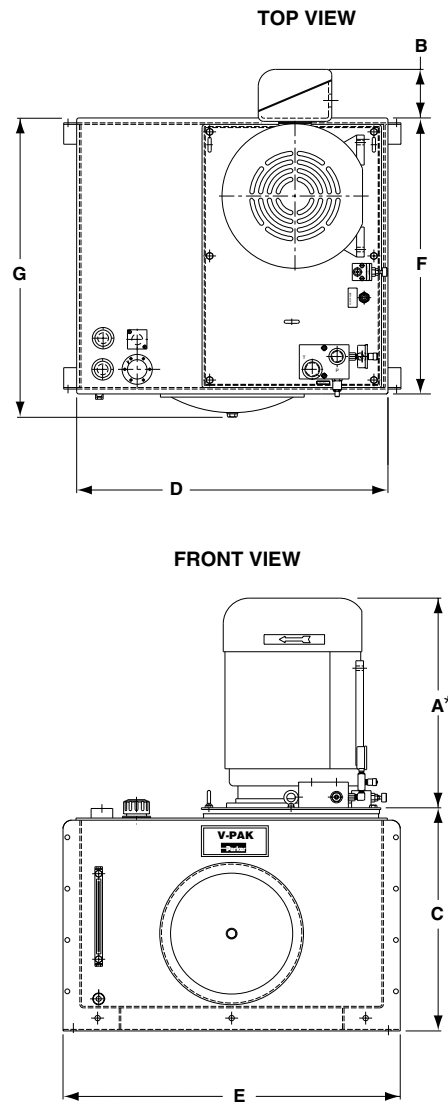

### Dimensions, inch (mm)

Series	H1/V1	H2/V2	H3/V3	H4/V4	V8
A <sup>††</sup>	10.5 (267) to 16.3 (414)	10.5 (267) to 19.3 (492)	11.8 (298) to 19.3 (492)	11.8 (298) to 19.3 (492)	16.6 (451) to 24.7 (627)
B <sup>*</sup>	0.8 (19) 2.6 (67)	0.8 (19) to 3.4 (85)	0.8 (19) to 3.4 (85)	0.8 (19) to 3.4 (85)	1.88 (48) to 5.7 (144)
C	15.4 (390)	19.4 (492)	23.6 (600)	28.9 (733)	28.6 (725)
D	16.1 (410)	19.5 (495)	19.5 (495)	19.5 (495)	36.0 (914)
E	19.0 (483)	22.5 (572)	22.5 (572)	22.5 (572)	39.0 (991)
F	16.6 (422)	20.0 (508)	20.0 (508)	20.0 (508)	32.3 (819)
G	16.6 (422)	20.0 (508)	20.0 (508)	20.0 (508)	34.6 (879)

\* Depending on motor option

† Reference dimensions consult factory if critical to application

# Power Units

## H-Pak Model Ordering Code



Reservoir



Pressure Control



Pump Flow



No Motor  
(See Note)  
\*\*



Electric Motor



Manifold

Code	Reservoir Size Gallons (Liters)
H1*	10 (37.9)
H2	20 (75.7)
H3	30 (113.6)
H4	40 (151.4)

\*Available up to 7.5 KW (10 HP) motor only.

Code	Pressure Control*
Omit	System Pressure Relief Valve Only
B	System Pressure Relief Valve with Unloading Valve (2-Way 120VAC) N.O. (Energize coil to close)
J	System Pressure Relief Valve with Unloading Valve (2-Way 24VDC) N.O. (Energize coil to close)

Code	Pump Flow Used
0.9	331-9110-267
1.3	331-9110-011
1.8	331-9110-010
2.7	331-9110-101
3.2	334-9111-069
4.5	334-9111-068
5.1	334-9111-067
6.3	334-9111-048
9.6	334-9111-065

Code	Electric Motor Description HP (KW) - RPM - Frame - Phase
U1*	.5 (.37) - 1725 - 56C - 1
T1	1 (.75) - 1725 - 56C - 1
T3	1 (.75) - 1725 - 56C - 3
G	2 (1.5) - 1725 - 56C - 3
K	3 (2.2) - 1725 - 56C - 3
L	5 (37.5) - 1725 - 184TC - 3
M	7.5 (5.6) - 1725 - 213TC - 3
N	10 (7.5) - 1725 - 215TC - 3
P †	15 (11.2) - 1725 - 254TC - 3
S †	20 (14.9) - 1725 - 256TC - 3

\* U1 leadtime is 2 weeks

Single phase electric motors are rated as follows:  
115/230V, 1PH, TEFC - 60 Hertz 1800 RPM

Three phase electric motors are rated as follows:  
208-230/460V, 3PH, TEFC - 60 Hertz 1800 RPM

Consult factory for other motor speeds (RPM) and voltages.

† Available with H2, H3 and H4 tanks only.

\*\* Use W prefix when no motor is required on unit.  
When ordering, W must be followed by motor model code equivalent to frame size of motor to be used.

Code	Porting Block/Subplate or Manifold Type	Supply/Return Port or Actuator Port Size	Other
O	Pressure and Return Port Block with Safety Relief Valve	P & T Ports SAE-10 Str. Thr'd	Convertible to S3 Option
S3	D03 Single Station Subplate with Safety Relief Valve	A & B Ports SAE-8 Str. Thr'd	Spare P & T SAE-10 Ports
S5	D05 Single Station Subplate with Safety Relief Valve	A & B Ports SAE-10 Str. Thr'd	Spare P & T SAE-12 Ports
M33 M35	D03 Multistation Parallel Circuit Manifold with Safety Relief Valve	A & B Ports SAE-8 Str. Thr'd	Spare G Port SAE-6
M53 M55	D05 Multistation Parallel Circuit Manifold with Safety Relief Valve	A & B Ports SAE-8 Str. Thr'd	Spare G Port SAE-6

Manifolds are mounted vertically. Bottom station is number 1.

= Omit if not required



# Power Units

## H-Pak Model Ordering Code



Directional Control Valve



\*Manapak Control Valves

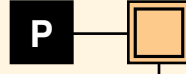

Options and Accessories

Code	Valve Model Number	NFPA Mounting Pad	Nominal Flow GPM (LPM)	Description	Circuit Symbol
B	D1VW001CN***	D03	7 (26.5)	Double (Spr. Ctr)	
C	D1VW004CN***	D03	7 (26.5)	Double (Spr. Ctr)	
F	D3W1CN**	D05	20 (75.7)	Double (Spr. Ctr)	
G	D3W4CN**	D05	15 (56.8)	Double (Spr. Ctr)	
T	D1VW008CN***	D03	7 (26.5)	Double (Spr. Ctr)	
W	D3W8CN**	D05	15 (56.8)	Double (Spr. Ctr)	

Units less valves will be supplied with station cover plates installed.

Code	Function	Valve Model Number	NFPA Mounting Pad	Nominal Flow GPM (LPM)	Circuit Symbol
1	Flow Control	FM2DDKN	D03	7 (26.5)	
2	Flow Control	FM3DDKN	D05	12 (45.4)	
3	Pilot Operator Check	CPOM2DDN	D03	7 (26.5)	
4	Pilot Operator Check	CPOM3DDN	D05	12 (45.4)	

\*Manapak valves mounted in order of callout.

First valve will be nearest DCV; last valve will be on manifold.

Code	Function	Model Number	Technical Data
B1*	Return Heat Exchanger	RM-08-1-2	Air/Oil: .7 HP (0.52 kW), Rej. @ 7 GPM (26.5 LPM) 0.37 - 3.7 kW Motors only
B2*	Return Heat Exchanger	RM 190-1-2	Air/Oil: 1.5 HP (1.1 kW), Rej. @ 7 GPM (26.5 LPM) 5.6 - 11.2 kW Motors only
H	Pressure Filter	15P110QXRS	Microglass II Element, Vis. Ind. - 50 PSI (3.49 bar) Bypass - 4 PSI (0.27 bar), Diff. @ 7 GPM (26.5 LPM)
K	Check Valve Pump Outlet	"DT" & "C" Series	5 PSI (0.34 bar) Cracking Pressure 25 PSI (1.72 bar) Diff. @ 15 GPM (56.8 LPM)
L	Bypass Check (on Heat Exch)	C1220S65	(65 PSI) 4.5 bar Cracking Pressure
O	Return Filter	12AT10C 12 GPM (45 LPM)	Cellulose Element, Ind. Gage - 15 PSI (1.03 bar) Bypass
R1	Combination Float/Temp. Switch N.O. Float Up	876782-01	Fixed Temp at 65°C (149°F) Close @ Low Level and/or 65°C (149°F) (N.O.)
R2	Combination Float/Temp. Switch Float Up	876782-02	Fixed Temp at 65°C (149°F) Open @ Low Level and/or 65°C (149°F) (N.C.)

\*Heat rejection based on flow given with a 40°F differential between transfer medium.

= Omit if not required

# Power Units

## V-Pak Model Ordering Code



Reservoir



Pressure Control



Pump Control

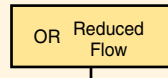

Pump Flow



No Motor  
(See Note)  
\*\*



Electric Motor



Manifold

Code	Reservoir Size Gallons (Liters)
V1*	10 (37.9)
V2	20 (75.7)
V3	30 (113.6)
V4	40 (151.4)

\*Available up to 10 HP (7.5 kW) motor only.

Code	Pressure Control
Omit	Single Pressure Remote Compensator
B	Single Pressure Remote Compensator with Low Pressure Standby
BJ	Single Pressure Remote Compensator with Low Pressure Standby, 24 VDC
C	Bi-Pressure Remote Compensator
CJ	Bi-Pressure Remote Compensator, 24VDC
D	Bi-Pressure Remote Compensator with Low Pressure Standby
DJ	Bi-Pressure Remote Compensator with Low Pressure Standby, 24VDC
F	Provision for Customer Supplied Remote Control Relief Valve

Code	Pump Control
Omit	Std. Remote Compensator
A*	Load Sense Flow Control
H**	Horsepower Limiting

\*A\_SAE-6 sense port line will be supplied in topplate.

\*\* Horsepower setting will be at max. flow & pressure obtainable with motor selected. Lead time is four weeks for shaded items.

Code	Pump Flow Rate @1800 RPM	Pump Used and Description
7	7 GPM (29.5 LPM)	PVP16 - Std. Remote Compensator
*	Specify in GPM	Destroyed Max. Volume – 2 GPM Min.
15	15.6 GPM (59 LPM)	PVP33 - Std. Remote Compensator
**	Specify in GPM	Destroyed Max. Volume – 8 GPM Min.

\*Unless otherwise specified, units are shipped at max. flow rate 7.8 GPM (29.5 LPM) at 1800 RPM. When reduced flow setting is required, specify pump setting in .5 GPM (1.9 LPM) increments. Example: 5, 5.5, 6, 6.5 with a 2 GPM (7.6 LPM) minimum flow.

\*\*Unless otherwise specified, units are shipped at max. flow rate 15.6 GPM (59 LPM) at 1800 RPM. When reduced flow setting is required, specify pump setting in .5 GPM (1.9 LPM) increments. Example: 11, 11.5, 12, 12.5 with a 8 GPM (30.3 LPM) minimum flow.

Example: V\*12\*\*-- = Std. Pump Destroyed to 12 GPM (45.4 LPM)  
V\*A11.5\*\*\*-- = Load Sense Pump Destroyed to 11.5 GPM (43.5 LPM)

Code	Electric Motor Description HP (KW) - RPM - Frame - Phase
G	2 (1.5) - 1725 - 56C - 3
K	3 (2.2) - 1725 - 56C - 3
L	5 (37.5) - 1725 - 184TC - 3
M	7.5 (5.6) - 1725 - 213TC - 3
N	10 (7.5) - 1725 - 215TC - 3
P †	15 (11.2) - 1725 - 254TC - 3
S †	20 (14.9) - 1725 - 256TC - 3

Electric motors are 208-230/460V, 60 Hz 3PH 1800 RPM TEFC. Consult factory for other motor speeds (RPM) and voltages.

†Available with V2, V3 and V4 tanks only.

\*\* Use W prefix when no motor is required on unit. When ordering, W must be followed by motor model code equivalent to frame size of motor to be used.

Code	Porting Block/Subplate or Manifold Type	Supply/Return Port or Actuator Port Size	Other
O	Pressure and Return Port Block with Safety Relief Valve	P & T Ports SAE-10 Str. Thr'd	Convertible to S3 Option
S3	D03 Single Station Subplate with Safety Relief Valve	A & B Ports SAE-8 Str. Thr'd	Spare P & T SAE-10 Ports
S5	D05 Single Station Subplate with Safety Relief Valve	A & B Ports SAE-10 Str. Thr'd	Spare P & T SAE-12 Ports
M33 M35	D03 Multistation Parallel Circuit Manifold with Safety Relief Valve	A & B Ports SAE-8 Str. Thr'd	Spare G Port SAE-6
M53 M55	D05 Multistation Parallel Circuit Manifold with Safety Relief Valve	A & B Ports SAE-8 Str. Thr'd	Spare G Port SAE-6

Manifolds are mounted vertically. Bottom station is number 1.

= Omit if not required





# Power Units

## V-Pak Model Ordering Code

continued on next page



**Directional Control Valve**



**\*Manapak Control Valves**



**Options and Accessories**

Code	Directional Control Valve Model Number	NFPA Mounting Pad	Nominal Flow GPM (LPM)	Description	Circuit Symbol
B	D1VW001CN***	D03	7 (26.5)	Double (Spr. Ctr)	
C	D1VW004CN***	D03	7 (26.5)	Double (Spr. Ctr)	
F	D3W1CN**	D05	20 (75.7)	Double (Spr. Ctr)	
G	D3W4CN**	D05	15 (56.8)	Double (Spr. Ctr)	

Units less valves will be supplied with station cover plates installed.

Code	Manapak Control Valves Function	Valve Model Number	NFPA Mounting Pad	Nominal Flow GPM (LPM)	Circuit Symbol
1	Flow Control	FM2DDKN	D03	7 (26.5)	
2	Flow Control	FM3DDKN	D05	12 (45.4)	
3	Pilot Operator Check	CPOM2DDN	D03	7 (26.5)	
4	Pilot Operator Check	CPOM3DDN	D05	12 (45.4)	

\*Manapak valves mounted in order of callout.

First valve will be nearest DCV; last valve will be on manifold.

Code	Options and Accessories		
	Function	Model Number	Technical Data
A*	Pump Case Heat Exchanger	RM-08-4-2	Air/Oil: 0.7 HP (0.52 kW), Rej. @ .5 GPM (1.9 LPM) 2-15 HP (1.5 - 11.2 kW) Motors
B1*	Return Heat Exchanger	RM-08-1-2	Air/Oil: 0.7 HP (0.52 kW), Rej. @ 7 GPM (26.5 LPM) 2-5 HP (1.5 - 3.7 kW) Motors only
B2*	Return Heat Exchanger	RM 190-1-2	Air/Oil: 1.5 HP (1.1 kW), Rej. @ 7 GPM (26.5 LPM) 7.5-15 HP (5.6 - 11.2 kW) Motors only
H	Pressure Filter	15P110QXRS	Microglass II Element, Vis. Ind. - 50 PSI (3.49 bar) Bypass - 4 PSI (0.27 bar), Diff. @ 7 GPM (26.5 LPM)
K	Check Valve Pump Outlet	"DT" & "C" Series	5 PSI (0.34 bar) Cracking Pressure 25 PSI (1.72 bar) Diff. @ 15 GPM (56.8 LPM)
L	Bypass Check (on Heat Exch)	C1220S65	(65 PSI) 4.5 bar Cracking Pressure
N	Return Filter	40CN110B	Microglass II Element, Visual 25 PSI (1.72 bar) Indicator 3 PSI (0.21 bar) Diff. @ 7 GPM (26.5 LPM)
O	Return Filter	12AT10C 12 GPM (45 LPM)	Cellulose Element, Ind. Gage - 15 PSI (1.03 bar) Bypass
R1	Combination Float/Temp. Switch N.O. Float Up	876782-01	Fixed Temp at 65°C (149°F) Close @ Low Level and/or 65°C (149°F) (N.O.)
R2	Combination Float/Temp. Switch Float Up	876782-02	Fixed Temp at 65°C (149°F) Open @ Low Level and/or 65°C (149°F) (N.C.)

\*Heat rejection based on flow given with a 40°F differential between transfer medium.

= Omit if not required

# Power Units

## V-Pak Model Ordering Code

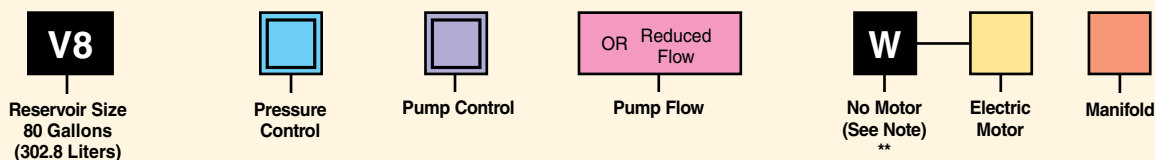

Code	Pressure Control
Omit	Single Pressure Remote Compensator
B	Single Pressure Remote Compensator with Low Pressure Standby
BJ	Single Pressure Remote Compensator with Low Pressure Standby, 24 VDC
C	Bi-Pressure Remote Compensator
CJ	Bi-Pressure Remote Compensator, 24VDC
D	Bi-Pressure Remote Compensator with Low Pressure Standby
DJ	Bi-Pressure Remote Compensator with Low Pressure Standby, 24VDC
F	Provision for Customer Supplied Remote Control Relief Valve

Code	Pump Control
Omit	Std. Remote Compensator
A*	Load Sense Flow Control

\*Unless otherwise specified, a SAE-6 37° flared port will be supplied for customer connection.

\*\*Consult factory for horsepower and hi-lo pump control options. Lead time is four weeks.

Code	Pump Flow Rate @ 1800 RPM	Pump Used and Description
15	15.6 GPM (59 LPM)	PVP33 - Std. Remote Compensator
23	23.0 GPM (87 LPM)	PVP48 - Std. Remote Compensator
36	36.1 GPM (137 LPM)	PVP76 - Std. Remote Compensator
*	Specify in GPM	Destroked (Reduced) Flow

\*Unless otherwise specified, units are shipped at max. flow rate (GPM) at 1800 RPM.

When reduced flow setting is required,

Reduced flows from 22.5 to 8.0 GPM (85.2 to 30.3 LPM), specify in 0.5 GPM increments.

Reduced flows from 35.0 to 24.0 GPM (132.5 to 90.8 LPM), specify in 1.0 GPM (3.8 LPM) increments.

Example: V\*9.5\*-- = PVP33 Pump destroked to 9.5 GPM (36.0 LPM)  
 V\*A31\*-- = PVP76 Load Sense Pump destroked to 31.0 GPM (117.3 LPM)

### NOTE:

- Manifolds are mounted vertically. Bottom station is number 1.
- M5-3 and 5 station available. M8-2 station available.

Code	Electric Motor Description HP (kW) - RPM - Frame - Type
M	7.5 (5.6) - 1800 - 213TC - TEFC
N	10 (7.5) - 1800 - 215TC - TEFC
P	15 (11.2) - 1800 - 254TC - TEFC
S	20 (14.9) - 1800 - 256TC - TEFC
Q	25 (18.6) - 1800 - 284TC - TEFC
R	30 (22.4) - 1800 - 286T - TEFC
V	40 (29.8) - 1800 - 324T - TEFC

Electric motors are 230/460V, 60 Hz 3PH. Consult factory for other motor speeds (RPM) and voltages.

\*\*Use W prefix when no motor is required on unit. When ordering, W must be followed by motor model code equivalent to frame size of motor to be used.

Example: V815WM\*\*\* = 302.8 L (80 gal) reservoir, std PVP33 unit to accept a 7.5 HP (5.6KW)/213TC C-face frame motor.

Code	Porting Block/Subplate or Manifold Type	Supply/Return Port or Actuator Port Size	Other
O	Pressure and Return Port Block with Safety Relief Valve	P Port SAE-16 T Port SAE-20	None
S5	D05 Single Station Subplate with Safety Relief Valve	A & B Ports SAE-10 Str. Thr'd	None
M5* <sup>(2)</sup>	D05 Multistation Parallel Circuit Manifold with Safety Relief and Pump Compensator Valves	A & B Ports SAE-8 Str. Thr'd	None
M82 <sup>(3)</sup>	D08 Two Parallel Circuit Manifold with Safety Relief and Pump Compensator Valves	A & B Ports SAE-16 Str. Thr'd	Y Port SAE-8 Str. Thr'd

\*When ordering Multi-Station Manifolds, the number of stations must be specified. If valves are to be mounted, specify the valves and sequence, if the model code exceeds 25 digits, call factory.

Example: V815QM53BCB1  
 3 Station D05 Manifold  
 Station #1: B  
 Station #2: C  
 Station #3: B1

Example: V815QM55B1B1CBC  
 5-Station D05 Manifold  
 Station #1: B1  
 Station #2: B1  
 Station #3: C  
 Station #4: B  
 Station #5: C

= Omit if not required



# Power Units

## V-Pak Model Ordering Code



Directional Control Valve



\*Manapak Control Valves



Options and Accessories

Code	Directional Control Valve Model Number	NFPA Mounting Pad	Nominal Flow GPM (LPM)	Description	Circuit Symbol
B	D1VW001CN***	D03	7 (26.5)	Double (Spr. Ctr)	
C	D1VW004CN***	D03	7 (26.5)	Double (Spr. Ctr)	

Code	Manapak Control Valves Function	Valve Model Number	NFPA Mounting Pad	Nominal Flow GPM (LPM)	Circuit Symbol
1	Flow Control	FM2DDKN	D03	7 (26.5)	
3	Pilot Operator Check	CPOM2DDN	D03	7 (26.5)	

\*Manapak valves mounted in order of callout.  
First valve will be nearest DCV; last valve will be on manifold.

Code	Options and Accessories		
	Function	Model Number	Technical Data
A*	Continuous Pump Case Cooling	RM-08-2-2	Air/Oil: Max. Oil Flow 4.5 GPM (17 LPM), 0.8 HP (0.6 kW) Heat Rejection
B*	Continuous Pump Case Cooling	RM-19-2-2	Air/Oil: Max. Oil Flow 4.5 GPM (17 LPM) 1.5 HP (1.1 kW) Heat Rejection
C*	Filter/Cooling Loop	ACC-22-2-1PH 40CN205Q	Air Oil w/1 PH Motor: Oil Flow 4.5 GPM (17 LPM), 4.5 HP (3.3 kW) Heat Rejection
H	Pressure Filter	P210QM250NN1	10 Micron Microglass II Dual Element, Mechanical Indicator
K	Check Valve Pump Outlet	493-16-D1-2	5 PSI (0.3 bar) Cracking Pressure
L	Bypass Check	C2020S65	65 PSI (4.6 bar) Cracking Pressure
N	Return Filter	40CN210Q	10 Micron Microglass II Dual Element, Mechanical Indicator** (8 PSID)
QS	Return Filter	80CN110QE2GS24-4	10 Micron Microglass II Single Element Electrical Indicator (25 PSI)
R1	Combination Float/Temp. Switch N.O. Float Up	877501	Fixed Temp at 65°C (149°F) Close @ Low Level and/or 65°C (149°F) (N.O.)
R2	Combination Float/Temp. Switch N.C. Float Up	877502	Fixed Temp at 65°C (149°F) Open @ Low Level and/or 65°C (149°F) (N.C.)

\*Heat rejection data is based on 100 SSU oil leaving the cooler 22°C (72°F) higher than the ambient air temperature used for cooling.

Option A available from 7.5 HP (0.6 kW) thru 25 HP (18.5 kW).

Option C not available with option A or B.

\*\*Based on max. 36 GPM (136 LPM) w/150 SUS oil.

= Omit if not required



# Reference

*Page*

**(M)** = Mobile **(I)** = Industrial **(B)** = Mobile & Industrial

<b>SAE Flanges and Shafts</b>	<b>155</b>
<b>Formulas &amp; Conversions</b>	<b>156</b>
<b>Offer of Sale</b>	<b>157</b>



ENGINEERING YOUR SUCCESS.

# SAE Flanges & Shafts

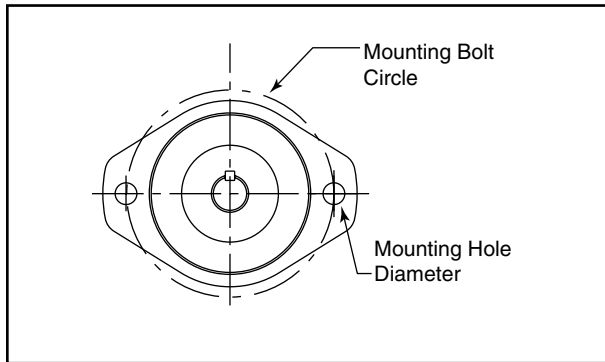

**NFPA Standard  
Two-Bolt Pump/Motor Mounting Flanges**

Flange Code	SAE No.	SAE hp Rating <sup>1</sup>	Mtg. Bolt Circle	Mtg. Hole Dia.	Pilot Dia.	Pilot Ht.
50-2	N/A	N/A	3/4	13/32	1	1/4
82-2	A	10	43/16	7/16	3 1/4	1/4
101-2	B	25	5 3/4	9/16	4	3/8
127/2	C	50	7 1/8	1 1/16	5	1/2
152-2	D	100	9	1 3/16	6	1/2
165-2	E	200	12 1/2	1 1/16	6 1/2	5/8
177-2	F	300	13 25/32	1 1/16	7	5/8

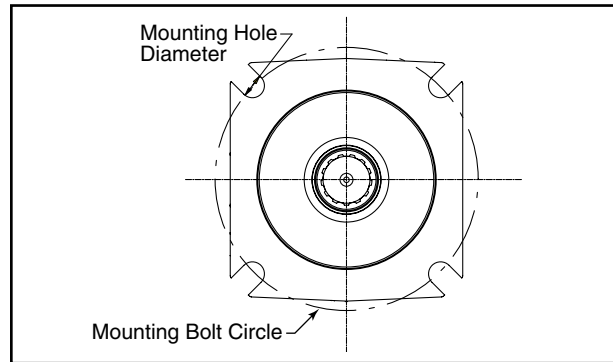

**NFPA Standard  
Four-Bolt Pump/Motor Mounting Flanges**

Flange Code	SAE No.	SAE hp Rating <sup>1</sup>	Mtg. Bolt Circle	Mtg. Hole Dia.	Pilot Dia.	Pilot Ht.
101-4	B	25	5	9/16	4	3/8
127-4	C	50	6 3/8	1 1/16	5	1/2
152-4	D	100	9	1 3/16	6	1/2
165-4	E	200	12 1/2	1 1/16	6 1/2	5/8
177-4	F	300	13 25/32	1 1/16	7	5/8

<sup>1</sup> 1750 rpm electric motor

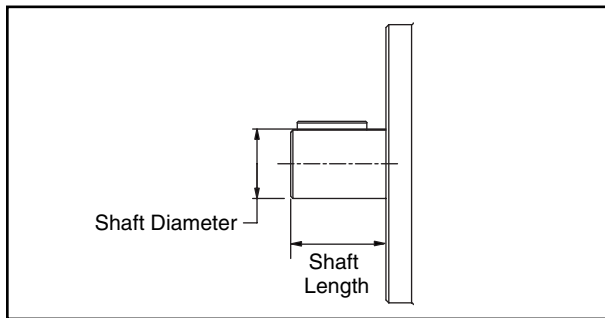

**NFPA Standard  
Straight Shafts without Thread**

Shaft Code	SAE Ref. <sup>2</sup>	Shaft Dia.	Short Shaft Length	Long Shaft Length	Key Width
13-1	N/A	1/2	3/4	N/A	1/8
16-1	A	5/8	1 5/16	2	5/32
22-1	B	7/8	1 5/16	2 1/2	1/4
25-1	B-B	1	1 1/2	2 3/4	1/4
32-1	C	1 1/4	1 7/8	3	5/16
38-1	C-C	1 1/2	2 1/8	3 1/4	3/8
44-1	D, E	1 3/4	2 5/8	3 5/8	7/16

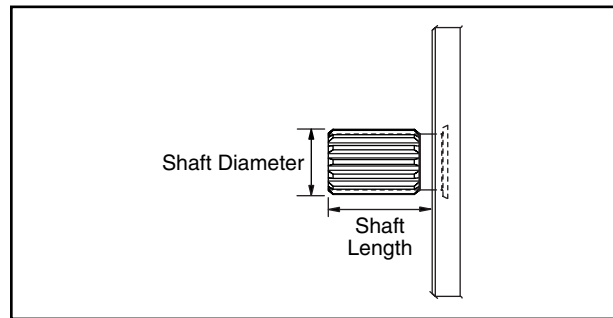

**NFPA Standard  
30° Involute Spline Shafts**

Shaft Code	SAE Ref. <sup>2</sup>	Shaft Dia.	Shaft Length	Spline Specifications
13-4	N/A	1/2	3/4	9T, 20/40 DP
16-4	A	5/8	1 5/16	9T, 16/32 DP
22-4	B	7/8	1 5/16	13T, 16/32 DP
25-4	B-B	1	1 1/2	15T, 16/32 DP
32-4	C	1 1/4	1 7/8	14T, 12/24 DP
38-4	C-C	1 1/2	2 1/8	17T, 12/24 DP
44-4	D, E	1 3/4	2 5/8	13T, 8/16 DP
50-4	N/A	2	3 1/8	15T, 8/16 DP

<sup>2</sup> Indicates matching SAE front flange for each shaft diameter.



# Formulas & Conversions

## Formulas

PRESSURE (psi)	=	$\frac{\text{FORCE (pounds)}}{\text{UNIT AREA (square inches)}}$	CYLINDER AREA (in <sup>2</sup> )	=	$\pi \times \text{RADIUS}^2 \text{ (inches)}$
FLOW RATE (gpm)	=	$\frac{\text{VOLUME (gallons)}}{\text{UNIT TIME (minutes)}}$		=	$\frac{\pi}{4} \times \text{DIAMETER}^2 \text{ (inches)}$
HORSEPOWER (hp)	=	$\frac{\text{PRESSURE (psig)} \times \text{FLOW (gpm)}}{1714}$	CYLINDER FORCE (lbs)	=	PRESSURE (psig) × NET AREA (in <sup>2</sup> )
VELOCITY	=	$\frac{0.3208 \times \text{FLOW RATE THROUGH I.D. (gpm)}}{\text{INTERNAL AREA (square inches)}}$	CYLINDER VELOCITY (ft/sec)	=	$\frac{231 \times \text{FLOW RATE (gpm)}}{12 \times 60 \times \text{NET AREA (in}^2\text{)}}$
SPECIFIC GRAVITY	=	$\frac{\text{WEIGHT OF ONE CUBIC FOOT OF FLUID}}{\text{WEIGHT OF ONE CUBIC FOOT OF WATER}}$	CYLINDER VOLUME	=	$\frac{\pi \times \text{RADIUS}^2 \text{ (in)} \times \text{STROKE (in)}}{231}$
FLOW (gpm)	=	$\frac{\text{RPM} \times \text{PUMP DISPLACEMENT (in}^3\text{/rev)}}{231}$	CYLINDER FLOW RATE (gpm)	=	$\frac{12 \times 60 \times \text{VELOCITY (ft/sec)} \times \text{NET AREA (in}^2\text{)}}{231}$
HORSEPOWER INPUT	=	$\frac{\text{FLOW RATE OUTPUT (gpm)} \times \text{PRESSURE (psig)}}{1714 \times \text{EFFICIENCY}}$	TORQUE (in-lbs)	=	$\frac{\text{PRESSURE (psig)} \times \text{F.M. DISPLACEMENT (in}^3\text{/rev)}}{2\pi}$
OVERALL EFFICIENCY (%)	=	$\frac{\text{OUTPUT HORSEPOWER}}{\text{INPUT HORSEPOWER}} \times 100$		=	$\frac{\text{HORSEPOWER} \times 63025}{\text{RPM}}$
OVERALL EFFICIENCY (%)	=	VOLUMETRIC EFF. × MECHANICAL EFF.		=	$\frac{\text{FLOW RATE (gpm)} \times \text{PRESSURE (psig)} \times 36.77}{\text{RPM}}$
VOLUMETRIC EFFICIENCY (%)	=	$\frac{\text{ACTUAL FLOW RATE OUTPUT (gpm)}}{\text{THEORETICAL FLOW RATE OUTPUT (gpm)}} \times 100$	TORQUE/100 psig (in-lbs)	=	$\frac{\text{F.M. DISPLACEMENT (in}^3\text{/rev)}}{0.0628}$
MECHANICAL EFFICIENCY (%)	=	ACTUAL TORQUE TO DRIVE	SPEED (RPM)	=	$\frac{231 \times \text{FLOW RATE (gpm)}}{\text{F.M. DISPLACEMENT (in}^3\text{/rev)}}$
B <sub>10</sub> BEARING LIFE (hr)	=	$\frac{\text{RATED LIFE}}{(\text{hr})} \times \frac{\text{RATED SPEED (rpm)}}{\text{NEW SPEED (rpm)}} \times \left( \frac{\text{RATED PRESSURE (psig)}}{\text{NEW PRESSURE (psig)}} \right)^3$	MOTOR HORSEPOWER (hp)	=	$\frac{\text{TORQUE OUTPUT (in-lbs)} \times \text{RPM}}{63025}$
DISPLACEMENT (civ)	=	$\frac{\text{FLOW RATE (gpm)} \times 231}{\text{PUMP RPM}}$	TORQUE (in-lbs)	=	LEVER LENGTH (inch) × PULL (lbs)
TORQUE (in-lbs)	=	$\frac{\text{HORSEPOWER} \times 63025}{\text{RPM}}$	PISTON AREA (in <sup>2</sup> )	=	ID <sup>2</sup> × 0.7854
TORQUE (in-lbs)	=	$\frac{\text{PRESSURE (psig)} \times \text{PUMP DISPLACEMENT (in}^3\text{/rev)}}{2\pi}$	VELOCITY	=	$\frac{0.3208 \times \text{FLOW (gpm)}}{\text{AREA OF PASSAGE (in}^2\text{)}}$

## The Universal Gas Law

$$P_1 V_1 T_2 = P_2 V_2 T_1$$

## Common Conversions

To Convert	Into	Multiply by	To Convert	Into	Multiply by
BAR	PSI	14.5	PSI	BAR	0.06896
cc	in <sup>3</sup>	0.06102	in <sup>3</sup>	cc	16.39
°C	°F	(°C × 9/5) + 32	°F	°C	(°F - 32) / 1.8
KG	lbs	2.205	lbs	Kg	0.4535
KW	HP	1.341	HP	KW	0.7457
liters	gallons	0.2642	gallons	liters	3.785
mm	inches	0.03937	inch	mm	25.4
Nm	lb-ft	0.7375	lb-ft	Nm	1.356

## Electric Motors

INPUT HP TO ELEC. MOTOR	=	$\frac{\text{PUMP INPUT HP}}{\text{ELECTRIC MOTOR EFFICIENCY}}$
WATTS	=	ELECTRIC MOTOR INPUT HP × 746

$E = I \times R$       POWER (W) = I × E      POWER (W) = I<sup>2</sup> × E  
 where: E = VOLTAGE    I = CURRENT    R = RESISTANCE    W = WATTS

SERIES	PARALLEL
E Total = E <sub>r1</sub> = E <sub>r2</sub> = E <sub>r3</sub>	E Total = E <sub>r1</sub> + E <sub>r2</sub> = E <sub>r3</sub>
I Total = I <sub>r1</sub> = I <sub>r2</sub> = I <sub>r3</sub>	I Total = I <sub>r1</sub> + I <sub>r2</sub> + I <sub>r3</sub>
R Total = R <sub>1</sub> + R <sub>2</sub> + R <sub>3</sub>	R Total = $\frac{1}{\frac{1}{R_1} + \frac{1}{R_2} + \frac{1}{R_3}}$

## Thermal Formulas

NOTE: ONE BRITISH THERMAL UNIT (BTU) IS THE AMOUNT OF HEAT REQUIRED TO RAISE THE TEMPERATURE OF ONE POUND OF WATER 1° FAHRENHEIT. ONE HORSEPOWER = 2545 BTU/HR.		
RESERVOIR COOLING CAPACITY BASED ON ADEQUATE AIR CIRCULATION	HEAT (BTU/HR) = 2 × TEMPERATURE DIFFERENCE BETWEEN RESERVOIR WALLS AND AIR (°F) × AREA OF RESERVOIR (sq. ft.)	BTU/HR = 2.0 × πT × A
HEAT IN HYDRAULIC OIL (approx.) DUE TO SYSTEM INEFFICIENCY (SG = 0.89 - 0.92)	HEAT (BTU/HR) = FLOW RATE (gpm) × 210 × TEMPERATURE DIFFERENCE (°F)	BTU/HR = Q × 210 × πT

# Offer of Sale



The items described in this document and other documents and descriptions provided by Parker Hannifin Corporation, Hydraulics Group, and its authorized distributors ("Seller") are hereby offered for sale at prices to be established by Seller. This offer and its acceptance by any customer ("Buyer") shall be governed by all of the following Terms and Conditions. Buyer's order for any item described in its document, when communicated to Seller verbally, or in writing, shall constitute acceptance of this offer. All goods or work described will be referred to as "Products".

**1. Terms and Conditions.** Seller's willingness to offer Products, or accept an order for Products, to or from Buyer is expressly conditioned on Buyer's assent to these Terms and Conditions and to the terms and conditions found on-line at [www.parker.com/saleterms/](http://www.parker.com/saleterms/). Seller objects to any contrary or additional term or condition of Buyer's order or any other document issued by Buyer.

**2. Price Adjustments; Payments.** Prices stated on the reverse side or preceding pages of this document are valid for 30 days. After 30 days, Seller may change prices to reflect any increase in its costs resulting from state, federal or local legislation, price increases from its suppliers, or any change in the rate, charge, or classification of any carrier. The prices stated on the reverse or preceding pages of this document do not include any sales, use, or other taxes unless so stated specifically. Unless otherwise specified by Seller, all prices are F.O.B. Seller's facility, and payment is due 30 days from the date of invoice. After 30 days, Buyer shall pay interest on any unpaid invoices at the rate of 1.5% per month or the maximum allowable rate under applicable law.

**3. Delivery Dates; Title and Risk; Shipment.** All delivery dates are approximate and Seller shall not be responsible for any damages resulting from any delay. Regardless of the manner of shipment, title to any products and risk of loss or damage shall pass to Buyer upon tender to the carrier at Seller's facility (i.e., when it's on the truck, it's yours). Unless otherwise stated, Seller may exercise its judgment in choosing the carrier and means of delivery. No deferral of shipment at Buyer's request beyond the respective dates indicated will be made except on terms that will indemnify, defend and hold Seller harmless against all loss and additional expense. Buyer shall be responsible for any additional shipping charges incurred by Seller due to Buyer's changes in shipping, product specifications or in accordance with Section 13, herein.

**4. Warranty.** Seller warrants that the Products sold hereunder shall be free from defects in material or workmanship for a period of eighteen months from the date of delivery to Buyer. The prices charged for Seller's products are based upon the exclusive limited warranty stated above, and upon the following disclaimer: **DISCLAIMER OF WARRANTY: THIS WARRANTY COMPRISES THE SOLE AND ENTIRE WARRANTY PERTAINING TO PRODUCTS PROVIDED HEREUNDER. SELLER DISCLAIMS ALL OTHER WARRANTIES, EXPRESS AND IMPLIED, INCLUDING MERCHANTABILITY AND FITNESS FOR A PARTICULAR PURPOSE.**

**5. Claims; Commencement of Actions.** Buyer shall promptly inspect all Products upon delivery. No claims for shortages will be allowed unless reported to the Seller within 10 days of delivery. No other claims against Seller will be allowed unless asserted in writing within 60 days after delivery or, in the case of an alleged breach of warranty, within 30 days after the date within the warranty period on which the defect is or should have been discovered by Buyer. Any action based upon breach of this agreement or upon any other claim arising out of this sale (other than an action by Seller for any amount due to Seller from Buyer) must be commenced within thirteen months from the date of tender of delivery by Seller or, for a cause of action based upon an alleged breach of warranty, within thirteen months from the date within the warranty period on which the defect is or should have been discovered by Buyer.

**6. LIMITATION OF LIABILITY.** UPON NOTIFICATION, SELLER WILL, AT ITS OPTION, REPAIR OR REPLACE A DEFECTIVE PRODUCT, OR REFUND THE PURCHASE PRICE. IN NO EVENT SHALL SELLER BE LIABLE TO BUYER FOR ANY SPECIAL, INDIRECT, INCIDENTAL OR CONSEQUENTIAL DAMAGES ARISING OUT OF, OR AS THE RESULT OF, THE SALE, DELIVERY, NON-DELIVERY, SERVICING, USE OR LOSS OF USE OF THE PRODUCTS OR ANY PART THEREOF, OR FOR ANY CHARGES OR EXPENSES OF ANY NATURE INCURRED WITHOUT SELLER'S WRITTEN CONSENT, EVEN IF SELLER HAS BEEN NEGLIGENT, WHETHER IN CONTRACT, TORT OR OTHER LEGAL THEORY. IN NO EVENT SHALL SELLER'S LIABILITY UNDER ANY CLAIM MADE BY BUYER EXCEED THE PURCHASE PRICE OF THE PRODUCTS.

**7. Contingencies.** Seller shall not be liable for any default or delay in performance if caused by circumstances beyond the reasonable control of Seller.

**8. User Responsibility.** The user, through its own analysis and testing, is solely responsible for making the final selection of the system and Product and assuring that all performance, endurance, maintenance, safety and warning requirements of the application are met. The user must analyze all aspects of the application and follow applicable industry standards and Product information. If Seller provides Product or system options, the user is responsible for determining that such data and specifications are suitable and sufficient for all applications and reasonably foreseeable uses of the Products or systems.

**9. Loss to Buyer's Property.** Any designs, tools, patterns, materials, drawings, confidential information or equipment furnished by Buyer or any other items which become Buyer's property, may be considered obsolete and may be destroyed by Seller after two consecutive years have elapsed without Buyer placing an order for the items which are manufactured using such property. Seller shall not be responsible for any loss or damage to such property while it is in Seller's possession or control.

**10. Special Tooling.** A tooling charge may be imposed for any special tooling, including without limitation, dies, fixtures, molds and patterns, acquired to manufacture Products. Such special tooling shall be and remain Seller's property notwithstanding payment of any charges by Buyer. In no event will Buyer acquire any interest in apparatus belonging to Seller which is utilized in the manufacture of the Products, even if such apparatus has been specially converted or adapted for such manufacture and notwithstanding any charges paid by Buyer. Unless otherwise agreed, Seller shall have the right to alter, discard or otherwise dispose of any special tooling or other property in its sole discretion at any time.

**11. Buyer's Obligation; Rights of Seller.** To secure payment of all sums due or otherwise, Seller shall retain a security interest in the goods delivered and this agreement shall be deemed a Security Agreement under the Uniform Commercial Code. Buyer authorizes Seller as its attorney to execute and file on Buyer's behalf all documents Seller deems necessary to perfect its security interest. Seller shall have a security interest in, and lien upon, any property of Buyer in Seller's possession as security for the payment of any amounts owed to Seller by Buyer.

**12. Improper Use and Indemnity.** Buyer shall indemnify, defend, and hold Seller harmless from any claim, liability, damages, lawsuits, and costs (including attorney fees), whether for personal injury, property damage, patent, trademark or copyright infringement or any other claim, brought by or incurred by Buyer, Buyer's employees, or any other person, arising out of: (a) improper selection, improper application or other misuse of Products purchased by Buyer from Seller; (b) any act or omission, negligent or otherwise, of Buyer; (c) Seller's use of patterns, plans, drawings, or specifications furnished by Buyer to manufacture Product; or (d) Buyer's failure to comply with these terms and conditions. Seller shall not indemnify Buyer under any circumstance except as otherwise provided.

**13. Cancellations and Changes.** Orders shall not be subject to cancellation or change by Buyer for any reason, except with Seller's written consent and upon terms that will indemnify, defend and hold Seller harmless against all direct, incidental and consequential loss or damage. Seller may change product features, specifications, designs and availability with notice to Buyer.

**14. Limitation on Assignment.** Buyer may not assign its rights or obligations under this agreement without the prior written consent of Seller.

**15. Entire Agreement.** This agreement contains the entire agreement between the Buyer and Seller and constitutes the final, complete and exclusive expression of the terms of the agreement. All prior or contemporaneous written or oral agreements or negotiations with respect to the subject matter are herein merged.

**16. Waiver and Severability.** Failure to enforce any provision of this agreement will not waive that provision nor will any such failure prejudice Seller's right to enforce that provision in the future. Invalidation of any provision of this agreement by legislation or other rule of law shall not invalidate any other provision herein. The remaining provisions of this agreement will remain in full force and effect.

**17. Termination.** This agreement may be terminated by Seller for any reason and at any time by giving Buyer thirty (30) days written notice of termination. In addition, Seller may by written notice immediately terminate this agreement for the following: (a) Buyer commits a breach of any provision of this agreement (b) the appointment of a trustee, receiver or custodian for all or any part of Buyer's property (c) the filing of a petition for relief in bankruptcy of the other Party on its own behalf, or by a third party (d) an assignment for the benefit of creditors, or (e) the dissolution or liquidation of the Buyer.

**18. Governing Law.** This agreement and the sale and delivery of all Products hereunder shall be deemed to have taken place in and shall be governed and construed in accordance with the laws of the State of Ohio, as applicable to contracts executed and wholly performed therein and without regard to conflicts of laws principles. Buyer irrevocably agrees and consents to the exclusive jurisdiction and venue of the courts of Cuyahoga County, Ohio with respect to any dispute, controversy or claim arising out of or relating to this agreement. Disputes between the parties shall not be settled by arbitration unless, after a dispute has arisen, both parties expressly agree in writing to arbitrate the dispute.

**19. Indemnity for Infringement of Intellectual Property Rights.** Seller shall have no liability for infringement of any patents, trademarks, copyrights, trade dress, trade secrets or similar rights except as provided in this Section. Seller will defend and indemnify Buyer against allegations of infringement of U.S. patents, U.S. trademarks, copyrights, trade dress and trade secrets ("Intellectual Property Rights"). Seller will defend at its expense and will pay the cost of any settlement or damages awarded in an action brought against Buyer based on an allegation that a Product sold pursuant to this Agreement infringes the Intellectual Property Rights of a third party. Seller's obligation to defend and indemnify Buyer is contingent on Buyer notifying Seller within ten (10) days after Buyer becomes aware of such allegations of infringement, and Seller having sole control over the defense of any allegations or actions including all negotiations for settlement or compromise. If a Product is subject to a claim that it infringes the Intellectual Property Rights of a third party, Seller may, at its sole expense and option, procure for Buyer the right to continue using the Product, replace or modify the Product so as to make it noninfringing, or offer to accept return of the Product and return the purchase price less a reasonable allowance for depreciation. Notwithstanding the foregoing, Seller shall have no liability for claims of infringement based on information provided by Buyer, or directed to Products delivered hereunder for which the designs are specified in whole or part by Buyer, or infringements resulting from the modification, combination or use in a system of any Product sold hereunder. The foregoing provisions of this Section shall constitute Seller's sole and exclusive liability and Buyer's sole and exclusive remedy for infringement of Intellectual Property Rights.

**20. Taxes.** Unless otherwise indicated, all prices and charges are exclusive of excise, sales, use, property, occupational or like taxes which may be imposed by any taxing authority upon the manufacture, sale or delivery of Products.

**21. Equal Opportunity Clause.** For the performance of government contracts and where dollar value of the Products exceed \$10,000, the equal employment opportunity clauses in Executive Order 11246, VEVRAA, and 41 C.F.R. §§ 60-1.4(a), 60-741.5(a), and 60-250.4, are hereby incorporated.



## System Requirements

To view the DVD, the following are required:

- **Pentium® 3-class processor**
- **Win 2000, Win XP, Win Vista or Win 7**
- **32 MB of RAM**
- **1 GB of available hard-disk space**
- **DVD player**

## Acrobat Reader

Catalog files are viewed using Adobe Acrobat Reader. If you do not have Acrobat Reader installed on your PC, Win Vista, Win 7 and most Win XP systems will give you an web install option for Acrobat Reader on the bottom of the DVD install menu.

*You must have Acrobat 6.0 or higher to take advantage of the search feature described in the next section.*

## To View the DVD

The DVD is self-loading. Just place it in your DVD drive. Acrobat Reader will open (or install), and the opening page will appear on your monitor. From this page you can navigate to the following sections.

- **Search\* takes you to the search feature. When the search window opens, type a word(s) or code\* and press enter. A list of pages where that word appears is shown. Select one and click the View button. Repeat as needed.**
- **Product Information or Contents takes you to the selection of catalogs and products on the DVD.**
- **Product Overview takes you to a .pdf file of this Hydraulic Pump Division Product Range.**

- **Warning/Offer of Sale takes you to these legal documents.**
- **Getting Started provides a summary of how to navigate using Acrobat Reader.**
- **Contact Us provides you with phone, fax and online information.**

Text links are easily identified by blue type. The catalog files are fully bookmarked to make navigation quick and easy. Each catalog also has a bookmark which will take you to the Parker web home page *if you are online while you are viewing the DVD.*

Adobe and Acrobat are registered trademarks of Adobe Systems Inc.

Windows is a registered trademark of Microsoft Corp.



Parker Hannifin Corporation  
**Hydraulics Pump Division**  
14249 Industrial Parkway  
Marysville, OH 43040  
Tel: 937-644-4532  
Fax: 937-642-3639  
[www.phpump.com](http://www.phpump.com)

